

Holman

Instruction Guide 31270 – 31280 – 31300

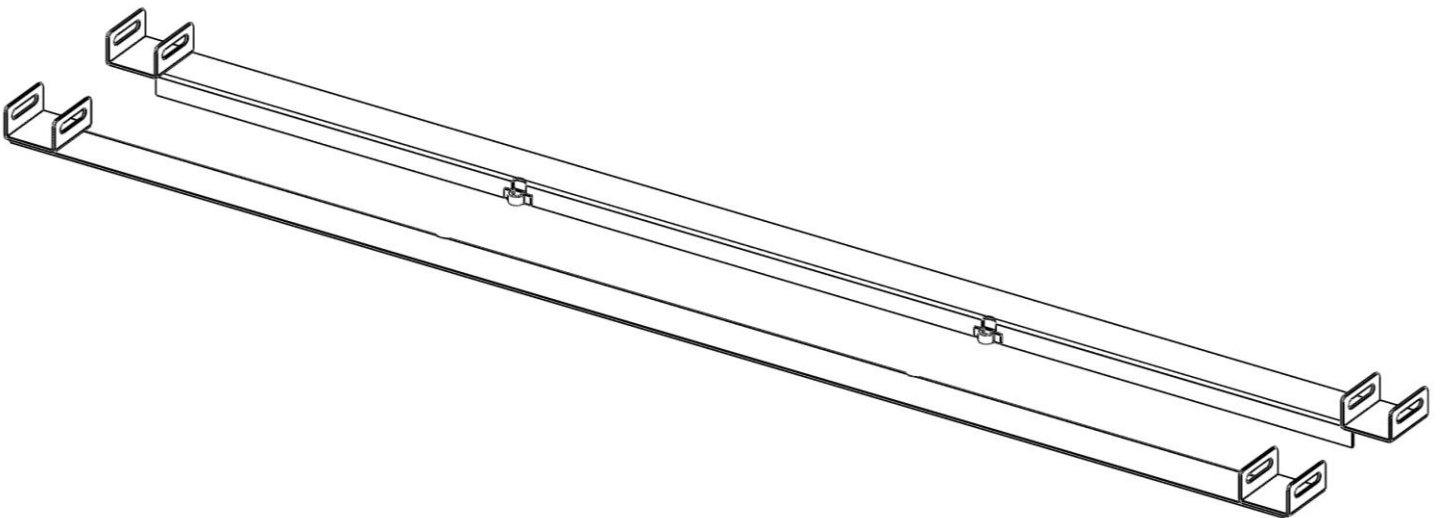

Holman
Rancho Cordova, CA 95742
800-343-7486
InstallationSupport@Holman.com

PLEASE READ ALL INSTRUCTIONS AND WARNINGS PRIOR TO ASSEMBLING, INSTALLING, AND USING THIS PRODUCT.

Warning



Always check for wires, fuel tanks and lines, brake lines and other important vehicle functionality items prior to drilling and installing all products.



Too much weight will greatly reduce the stability of your vehicle. Holman makes no representation or warranty as to the amount of weight your vehicle can safely carry. For guidance, we recommend that you consult the vehicle manufacturer.

AT NO TIME SHOULD THE WEIGHT OF THE VEHICLE, RACK, DRIVER, PASSENGERS AND CARGO LOADED ON A HOLMAN RACK EXCEED EITHER THE GROSS VEHICLE WEIGHT RATIO (GVWR) OR THE GROSS AXLE WEIGHT RATIO (GAWR) AS SPECIFIED BY THE VEHICLE MANUFACTURER.



Do not use your rack with the rear cross bar removed. Removal of rear crossbar will affect structural integrity of the rack.



Secure all payloads properly for safe transportation.

Table of Contents

Before You Begin	1
Parts List.....	3
Installation Preparation.....	3
Step 1 – Install Full-length Bed Rails Using Clamps and T-nuts	3
Step 2 – Permanently Bolting Full-length Bed Rails to Factory Bed Rail.....	4
Step 3 – Attach Legs to Feet	4



Before You Begin

- Read all instructions carefully, and follow each step in proper sequence, for ease and speed in assembling your rack.
- Be sure to have your rack preassembled. These bed rails will work with 80000 and 80020 Pro III Racks.
- **PROPER SEALANT APPLICATION IS CRITICAL TO PREVENTING WATER PENETRATION INSIDE THE RACK. Apply a healthy bead of sealant entirely around every swaged joint and every bolt going through tubing. Improper sealing can lead to water penetration and rust on inside surfaces.**

DON'T OVERLOAD YOUR VEHICLE!

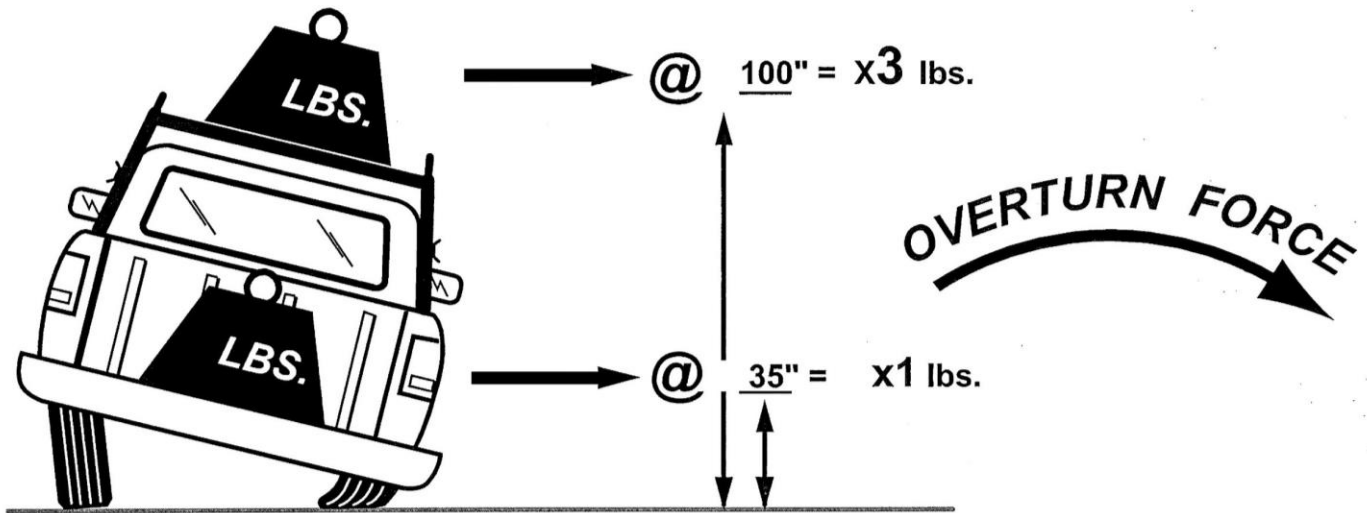

WEIGHT CARRIED ABOVE THE FLOOR OF THE TRUCK BED (E.G. ON AN OVERHEAD TRUCK RACK) WILL SIGNIFICANTLY INCREASE THE VEHICLE'S TENDENCY TO OVERTURN. ALWAYS KEEP HEAVY LOADS EVENLY DISTRIBUTED AND AS LOW AS POSSIBLE. IT IS IMPORTANT TO NOTE THAT THE HOLMAN RACK LOAD BEARING CAPACITY OF 1700 LBS. MAY BE GREATER THAN YOUR TRUCK'S GAWR OR GVWR CAPACITY, AND IS PROBABLY GREATER THAN THE WEIGHT THAT CAN BE SAFELY CARRIED OVERHEAD. RETIGHTEN ALL BOLTS AFTER FIRST USE, PERIODICALLY CHECK BOLTS FOR TIGHTNESS.

For TECHNICAL SUPPORT Call:

1.800.343.7486

or email: InstallationSupport@Holman.com

Parts List

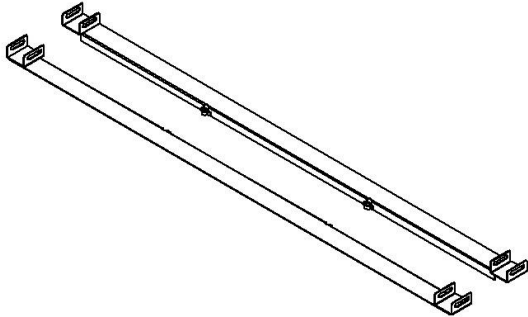
NO.	ITEM	PART NUMBER	DESCRIPTION	QTY.
1		13-00995 OR 13-00142 OR 13-10437	FULL LENGTH BED RAIL, 72" OR FULL LENGTH BED RAIL, 78" OR FULL LENGTH BED RAIL, 96"	2

Tools Needed

9/16", 3/4" Sockets and Wrench	3/4" Box Wrench
3/8" Drill Bit and Drill	7/32", 3/8" Allen Wrench

Installation Preparation

- Be sure to have your truck rack (80000 or 82000) prebuilt and follow all instructions included with your rack other than the foot mounting instructions. Discard the feet that came with your rack.

Step 1 – Install Full-length Bed Rails Using Clamps and T-nuts

- Position the full-length bed rail on the truck factory bedrail, as far forward as possible, firmly against the inside of the bed rail.
- Mark and drill a hole in the footplate that is approximately over the center of the stake pocket in the front and rear.
- Remove full-length bed rail and insert a 3/8" x 2-1/2" button head screw, a 3/8" lock nut, and 3/8" flat washer through the drilled holes into a 3/8" t-nut.

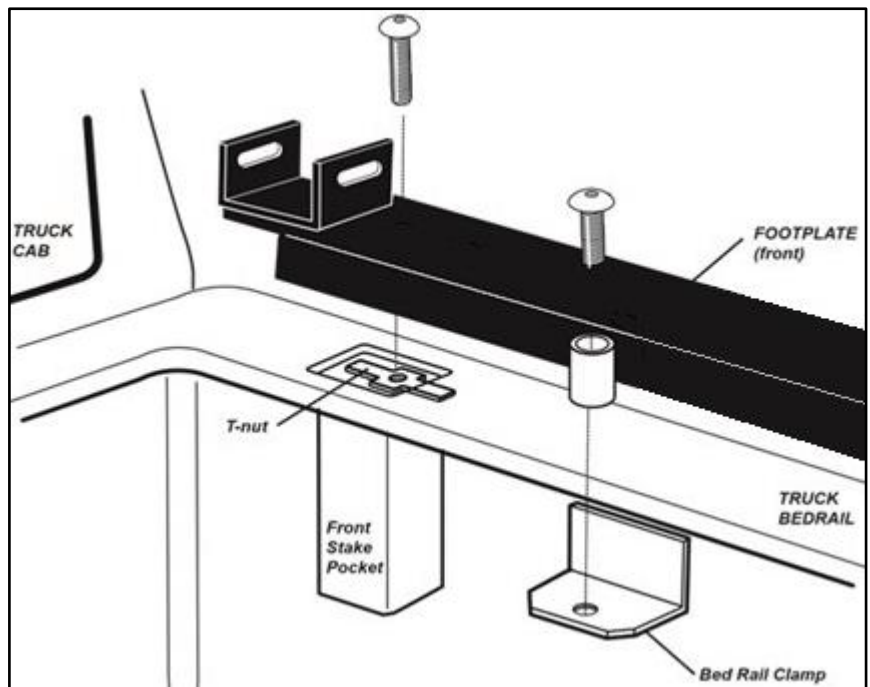

NOTE: If you are unable to use stake pocket mounting, be sure to use at least one permanent mount per corner of the rack following the instructions below. Ideally there should be at least one mount as close to each leg as possible.

- Install a 1/2" x 2-1/2" button head screw through each of the saddles and into a rail clamp.
- Repeat for opposite side.

Step 2 – Permanently Bolting Full-length Bed Rails to Factory Bed Rail

Follow these steps if you prefer to permanently mount the full-length bed rails to the factory bed rail.

- Verify the permanent mount location is accessible from inside the bed, below the factory bed rail. Different vehicles have different possible mounting locations.
- Mark and drill a hole in the full-length bed rail that is over the desired mounting locations.
- With full-length bed rail in place, mark on the factory bed rail through the hole drilled into the full-length bed rail.
- Remove full-length bed rail.
- Using a 13/32" drill bit, drill through the factory bed rail at the marked locations.
- Reinstall full-length bed rail into prior position.
- Install a 3/8" x 1-3/4" button head screw through each hole into a 3/8" washer and 3/8" lock nut at each desired mounting point.
- Repeat for opposite side.

Step 3 – Attach Legs to Feet

- **Be sure to have rack fully assembled at this point and ready to be bolted to the full-length bed rails.**
- Lift rack and set legs into slotted channels on the full-length bed rails.
- Insert 1/2" x 3-3/4" hex head bolt and 1/2" flat washer through slotted channel and leg.
- Loosely install 1/2" washer and 1/2" jam nut onto opposite end of 1/2" x 3-3/4" hex head bolt.
- Repeat for each leg.

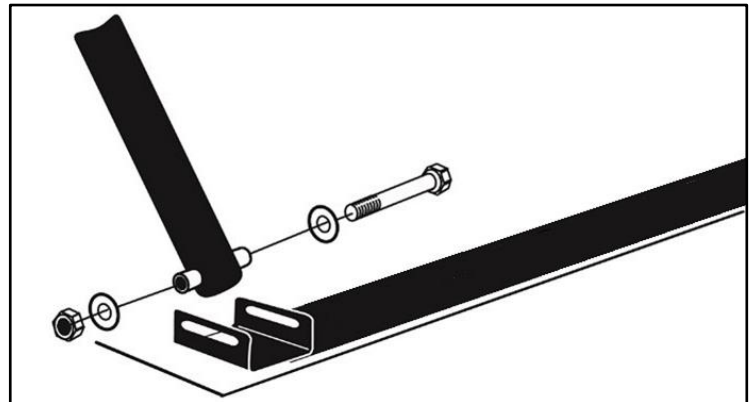

GO BACK AND TIGHTEN ALL HARDWARE.

INSTALLATION AND ASSEMBLY ARE COMPLETE.