

# Holman

---

## Installation Guide 40170

---

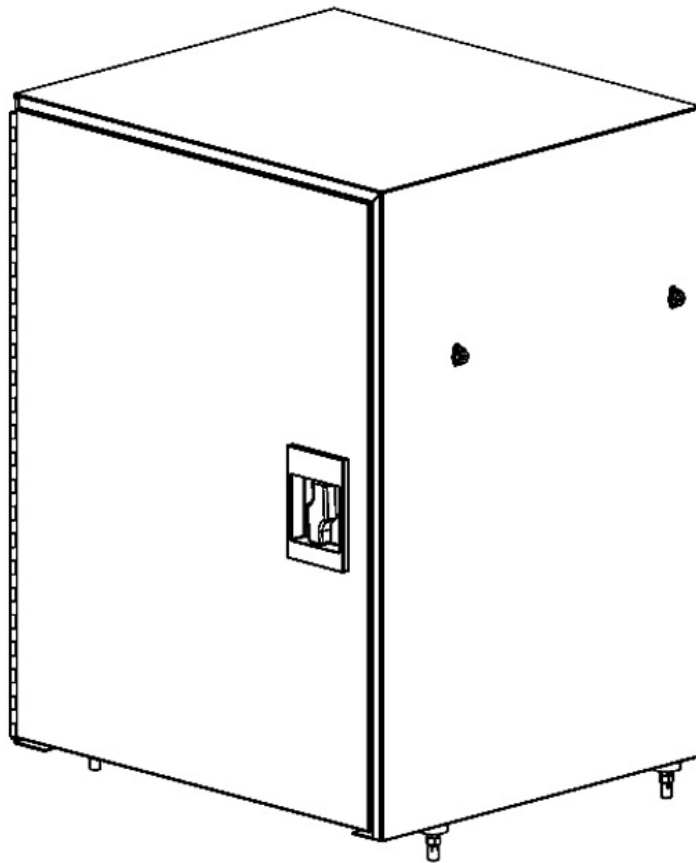

---

Holman  
Rancho Cordova, CA 95742  
800-343-7486  
[InstallationSupport@Holman.com](mailto:InstallationSupport@Holman.com)

---

---

## PLEASE READ ALL INSTRUCTIONS AND WARNINGS PRIOR TO ASSEMBLING, INSTALLING, AND USING THIS PRODUCT.

---

### Warning



Always check for wires, fuel tanks and lines, brake lines and other important vehicle functionality items prior to drilling and installing all products.

---

### Table of Contents

Tools Needed.....	1
Before You Begin.....	1
Parts List.....	2
Hardware.....	2
Step 1 – Find Mounting Location.....	3
Step 2 – Install Plus Nuts.....	3
Step 3 – Install Box.....	4

---

### Tools Needed

7/16" Socket and Wrench	Phillips Screwdriver
5/16" Drill Bit	Drill

---



### Before You Begin

- Read all instructions prior to assembling or installing any Holman product.
- **Always locate your installation locations prior to performing any work.**
- **ENSURE SAFETY WHILE INSTALLING OR DRILLING INTO VEHICLE.**

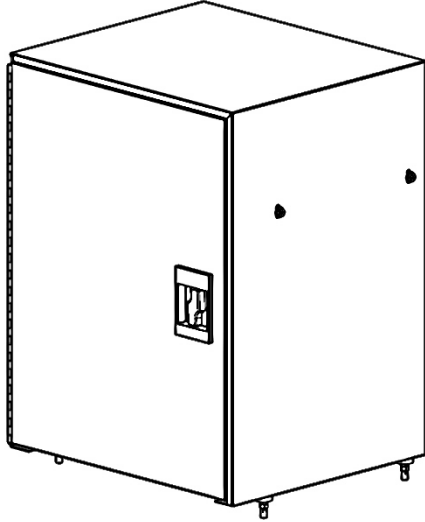
## Parts List

ITEM NO.		PART NUMBER	DESCRIPTION	QTY.
A		40170-10	BOX	1
		18-40170	BOX HARDWARE	1

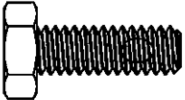
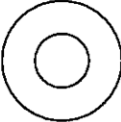
## Hardware

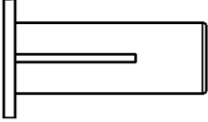
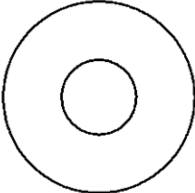
ITEM NO.	TO SCALE	PART NUMBER	DESCRIPTION	QTY.
1		92865A544	1/4"-20 x 1-1/4" Hex Head	4
2		90019A120	1/4"-20 x 3/4" HH	4
3		90126A029	1/4" Flat Washer	12
4		95615A120	1/4"-20 Nyloc	8
5		.25-20 Plus Nut	1/4"-20 Plus Nut	4
6		.375 x 1.00D x .39ID Nylon Spacer		4

## Step 1 – Find Mounting Location

- Find desired location for cabinet to be installed.
- Mark through the four holes in the box, onto the floor of the vehicle.
- On the side of most Holman shelf units, holes can be found that may also be used for this installation. If there are not holes that line up, you may mark hole locations and drill with 5/16" drill bit.

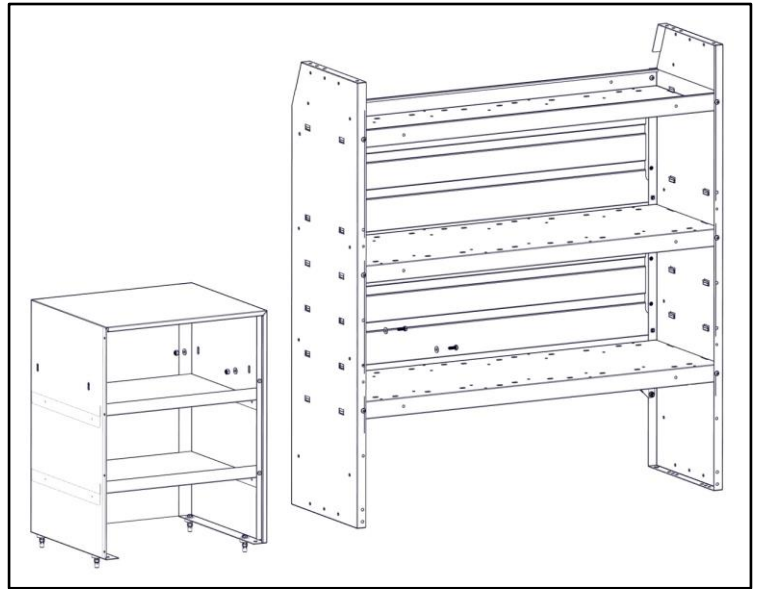

## Step 2 – Install Plus Nuts



**DO NOT drill beyond depth of floor or upper installation surface. Always check for wires, fuel tanks and lines, brake lines and other important vehicle functionality items prior to drilling and installing all products.**

- At each marked location, drill hole using 25/64" drill bit and appropriate sized drill-bit stop collar. If 25/64" drill bit is not available, a 3/8" drill bit can be used, although it may be necessary to tap in the plus nuts.
- Insert 1/4" x 2-1/4" hex head bolt through 1/4" flat washer and plus nut installation tool, and then screw bolt into plus nut. Knurled end of plus nut tool must be directed away from bolt head and contacting plus nut.
- Insert plus nut into hole with plus nut tool attached.
- Using the 9/16" box wrench, hold the plus nut tool stationary and then tighten hex head bolt until plus nut is tightly gripping and does not spin when hex bolt is loosened.
- DO NOT overtighten plus nut.
- Using the 9/16" box wrench, hold the plus nut tool stationary to remove the 1/4" hex head bolt.

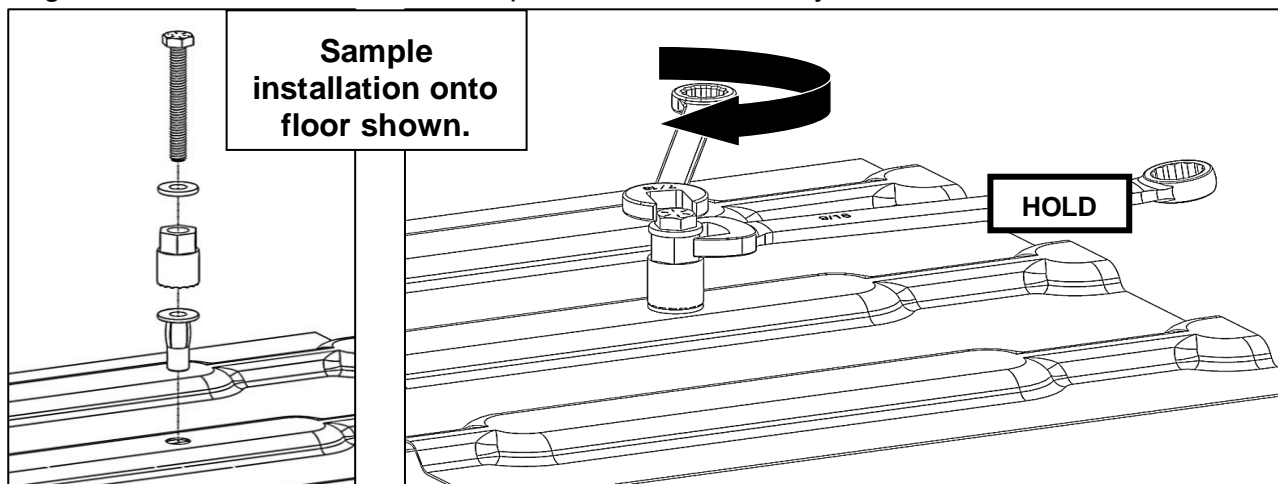

## Step 3 – Install Box

- Bolt to shelf, partition and/or floor using provided hardware.
- If needed place nylon spacer under box to fill the gap between the bottom of the box and the floor. **Be sure the box is aligned and squared or the door may not function as intended.**

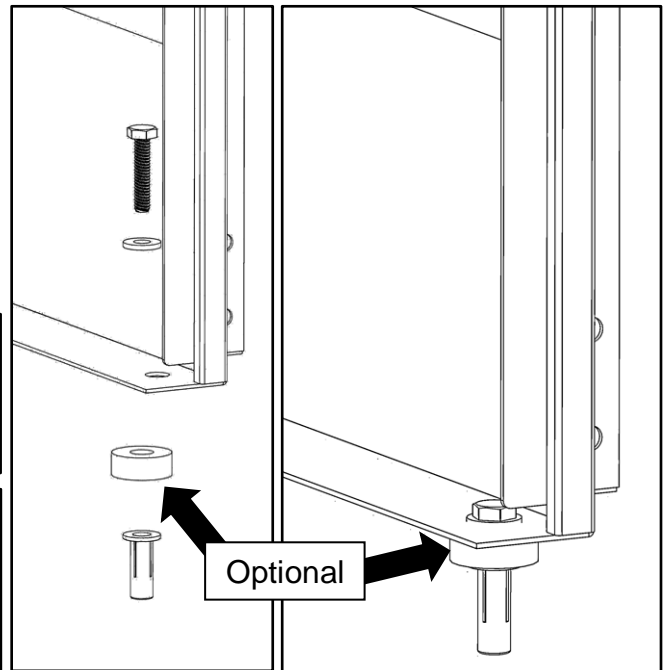
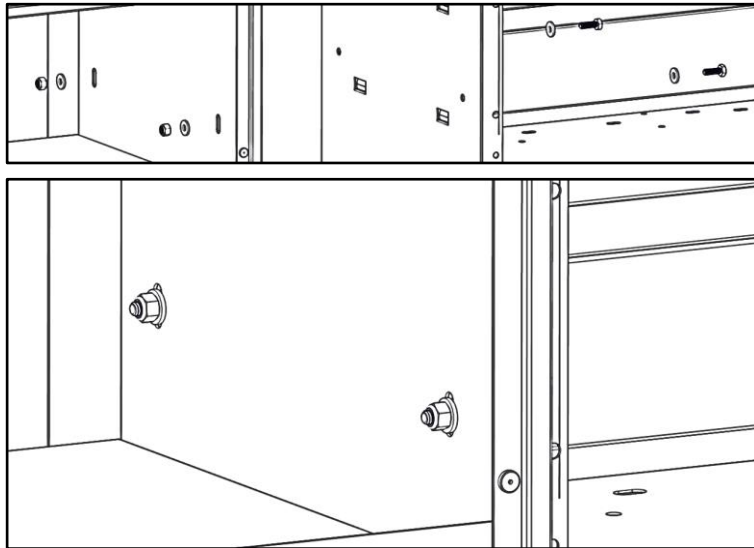

**GO BACK AND TIGHTEN ALL HARDWARE.**

**INSTALLATION IS COMPLETE.**

