

# Holman

---

## Instruction Guide 40291

---

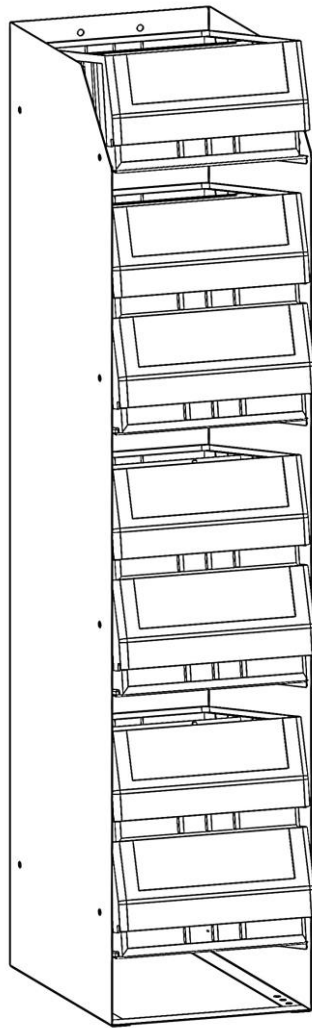

---

Holman  
Rancho Cordova, CA 95742  
800-343-7486  
[InstallationSupport@Holman.com](mailto:InstallationSupport@Holman.com)

---

**PLEASE READ ALL INSTRUCTIONS AND WARNINGS PRIOR TO ASSEMBLING, INSTALLING, AND USING THIS PRODUCT.**

**Warning**



**Always check for wires, fuel tanks and lines, brake lines and other important vehicle functionality items prior to drilling and installing all products.**

**Tools Needed**

7/16" Socket and Wrench	7/16", 9/16" Box Wrenches
9/32", 25/64" Drill Bits	Drill
#2 Phillips Screwdriver	Drill Bit Stop Collar
Plus Nut Installation Tool (P9902)*	

\* Sold Separately.

**Table of Contents**

Before You Begin ..... 1

Parts List ..... 2

Hardware ..... 2

Step 1 – Find Mounting Location..... 3

Step 2 – Install Plus Nuts..... 3

Step 3 – Mount Binder/Bin Holder to Shelf ..... 4

Step 4 – Mount Binder Holder to Floor..... 4



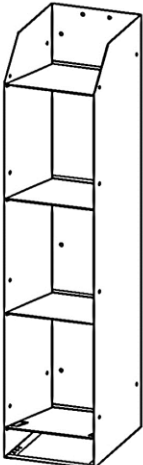
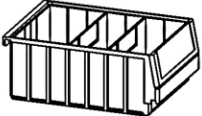

**Before You Begin**

- Read all instructions prior to assembling or installing any Holman product.
- **Always locate your installation locations prior to performing any work.**
- **ENSURE SAFETY WHILE INSTALLING OR DRILLING INTO VEHICLE.**
- **Plus Nut Installation Tool Kit (P9902) is not included and must be purchased separately.**

## Parts List

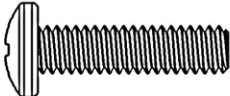
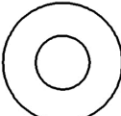
NO.	ITEM	PART NUMBER	DESCRIPTION	QTY.
1		101040	BINDER/BIN HOLDER ASM	1
2		40311	LARGE PLASTIC BIN EXT W/ DIVIDERS	7
3		18-40280	HARDWARE KIT	1

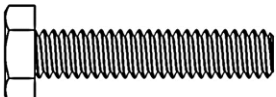
## Hardware

ITEM	HARDWARE TO SCALE	PART NUMBER	DESCRIPTION	QTY.
1		29184	1/4"-20 X 1" PHILIPS HEAD SCREW	4
2		33078	1/4" WASHER	10
3		37018	1/4"-20 NYLON INSERT LOCK NUT	4
4		-	25/64" ID X 1" OD X 3/8" NYLON SPACER	2
5		13800	1/4"-20 X 1-1/4" FT HEX HEAD BOLT	2
6		1133618	1/4"-20 LOCK WASHER	2
7		920313726	1/4"-20 PLUS NUT	2

## Step 1 – Find Mounting Location

There are holes in both sides and the rear of binder/bin holder to allow for a variety of mounting positions.

- Determine installation location. It is recommended to install binder/bin holder to the side of shelf or to a partition.
- Position binder/bin holder in desired installation location and position.
- Mark onto floor location of **TWO** holes in bottom of binder/bin holder to be used for installation.
- Mark onto shelf (or other installation location) the position of **FOUR** holes in side of binder/bin holder to be used for installation.

## Step 2 – Install Plus Nuts



**DO NOT drill beyond depth of floor or upper installation surface. Always check for wires, fuel tanks and lines, brake lines and other important vehicle functionality items prior to drilling and installing all products.**

- At each marked location, drill hole using 25/64" drill bit and appropriate sized drill-bit stop collar. If 25/64" drill bit is not available, a 3/8" drill bit can be used, although it may be necessary to tap in the plus nuts.
- Insert 1/4" x 2-1/4" hex head bolt through 1/4" flat washer and plus nut installation tool, and then screw bolt into plus nut. Knurled end of plus nut tool must be directed away from bolt head and contacting plus nut.
- Insert plus nut into hole with plus nut tool attached.
- Using the 9/16" box wrench, hold the plus nut tool stationary and then tighten hex head bolt until plus nut is tightly gripping and does not spin when hex bolt is loosened.
- DO NOT overtighten plus nut.
- Using the 9/16" box wrench, hold the plus nut tool stationary to remove the 1/4" hex head bolt.

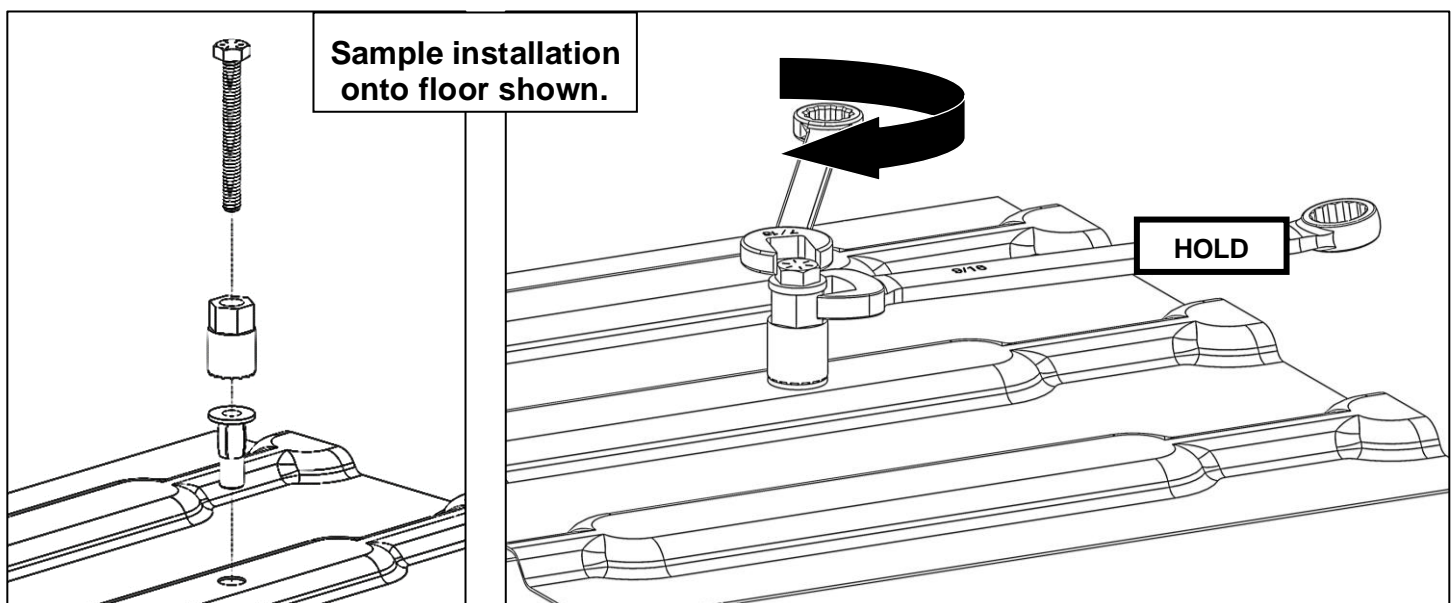

## Step 3 – Mount Binder/Bin Holder to Shelf

- At each location marked on shelf or other mounting location, drill through surface using a 9/32" drill bit.
- Using four 1/4" x 1" Phillips head screws, eight 1/4" flat washers, and four 1/4" lock nuts, **LOOSELY** bolt through the binder/bin holder and shelf.
- **DO NOT TIGHTEN** hardware yet.

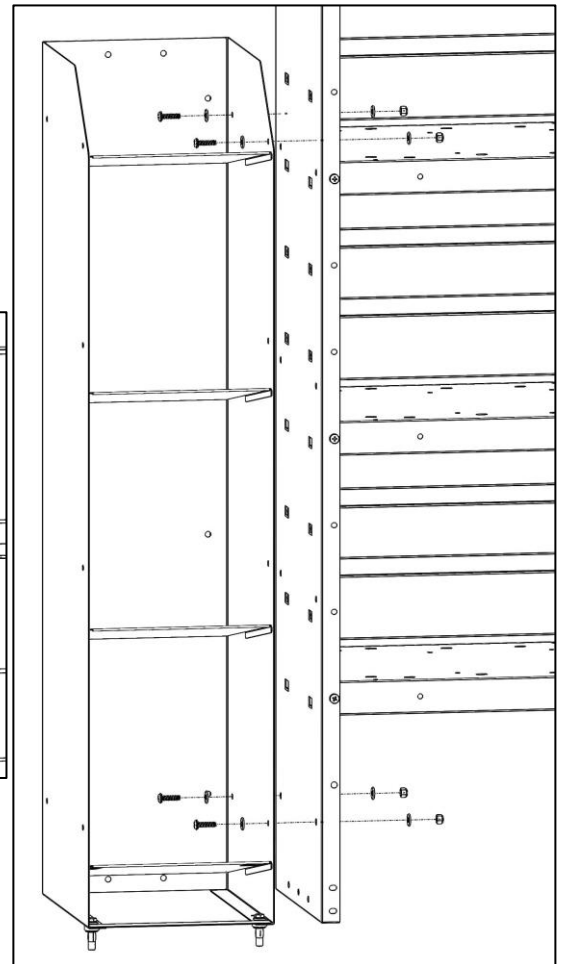
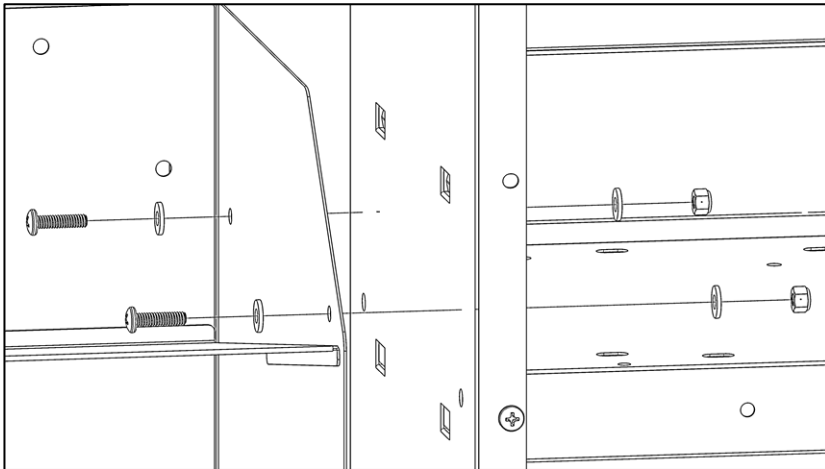

## Step 4 – Mount Binder Holder to Floor

If a gap exists between the binder/bin holder and the installation location in the floor, nylon spacers are provided to fill the gap.

- Press assembly firmly against the floor.
- Using 1/4" x 1-1/4" hex head bolts, 1/4" lock washers, 1/4" flat washers, and, if necessary, nylon spacers, bolt through the base of the assembly into the plus nuts.
- Tighten hardware.

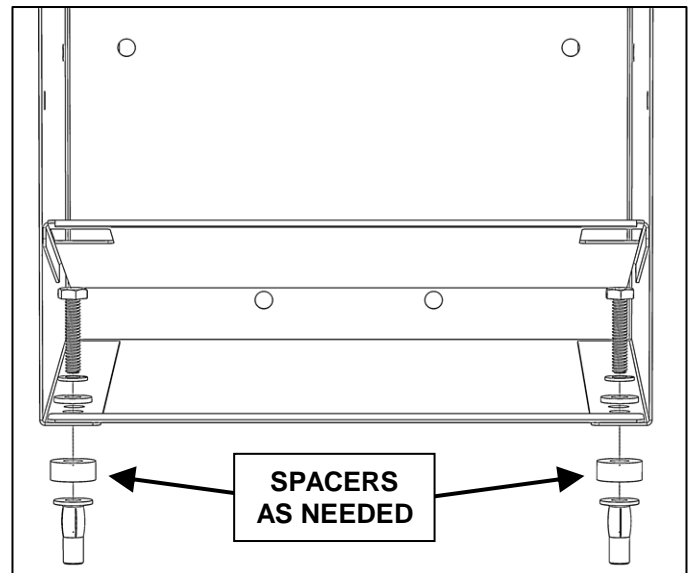

**GO BACK AND TIGHTEN ALL HARDWARE.**

**INSTALLATION IS COMPLETE.**