

Holman

Installation Guide 40480

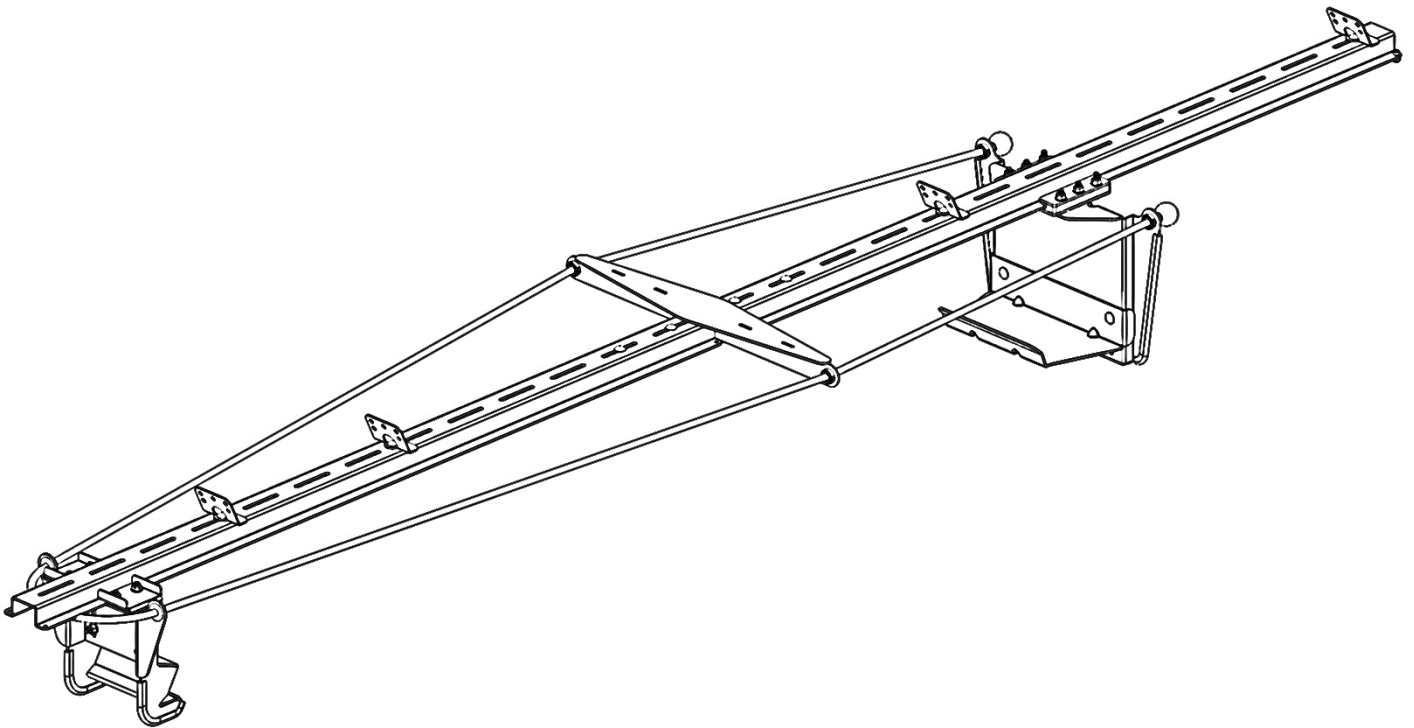

Holman
Rancho Cordova, CA 95742
800-343-7486
InstallationSupport@Holman.com

PLEASE READ ALL INSTRUCTIONS AND WARNINGS PRIOR TO ASSEMBLING, INSTALLING, AND USING THIS PRODUCT.

Warning



Always check for wires, fuel tanks and lines, brake lines and other important vehicle functionality items prior to drilling and installing all products.



DO NOT EXCEED MANUFACTURERS WEIGHT CAPACITY FOR ROOF.

Tools Needed

7/16", 9/16" Box Wrenches	5/32" Allen Wrench
5/16", 7/16" Sockets and Wrench	Drill
25/64" Drill Bit	Drill Bit Stop Collar
Plus Nut Installation Tool (P9902)*	Torpedo Level

* Sold Separately.



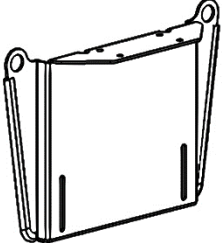

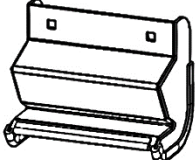
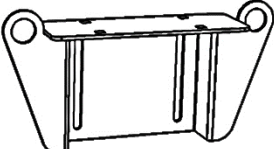
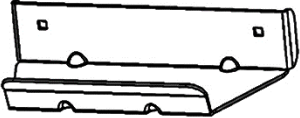

Table of Contents

Parts List	2
Assembly Hardware.....	3
Mounting Hardware.....	4
Plus Nut Installation	5
Bungee Cord Cutting Guidelines	5
Step 1 – Mounting Bracket Installation	6
Step 2 – Ladder Catch Assembly.....	9
Step 3 – Mounting the Rail	10
Step 4 – Sliding Pan Assembly	11
Step 5 – Bungee Assembly	12
Alternate Installation Method	14
Use Instructions	14
Maintenance Instructions.....	14



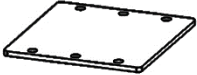

Before You Begin

- Read all instructions. Locate your mounting locations prior to rack assembly.
- **BE SURE TO ADJUST LADDER BUNGEE CLAMP ACCORDINGLY TO FIRMLY SECURE LADDER TO RACK.**
- **ENSURE SAFETY WHILE INSTALLING OR DRILLING INTO VEHICLE.**
- **Plus nut installation tool (P9902) is not included and must be purchased separately.**



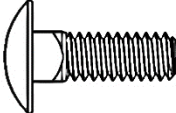

Parts List

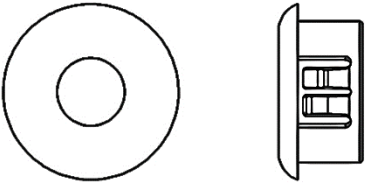
ITEM NO.	ITEM	PART NUMBER	DESCRIPTION	QTY.
1		100500	HORIZONTAL RAIL	2
2		100501	CENTER SUPPORT	1
3		101000	SLIDING BRACKET ASSEMBLY	1
4		100503	SLIDER BLOCK, PLASTIC	2
5		100505	CLAMPING BRACKET	2
6		101001	FIXED-END LADDER-CATCH BRACKET ASSEMBLY	1
7		100510	REAR SUPPORT BRACKET	1
8		100511	LADDER SUPPORT HOOK	1
9		100655	UPPER SLIDER BRACKET	2
10		100658	LOWER SLIDER BRACKET	1
11		18-40480M	MOUNTING HARDWARE KIT	1
12		18-40480A	ASSEMBLY HARDWARE KIT	1

Assembly Hardware

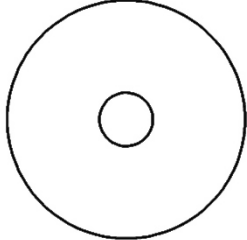
ITEM	HARDWARE TO SCALE	PART NUMBER	DESCRIPTION	QTY.
1		0167030	1/4"-20 FLANGED LOCK NUT	18
2		21801	1/4"-20 X 3/4" CARRIAGE BOLT	12
3		94054	1/4"-20 X 1-1/4" BUTTON HEAD CAP SCREW	6
4		37014	10-24 NYLON INSERT LOCK NUT	1
5		11137140	10-24 X 3/8" SOCKET CAP SCREW	1
6	 (1:2 SCALE)	B07L24CVQC	BUNGEE BALL, 8MM	2
7			BUNGEE CORD, 8MM	1
8		S 750-5 (2535)	3/4" SNAP-IN BUSHING	6

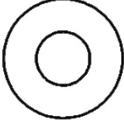
Mounting Hardware

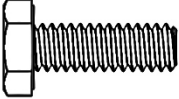
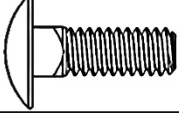
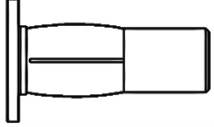
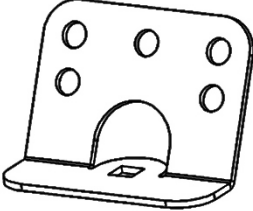
ITEM	HARDWARE TO SCALE	PART NUMBER	DESCRIPTION	QTY.
1		33208	1/4" FENDER WASHER	4
2		1133618	1/4"-20 LOCK WASHER	8
3		33078	1/4" FLAT WASHER	8
4		0167030	1/4"-20 FLANGED LOCK NUT	8
5		11241345	1/4"-20 X 3/4" HEX HEAD BOLT	8
6		21801	1/4"-20 X 3/4" CARRIAGE BOLT	4
7		920313726	1/4"-20 PLUS NUT	8
8		100506	65 DEGREE MOUNTING BRACKET	4

Plus Nut Installation



DO NOT drill beyond depth of floor or upper installation surface. Always check for wires, fuel tanks and lines, brake lines and other important vehicle functionality items prior to drilling and installing all products.

- Drill hole using 25/64" drill bit. If 25/64" drill bit is not available, a 3/8" drill bit can be used, although it may be necessary to tap in the plus nuts.
- Insert 1/4" x 2-1/4" hex head bolt through plus nut installation tool, and then screw bolt into plus nut. Knurled end of plus nut tool must be directed away from bolt head and contacting plus nut.
- Insert plus nut into hole with plus nut tool attached.
- Using the 9/16" box wrench, hold the plus nut tool stationary and then tighten hex head bolt until plus nut is tightly gripping and does not spin when hex bolt is loosened. **DO NOT** overtighten plus nut.
- Using the 9/16" box wrench, hold the plus nut tool stationary to remove the 1/4" hex head bolt.

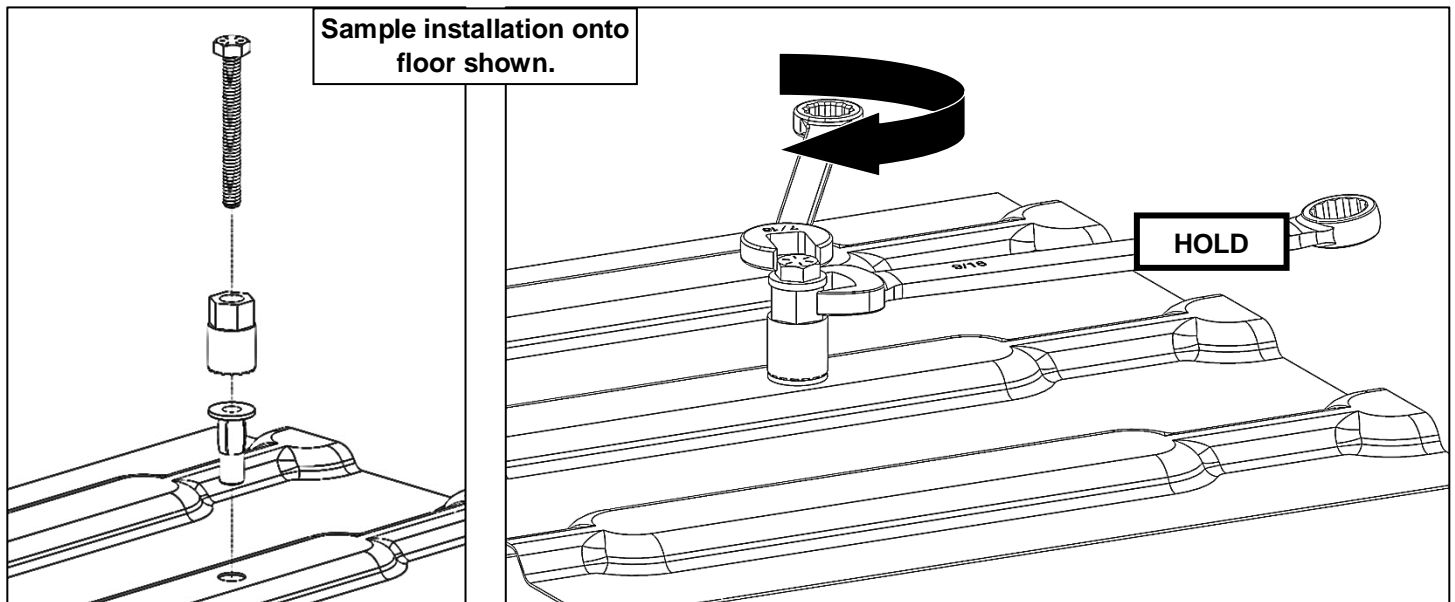

Bungee Cord Cutting Guidelines

- Determine location to cut.
- Wrap packing tape or other permanent tape around bungee cord, centered at location.
- Use either a hot knife or a razor knife to cut through center of tape.
- Burn each end until just melting materials together.

Step 1 – Mounting Bracket Installation

Installation using plus nuts is recommended. Hardware has been included for alternative method of installation, depending on the vehicle.

- Obtain four 1/4" x 3/4" carriage bolts and four 1/4" lock nuts from assembly hardware package.
- Lightly attach the horizontal rails to the center support using four 1/4" x 3/4" carriage bolts and four 1/4" flanged lock nuts. Do not secure tightly as the assembly may need adjustment or modification.

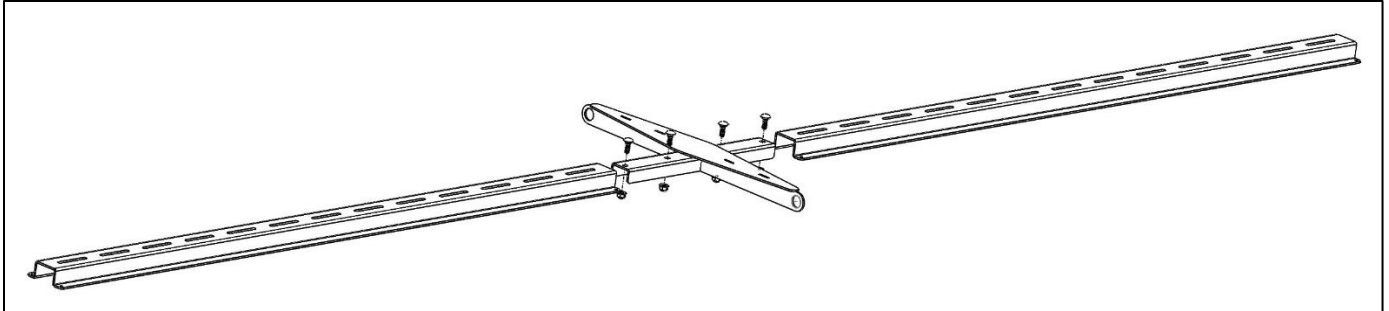

- Locate and mark center of roof support beams.
- Hold rail assembly against center of roof support beams.

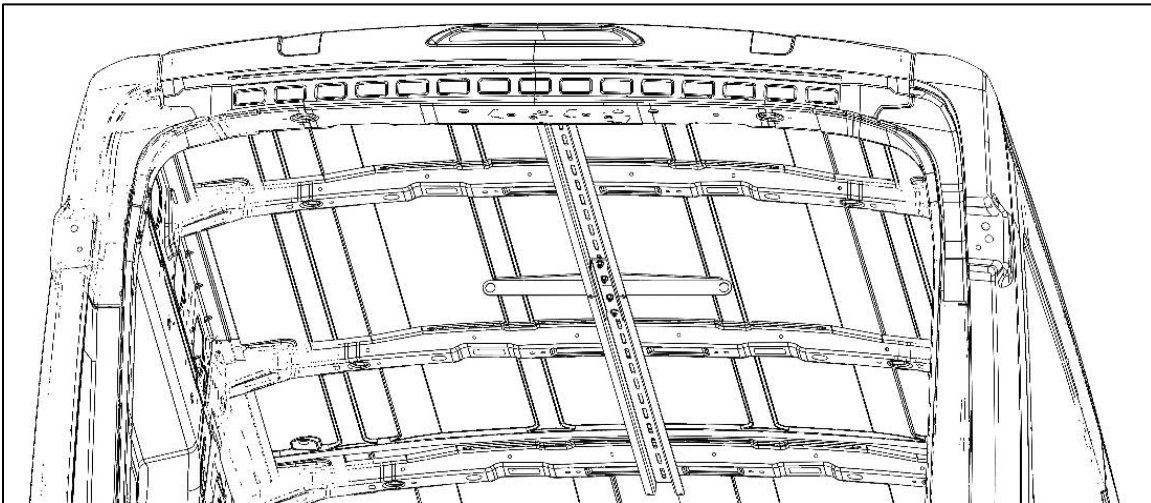

- If the rail assembly is too long, either mark or measure the length of horizontal rail that needs to be removed. The length of the uncut assembled rail assembly is 96".
- To cut off a section of horizontal rail, disassemble the rail assembly, cut the desired length from the REAR end rail, and reassemble rail assembly with the cut end towards the center support. It is recommended to cut the horizontal rail between two of the mounting slots in the rail.

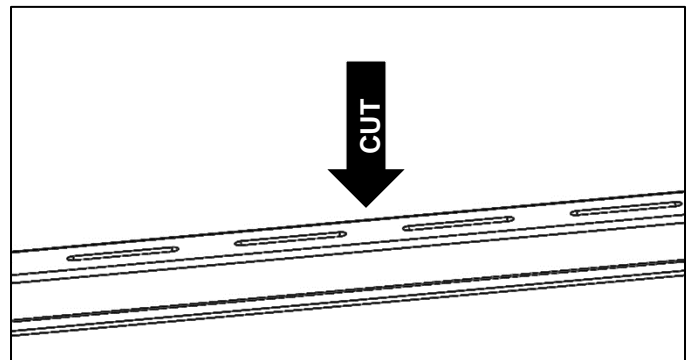

If rail is cut to fit, rail must be installed with small hole at end of assembly furthest from center.

- Obtain two mounting brackets from mounting hardware kit.

- Hold one mounting bracket against the center of rear roof support beam. Be sure the mounting bracket is level to the roof support beam. Mark two mounting-hole locations on the roof support beam.

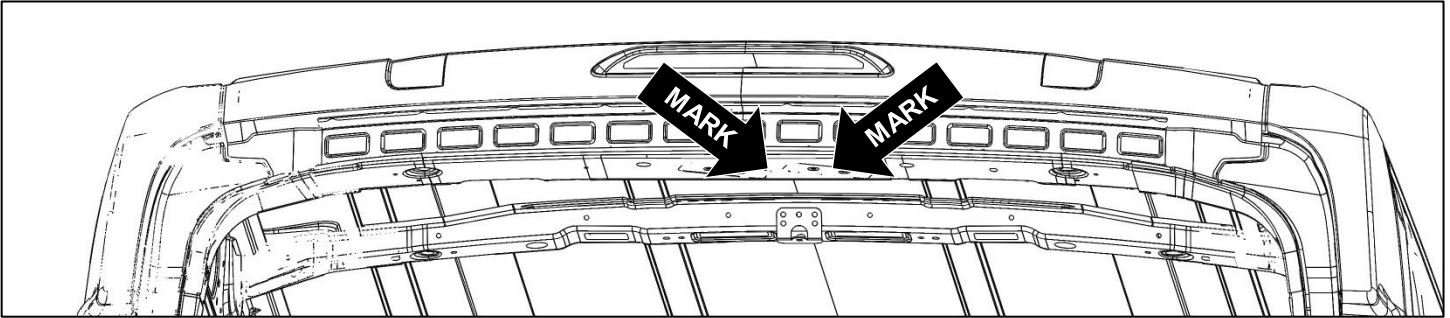

- Hold second mounting bracket against the center of forward roof support beam. Be sure the mounting bracket is level to the roof support beam. Mark mounting hole locations on the roof support beam.

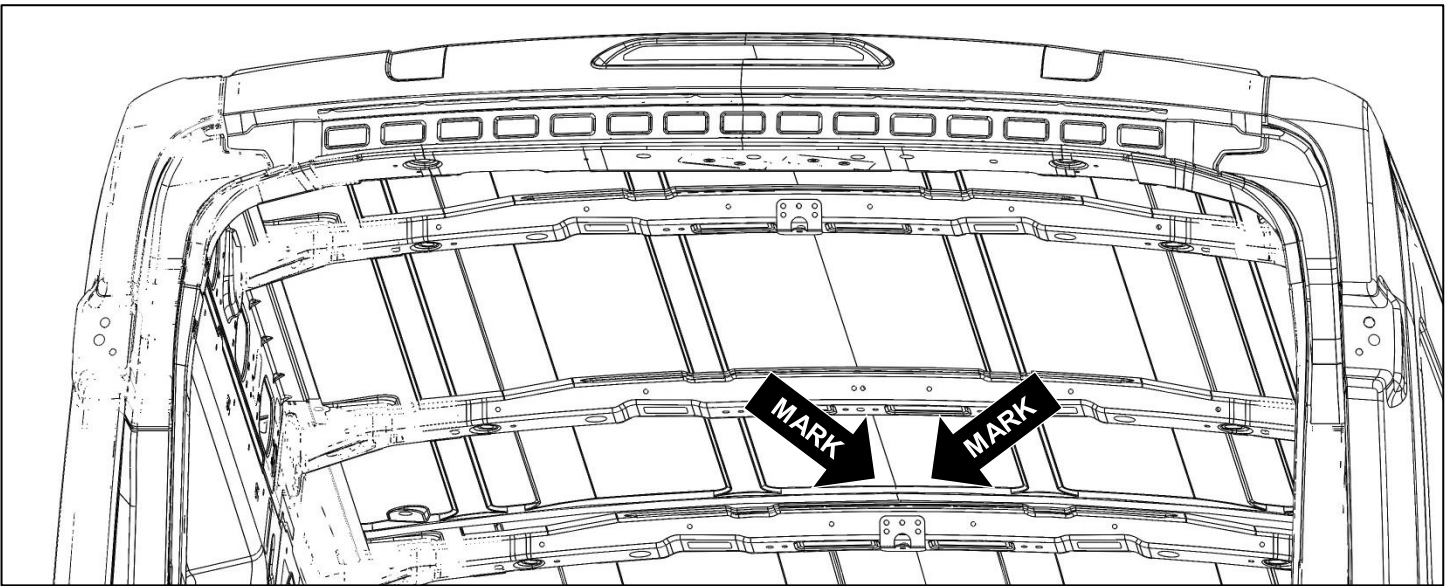

- Per the Plus Nut Installation instructions above, drill holes and install plus nuts at the locations marked on the roof support beams.
- Using two 1/4" x 3/4" hex head bolts, 1/4" lock washers, and 1/4" flat washers for each mounting bracket location, install mounting brackets to plus nuts so the bolts are just barely snug.
- Using two 1/4" x 3/4" carriage bolts, two 1/4" fender washers, and two 1/4" lock nuts, attach rail assembly to installed mounting brackets.
- Tighten lock nuts until horizontal rail is just barely snug against mounting bracket.
- At each of the remaining roof support beams, using a 1/4" x 3/4" carriage bolts, a 1/4" fender washer, and a 1/4" lock nut, loosely attach a mounting bracket to the rail assembly.

- Mark the locations through the mounting bracket holes onto the roof support beam.

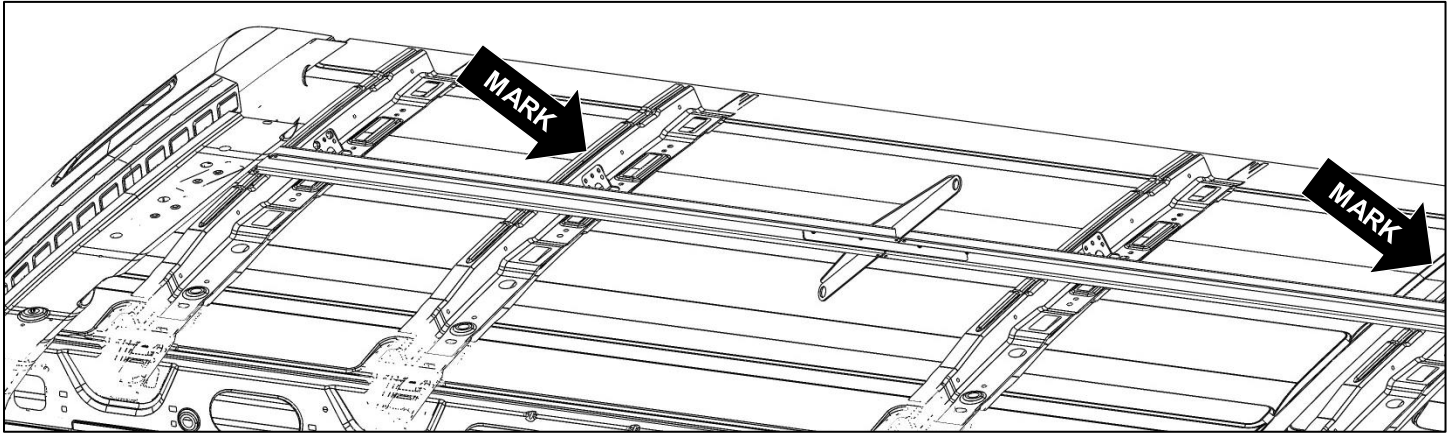

- Make a mark on rail 11" from the rear of van interior ceiling. This mark will be needed during assembly.

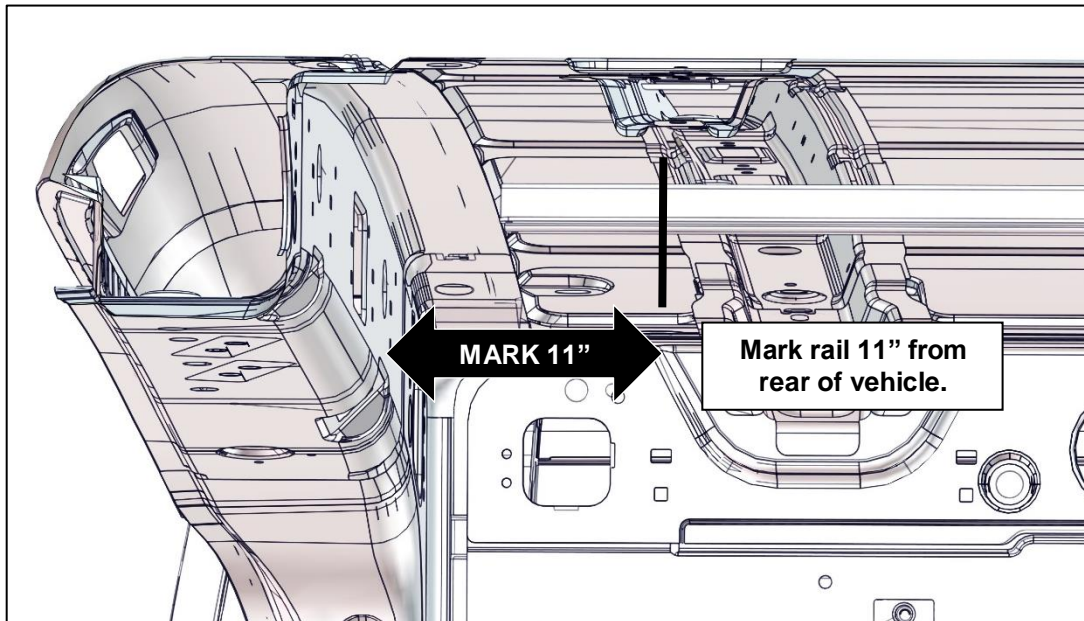

- Keep the front and rear mounting brackets attached to the roof support beams, remove rail assembly and other mounting brackets from roof support beams.
- Per the Plus Nut Installation instructions above, drill holes and install plus nuts at the locations marked on the roof support beams.
- Snug tighten hardware but allowing for movement, install the mounting brackets to the roof support beams.

Step 2 – Ladder Catch Assembly

- Using two 1/4" x 3/4" carriage bolts and two 1/4" flanged lock nuts per each clamping bracket, loosely attach clamping brackets to top of rear support bracket. Be sure short flange on each clamping bracket is pointing downward and away from center of rear support bracket.
- Using two 1/4" x 3/4" carriage bolts and two 1/4" flanged lock nuts, attach fixed-end ladder catch to rear support bracket.
- Tighten nuts until just barely snug. Carriage bolt heads should be towards front of catch.

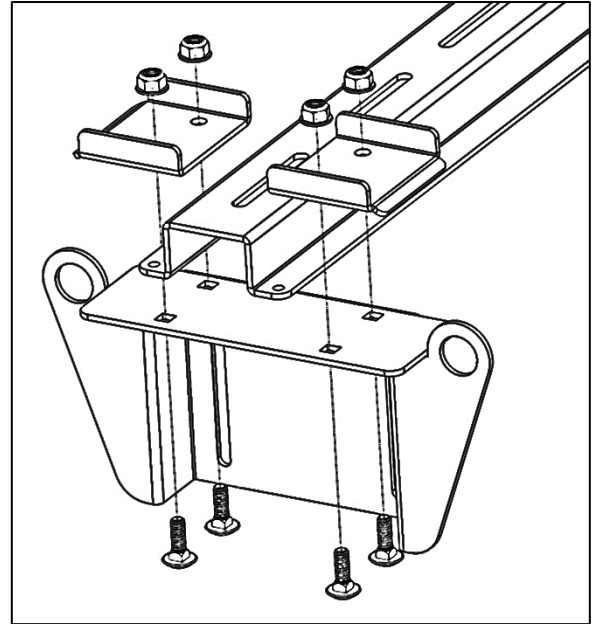
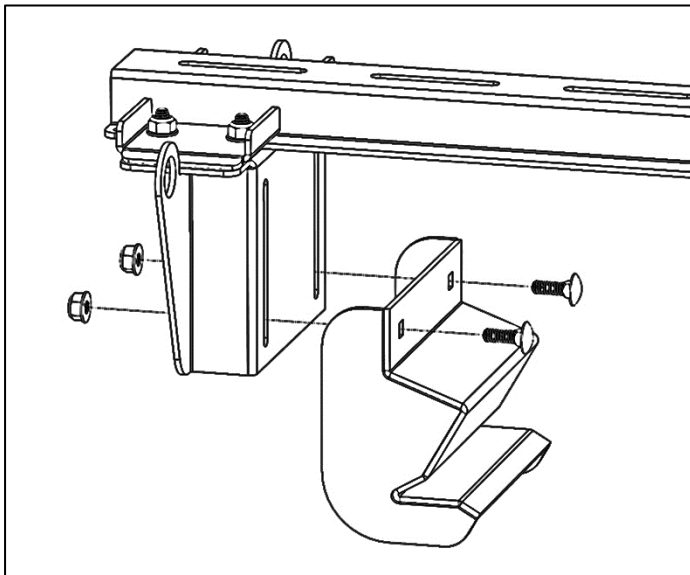

- Slide assembly along rail until forward end of clamping bracket is aligned with 11" distance mark made on rail in previous step. Most stepladders require 11" clearance between bottom of first step and rear of van ceiling and/or rear doors.
- Tighten nuts on clamping brackets until ladder catch assembly is securely fastened in place.

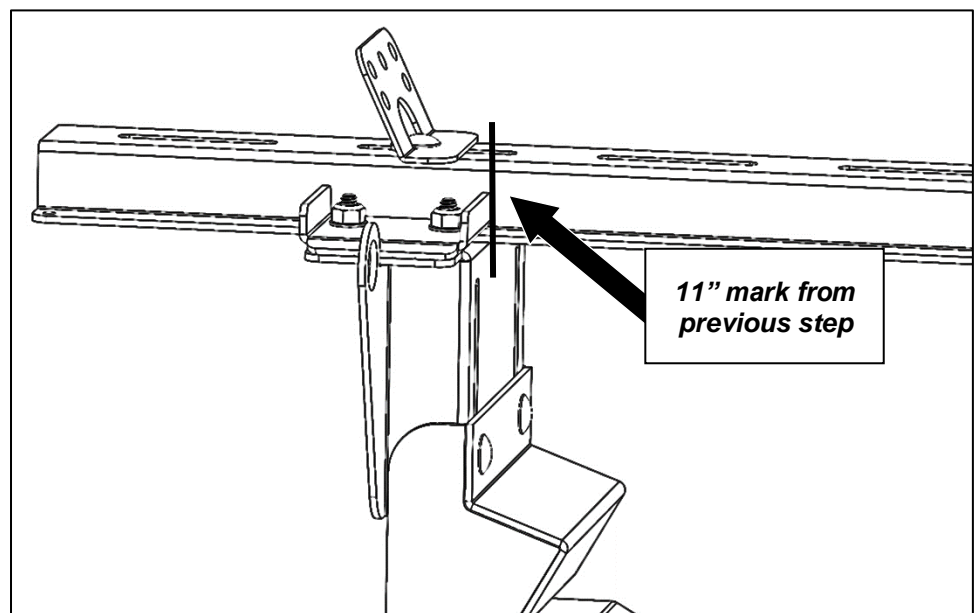

- Insert a snap bushing into each side of rear support bracket with round face towards rear of vehicle. Note the direction of the snap bushing. Inserting snap bushing in wrong direction will result in unnecessary wear on bungee cord.

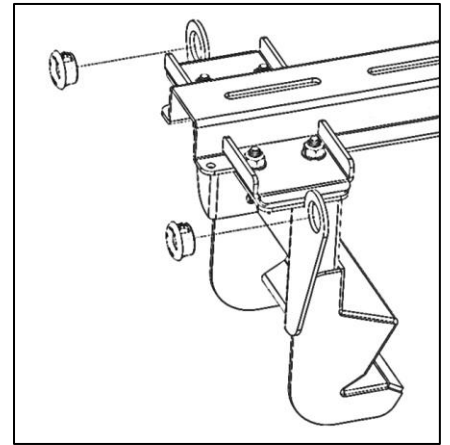

Step 3 – Mounting the Rail

- Insert a snap bushing into each side of center support with round face towards front of vehicle. Note the direction of the snap bushing. Inserting snap bushing in wrong direction will result in unnecessary wear on bungee cord.

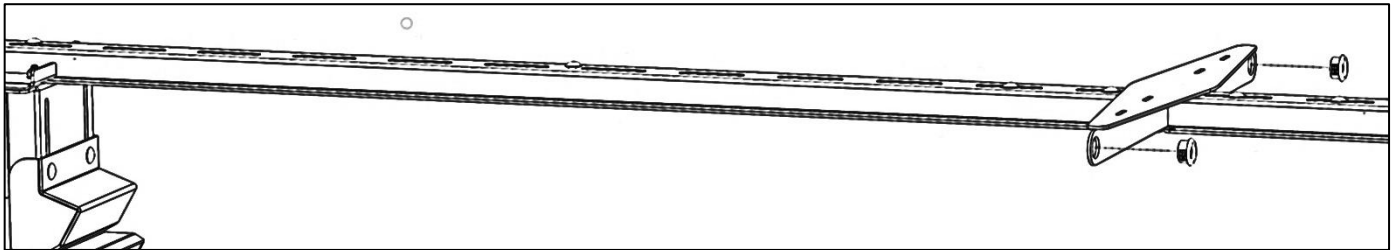

- Lift rail assembly, with ladder catch assembly attached, to roof mounting locations.
- Using two 1/4" x 3/4" hex head bolts, 1/4" flat washers, and 1/4" lock washers for each mounting bracket location, install mounting brackets to previously installed plus nuts. **DO NOT over tighten.**
- Tighten all nuts to mounting bracket carriage bolts.

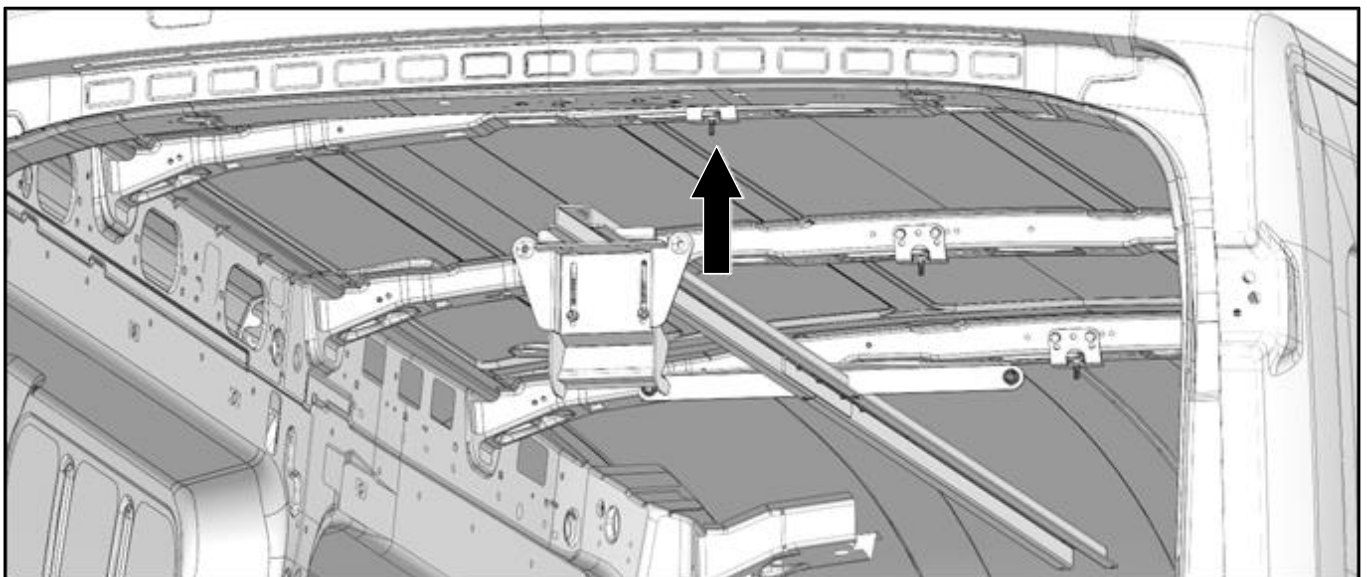

Step 4 – Sliding Pan Assembly

- Using three 1/4" x 1-1/4" button head screws and three 1/4" flanged lock nuts on each side, attach lower slider plate, slider blocks, and upper slider plates to the top of the sliding bracket.
- Snugly tighten lock nuts. DO NOT overtighten lock nuts.
- Using two 1/4" x 3/4" carriage bolts and two 1/4" flanged lock nuts, attach sliding ladder hook to sliding bracket. Carriage bolt heads should be towards the pan of the sliding ladder hook.
- Tighten nuts until just barely snug.

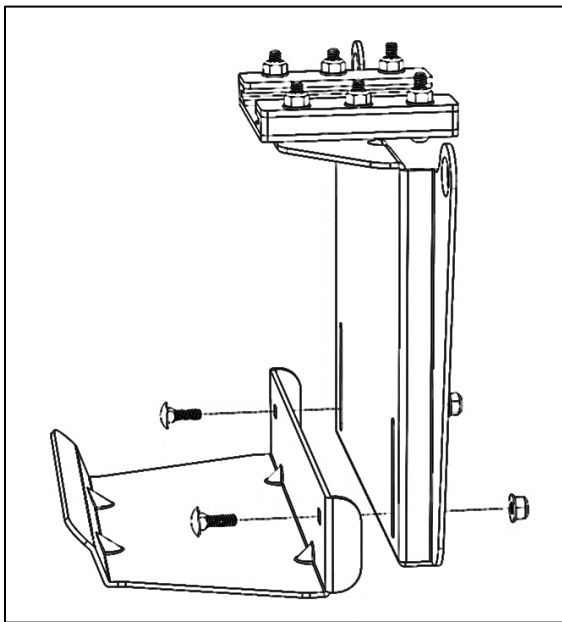
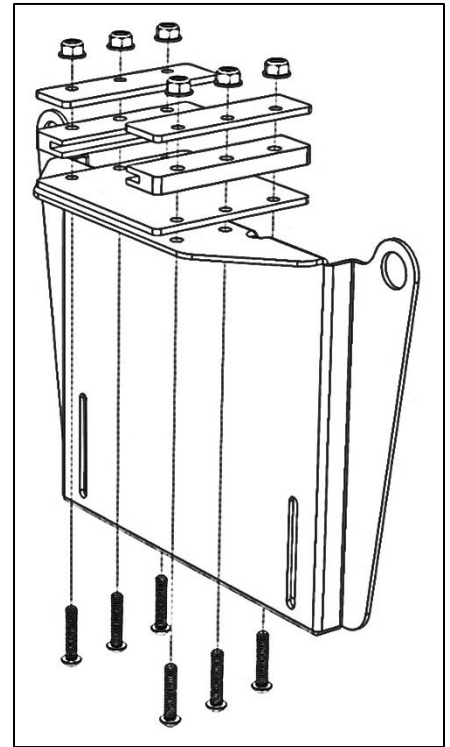

- With hook pointed towards rear, slide slots in sliding hook assembly over rail flanges at forward end of rail assembly.

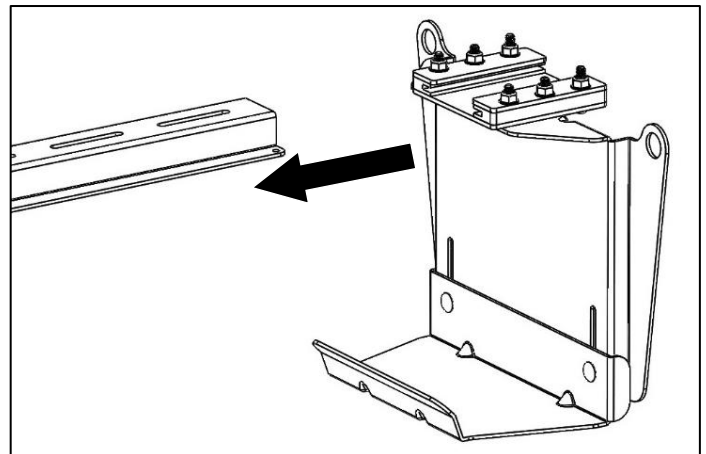

- Insert a snap bushing into each side of sliding bracket with round face towards front of vehicle. Note the direction of the snap bushing. Inserting snap bushing in wrong direction will result in unnecessary wear on bungee cord.

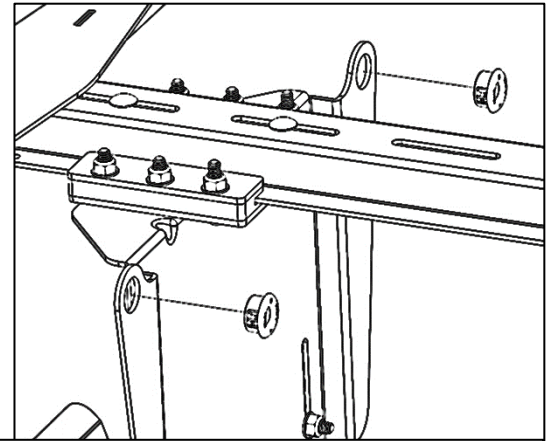

- Install 10-24 x 3/8" socket cap screw and 10-24 lock nut in hole at end of rail behind sliding bracket assembly.
- Tighten.

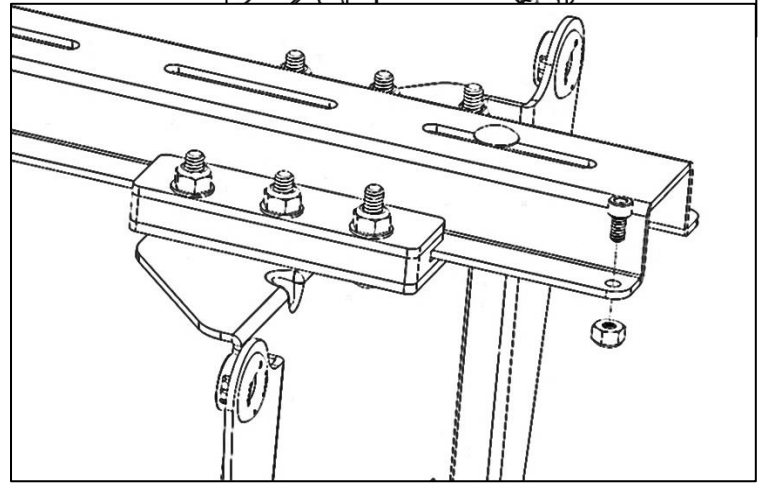

The 10-24 x 3/8" socket cap screw and 10-24 lock nut are safety stops and must remain in place at all times during transport and use.

Step 5 – Bungee Assembly

- If ladder rack will be used only with 6 ft. stepladder, cutting the bungee cord is recommended. It is recommended to mark the appropriate length on the bungee cord with tape, and only cut the bungee after the bungee cord has been strung through the ladder rack. The following are the recommended bungee cord lengths per ladder size of the supplied bungee cord.

Ladder Size	Bungee Cord Cut Length
8 ft.	10 ft.
6 ft.	8 ft. 4 in.

- Insert end of bungee cord into smaller hole on bungee ball and out larger hole on bungee ball.
- Tie a knot into end of bungee cord.
- Pull on bungee cord until knot snaps into larger hole on bungee ball.

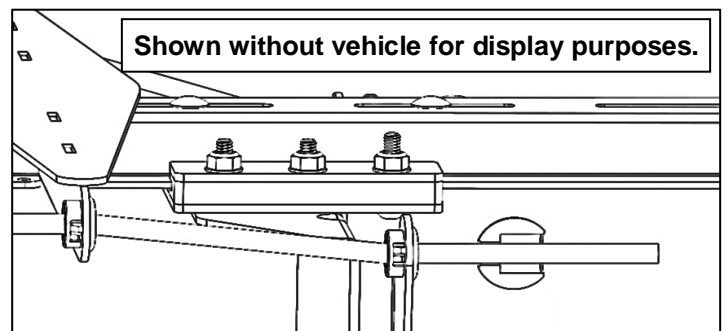

- Thread bungee cord through snap bushings on one side of ladder rack and then back through opposite side snap bushings.
- Insert bungee cord into small hole and out larger hole in second bungee ball.

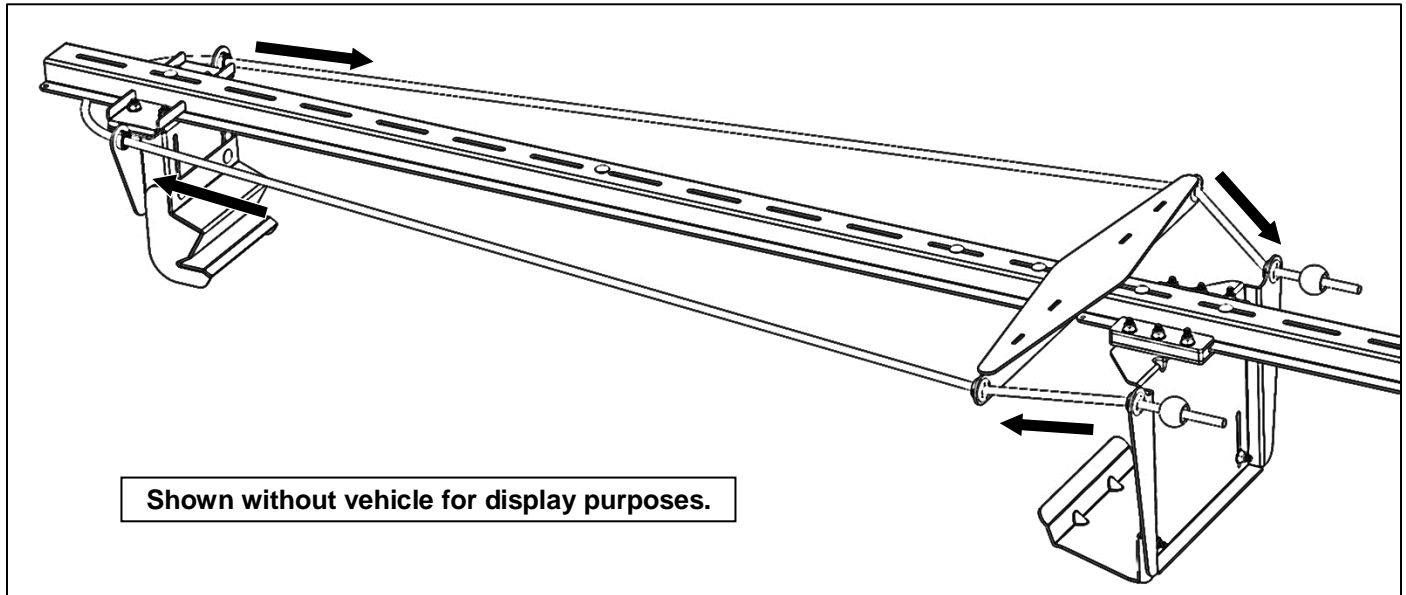

- Tie a knot in the bungee cord a few inches either before the end of the bungee cord or before the tape marker.
- Pull on bungee cord until knot snaps into larger hole on bungee ball.
- If cutting the bungee cord, cut bungee cord per Bungee Cord Cutting Guidelines above.
- Tighten all hardware.

MAKE SURE ALL HARDWARE IS TIGHT.

INSTALLATION IS NOW COMPLETE.

Alternate Installation Method

- For some vehicles, it may be desirable to install the mounting brackets alternatively using 1/4" x 3/4" hex bolts, 1/4" flat washers, and 1/4" flanged lock nut through the top center hole of the mounting bracket into the roof support beam.

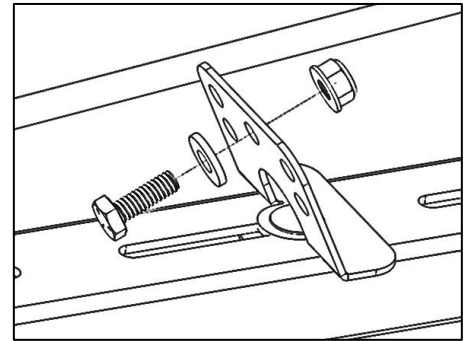

Use Instructions

- Position ladder with thicker front ladder section downward and top of ladder towards front of vehicle.
- Set top of ladder onto sliding ladder hook.
- Push ladder forward and upward.
- Lock ladder into ladder catch assembly.



Always verify that ladder is tightly secure in ladder rack. If ladder is mounted and still loosely secured, bungee cord length may need to be reduced.



IF BUNGEE CORD IS DAMAGED OR DECAYING IN ANY WAY, REPLACE BUNGEE CORD IMMEDIATELY.

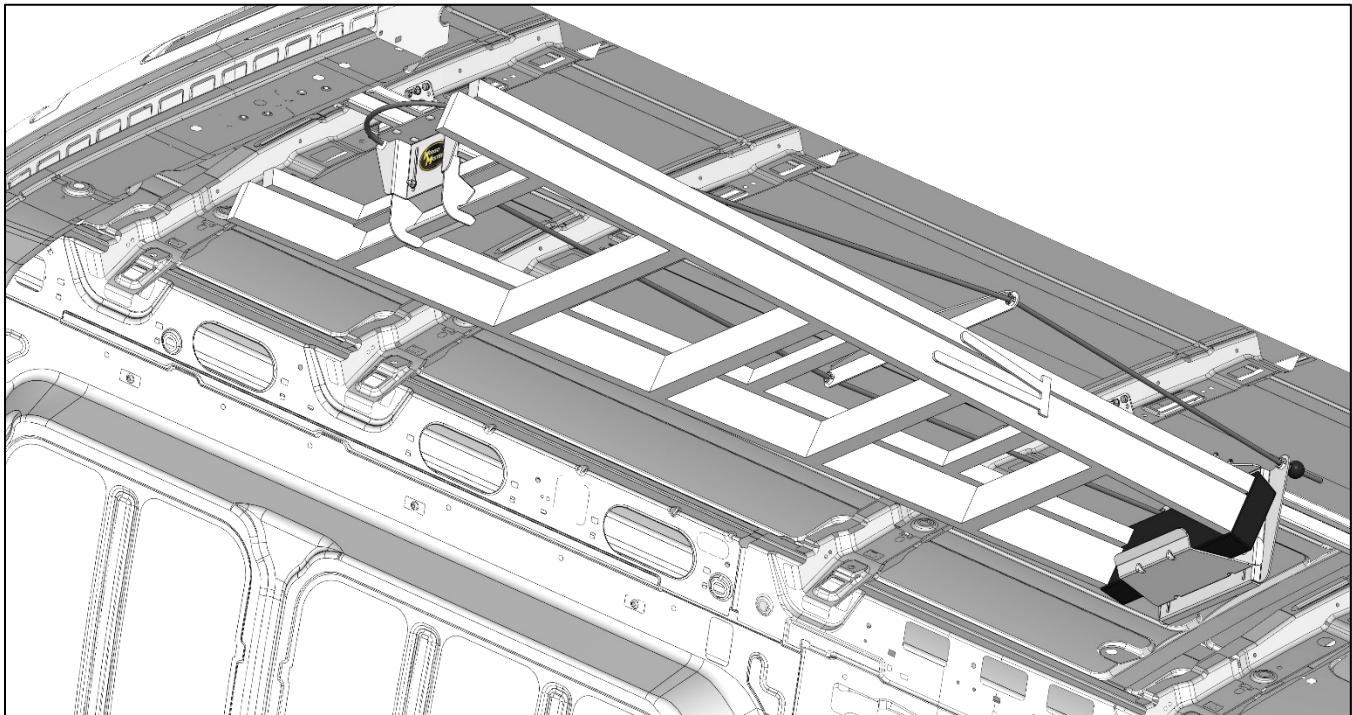

Maintenance Instructions

- Wipe down rail occasionally to remove any dust build up on rail.
- If rail starts to slide uneasily, wipe down rail with rubbing alcohol to remove any dirt or grease build up.