

Holman

Installation Guide

40601SH

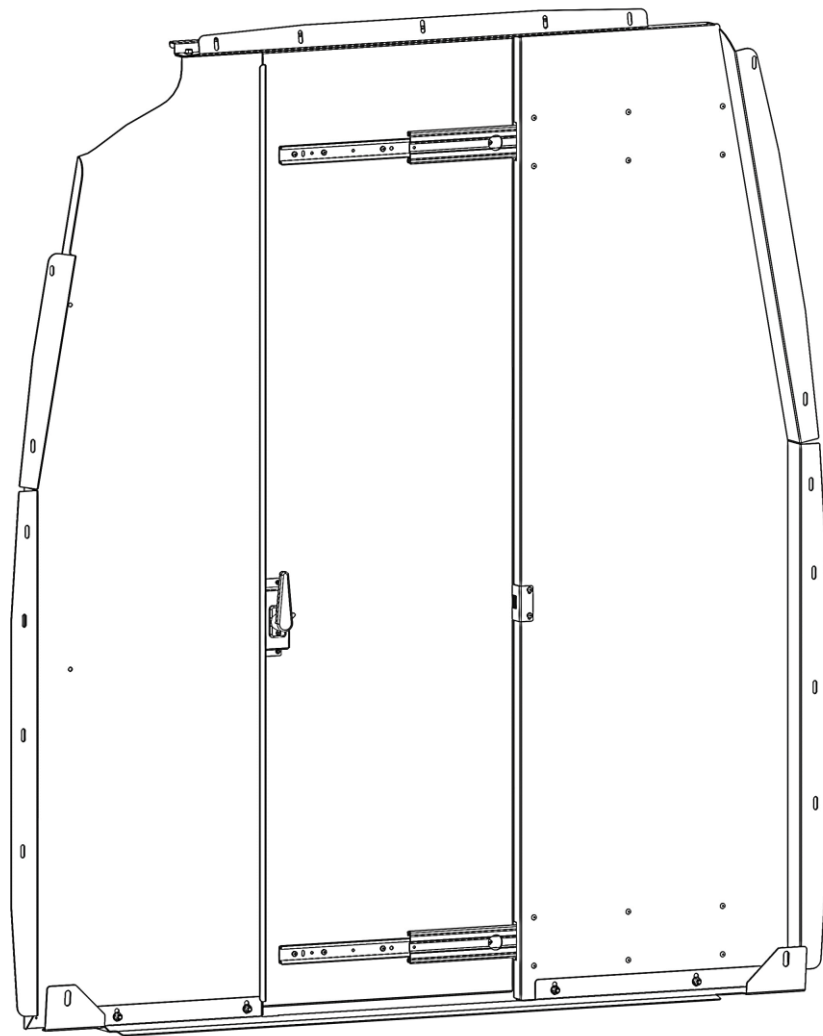

Holman
Rancho Cordova, CA 95742
800-343-7486
InstallationSupport@holman.com

PLEASE READ ALL INSTRUCTIONS AND WARNINGS PRIOR TO ASSEMBLING, INSTALLING, AND USING THIS PRODUCT.

Warning



Always check for wires, fuel tanks and lines, brake lines and other important vehicle functionality items prior to drilling and installing all products.

Tools Needed

5/16", 7/16" Socket and Wrench	5/16" Box Wrench
25/64" Drill Bit	Drill
5/16" Allen Hex Wrench	Plus Nut Installation Tool (P9902)*
#2 Phillips Head Screwdriver	Drill Stop

**Must be purchased seperately.*

Table of Contents

Parts 2

Hardware 3

Latch Assembly Parts 4

Step 1 – Install Door Guide to driver side Panel Assembly..... 5

Step 2 – Attach Floor Bracket..... 5

Step 3 – Attach Top Panel..... 6

Step 4 – Partition Installation Preparation..... 6



Step 5 – Install Partition 8

Step 6 – Install Lock..... 9

Before You Begin

- Read all instructions prior to assembling or installing any Holman product.
- **Always locate your installation locations prior to performing any work.**
- **ENSURE SAFETY WHILE INSTALLING OR DRILLING INTO VEHICLE.**
- **Plus Nut Installation Tool Kit P9902 is not included and must be purchased separately.**

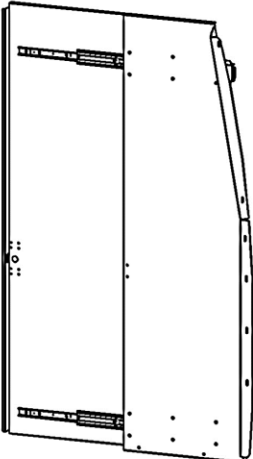
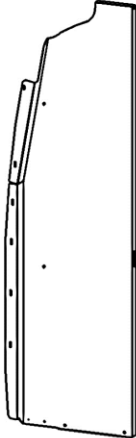
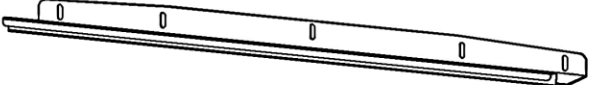

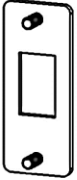
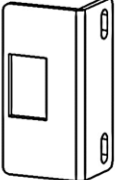

Parts

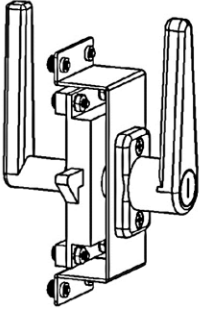
NO.	ITEM	PART NUMBER	DESCRIPTION	QTY.
1		406SD-10	SPRINTER HR-DS PANEL ASSEMBLY	1
2		406SD-00-003-R4	SPRINTER HR-PS PANEL	1
3		406SD-00-004-R5	SPRINTER HR-TOP PANEL	1
4		406SD-00-006-R3	PARTITION FLOOR BRACKET, SPRINTER	1
5		406SD-TH-008	DOOR GUIDE	1
6		406SD-00-013	PS STRIKER PLATE	1
7		406SD-00-014	DS STRIKER PLATE	1



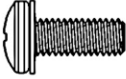
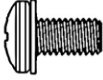

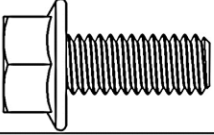
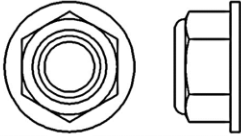
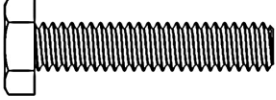

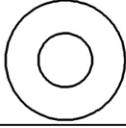
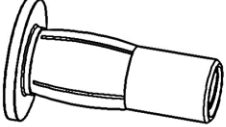

Parts (Continued)

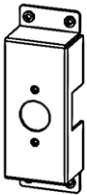
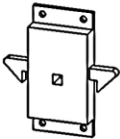
NO.	ITEM	PART NUMBER	DESCRIPTION	QTY.
8		406SD-LATCH ASSY-LOCKING- R3	LATCH ASSEMBLY	1
9		18-40601TH	HARDWARE	1

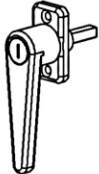
Hardware

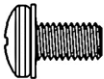
ITEM	HARDWARE TO SCALE	PART NUMBER	DESCRIPTION	QTY.
1			10-32 X 1/2" PAN HEAD SCREW, INTERNAL WASHER	2
2		0147641	10-32 X 3/8" PAN HEAD SCREW, INTERNAL WASHER	2
3			10-32 LOCK NUT, EXTERNAL WASHER	2
4		0155842	5/16"-18 X 3/4" FLANGED HEX HEAD	8
5		11104019	5/16-18 FLANGED NYLOCK NUT	8
6		13800	1/4"-20 x 1-1/4" HEX HEAD BOLT	17
7		33078	1/4" WASHER	17
8		1133618	1/4"-20 LOCK WASHER	18
9		920313726	1/4"-20 Plus Nut	17

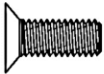
Latch Assembly Parts

NO.	ITEM	PART NUMBER	DESCRIPTION	QTY.
1		406SD-11	OUTER LOCK COVER	1
2		5696-DOOR LATCH	EBERHARD CENTER CASE	1
3		406SD-00-011	SPACER	2
4		LH-L-L303-CH-HANDLE	LOCKING HANDLE	1
5		BP I-8002 CH	INTERNAL HANDLE	1
6		0147641	10-32 X 3/8" INTERNAL TOOTH PAN HEAD SCREW	4
7		90403A831	10-32 X 3/4" INTERNAL TOOTH WASHER PAN HEAD SCREW	4
8		90471A355	10-32 X 1/2" FLAT HEAD SCREW	2
9		90675A195	10-32 EXTERNAL TOOTH LOCK NUT	4

Step 1 – Install Door Guide to Driver Side Panel Assembly

- Using two #10 x 1/2" pan head screws, secure the door guide to the driver side panel assembly.

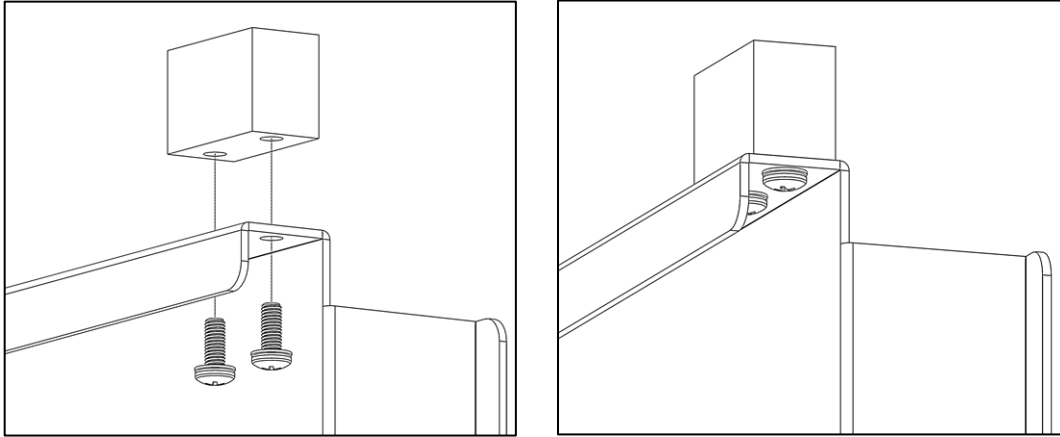

Step 2 – Attach Floor Bracket

- Set driver side panel assembly and passenger side panel flat next to each other and both on the floor bracket.

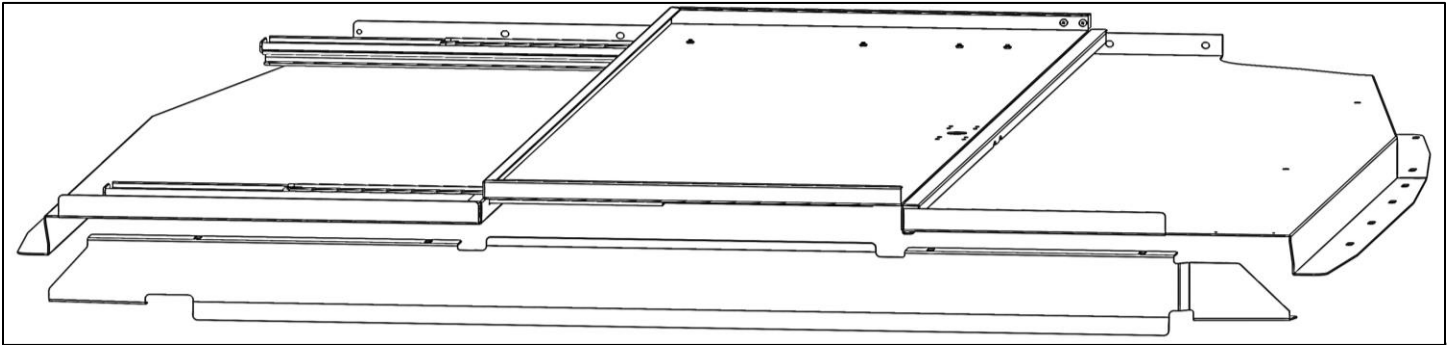

- Using four 5/16" x 3/4" flanged hex head bolts and four 5/16" flanged lock nuts attach floor bracket to the partition panels.
- Snug tighten but allow for movement.

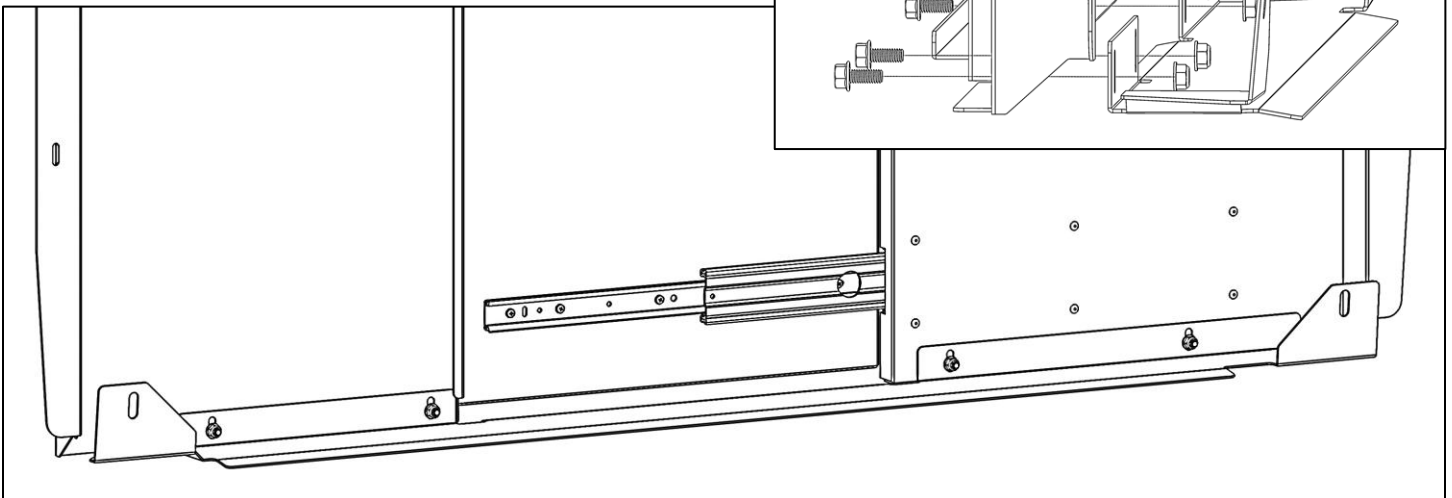
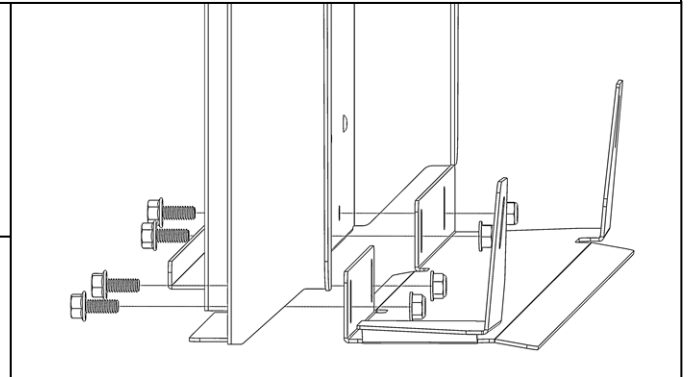

Step 3 – Attach Top Panel

- Using four 5/16" x 3/4" flanged hex head bolts and four 5/16" flanged lock nuts attach top panel to the partition panels. **Be sure door guide is inside top panel track.**
- Snug tighten but allow for movement.

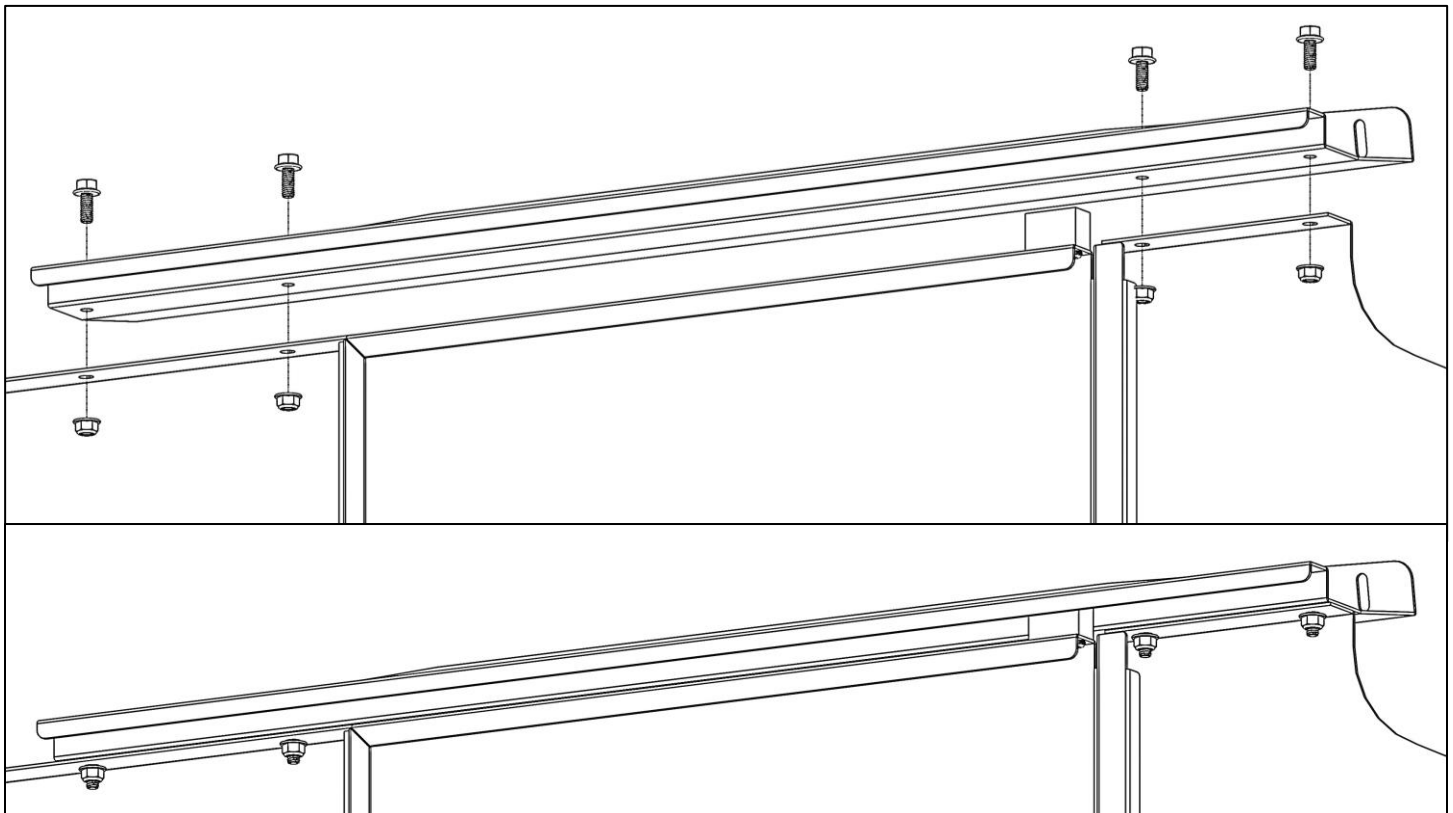
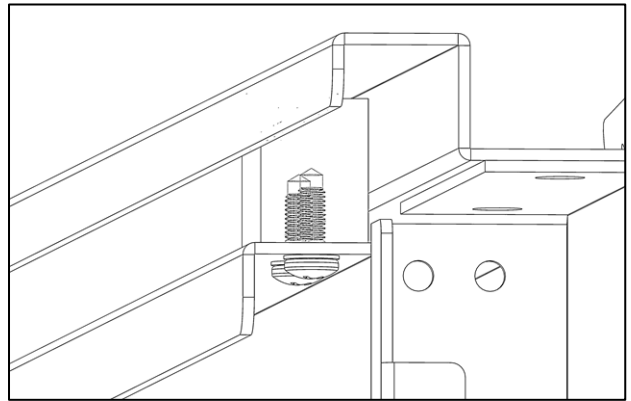

Step 4 – Partition Installation Preparation

D-Ring Removal

- Remove factory installed D-rings from behind driver side and passenger side seats.

Roof Support Preparation

- Press the assembled partition with wings firmly against the B-pillars and the top panel across the roof support of the van.
- Ensure the partition is square and aligned to your liking in relation to the van. Be sure to align the large slots in the floor bracket with the D-ring holes.

- Mark onto the B-pillar and roof support the location of all the slots and holes in the top and sides of the partition panels.

Ensure this is the location of where you want the partition to be installed.

- Set partition assembly aside.

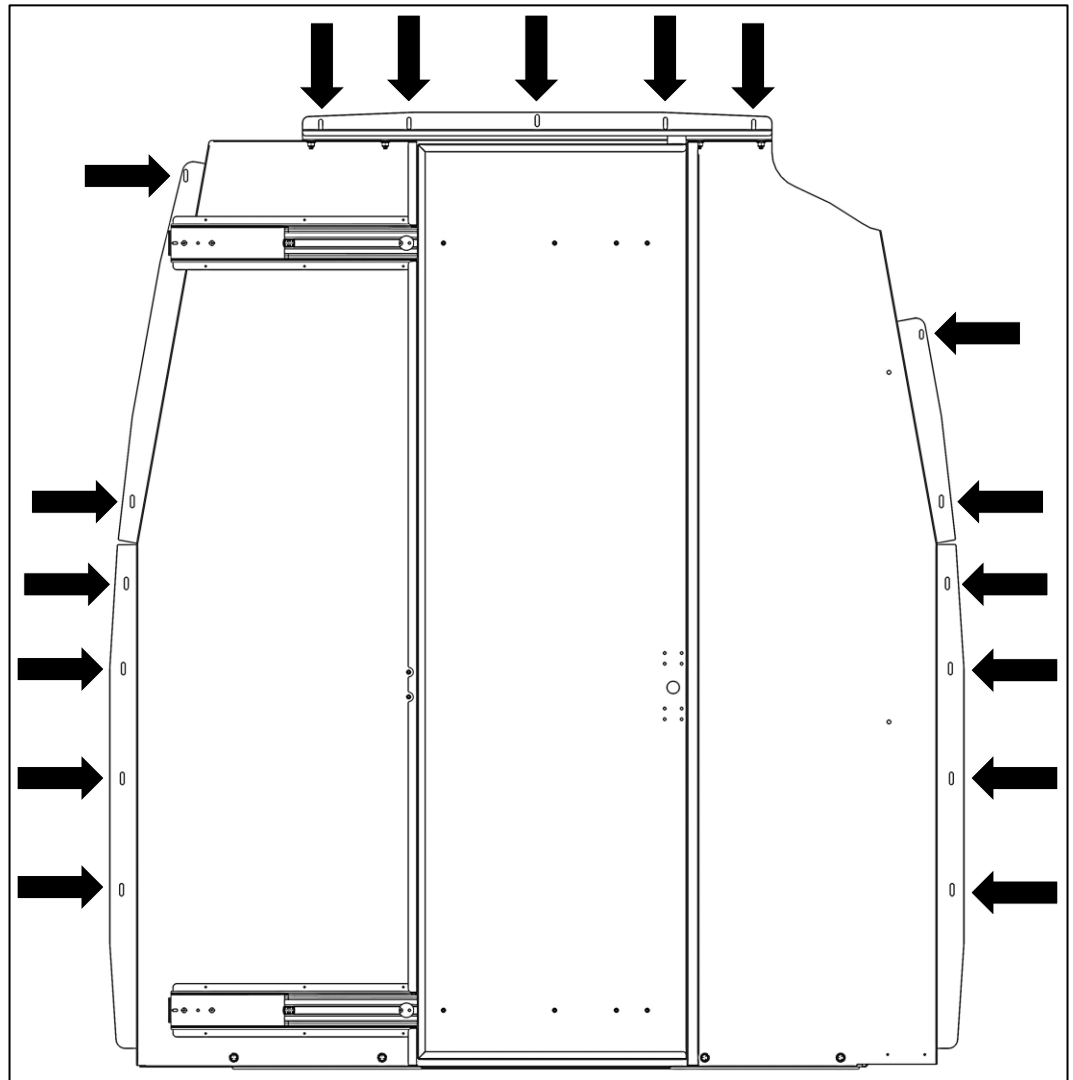

Installing Plus Nuts



DO NOT drill beyond depth of B-pillar or upper installation surface. When installing hardware through any installation surface, always ensure the area behind the installation surface is clear of electrical wiring, fuel tank or lines, or any vehicle safety features.

- At each marked location, drill hole using 25/64" drill bit and appropriate sized drill-bit stop collar. If 25/64" drill bit is not available, a 3/8" drill bit can be used, although it may be necessary to tap in plus nuts.
- Screw 1/4" x 2-1/4" hex head bolt through 1/4" flat washer and plus nut installation tool, and then into plus nut. Knurled end of plus nut tool must be directed away from bolt head and contacting plus nut.
- Insert plus nut into hole with plus nut tool attached.
- Using the 9/16" box wrench, hold the plus nut tool stationary and then tighten hex head bolt until plus nut is tightly gripping and does not spin when hex bolt is loosened.
- DO NOT overtighten plus nut.

- Using the 9/16" box wrench, hold the plus nut tool stationary to remove the 1/4" hex head bolt.

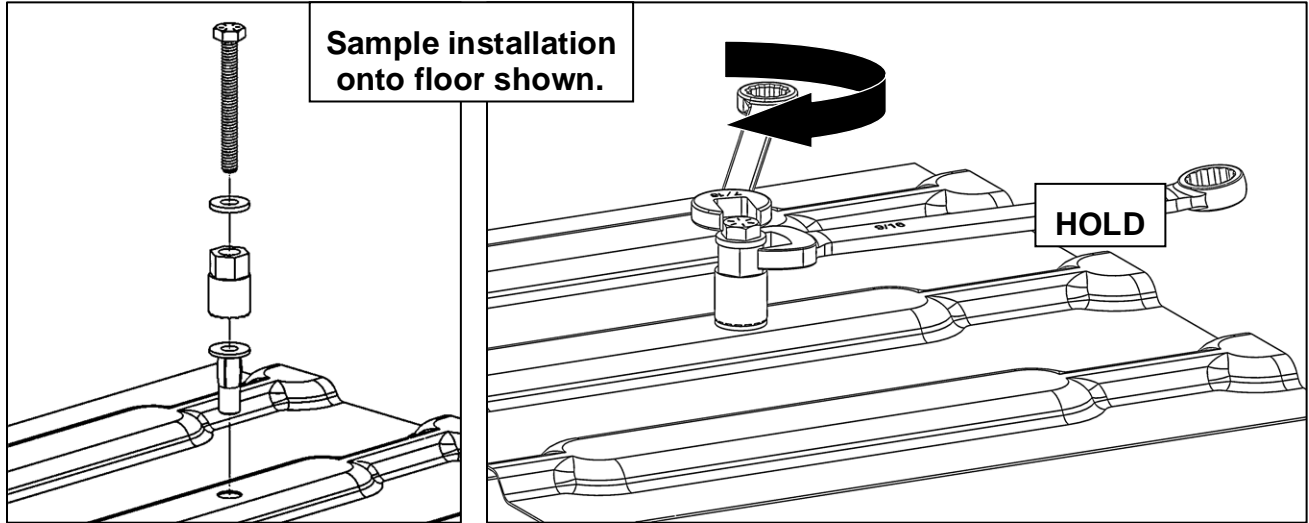

Step 5 – Install Partition

- Using 1/4" x 1-1/4" hex head bolts, 1/4" lock washers, and 1/4" flat washers, install partition to B-pillar and roof support.

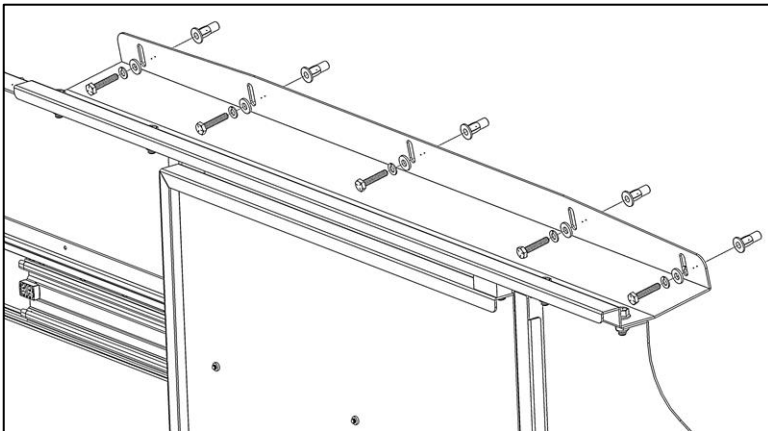

- Reinstall D-rings through the slots in floor bracket.

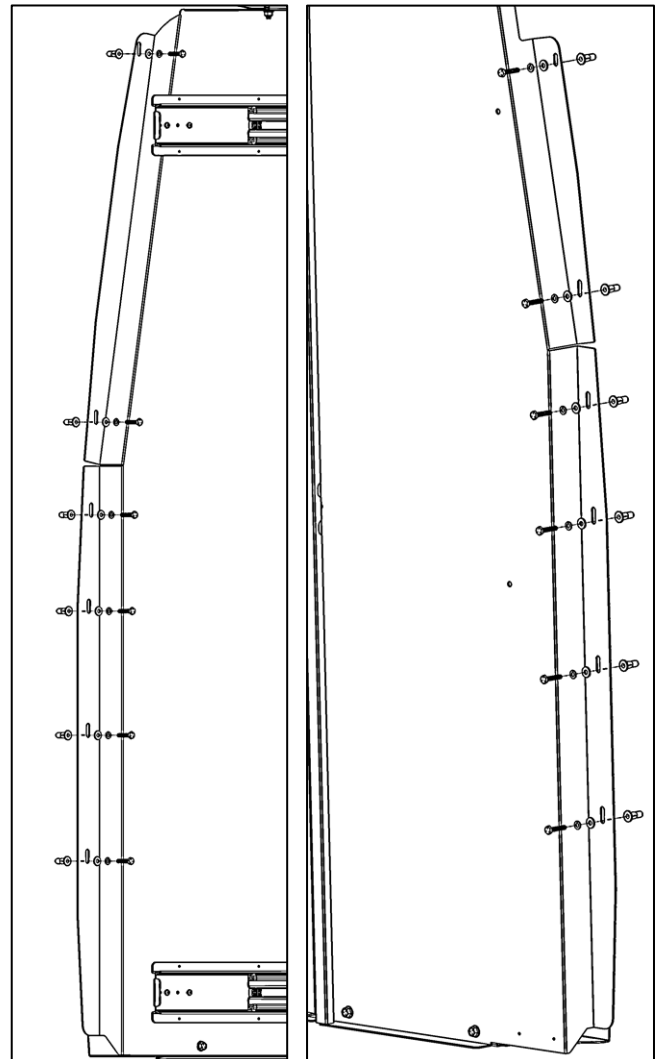

Step 6 – Install Lock

- Remove #10 screws, #10 internal washer nuts, and latch spacers from latch assembly.
- Using four #10 x 3/4" pan head screws, #10 internal washer nuts, and latch spacers, install the center case to the door as shown. **Be sure the center case is oriented as shown with the lock hasp pointed down and the latch spacers are between the partition and the inner lock assembly.**

- TIGHTEN.

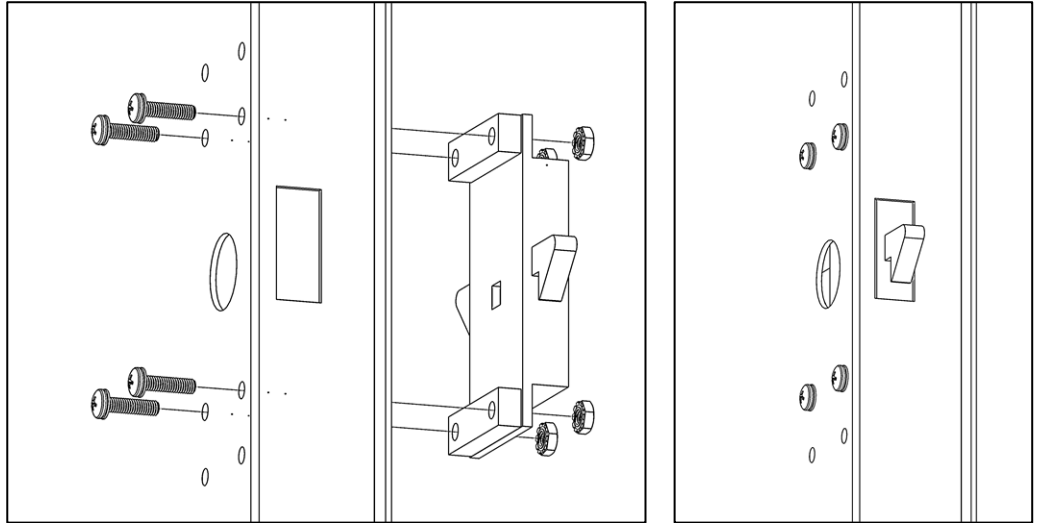

- Using four #10 x 3/8" pan head screws, install the outer lock cover to the door as shown.

- TIGHTEN.

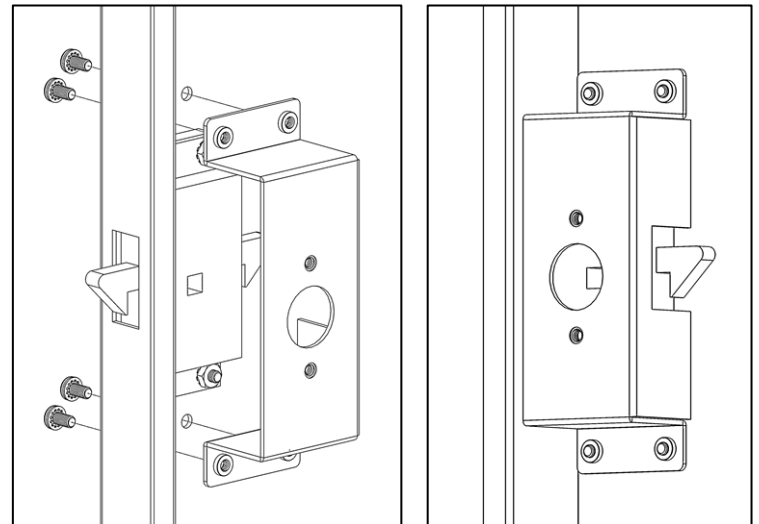

- Using two #10 x 3/8" flat head screws, install the outside locking handle to the lock cover.

- TIGHTEN.

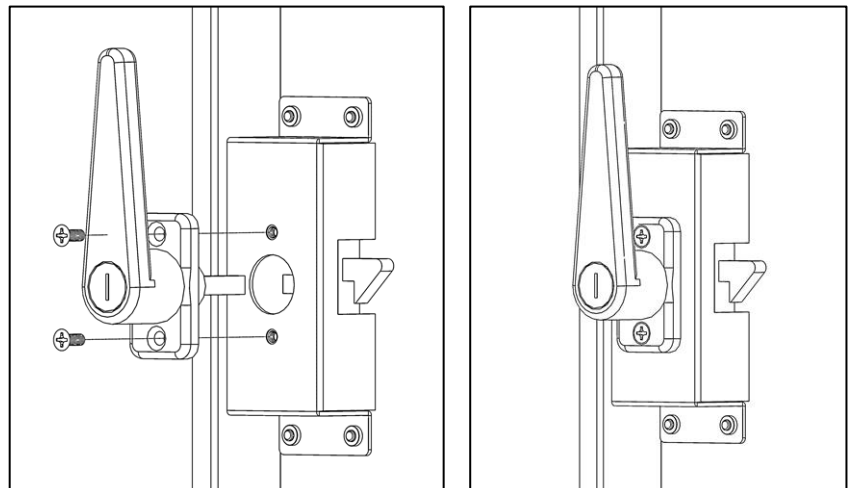

- Push the internal handle onto the square shaft and, using a 5/16" hex wrench, fasten the internal handle to the shaft.
- TIGHTEN.

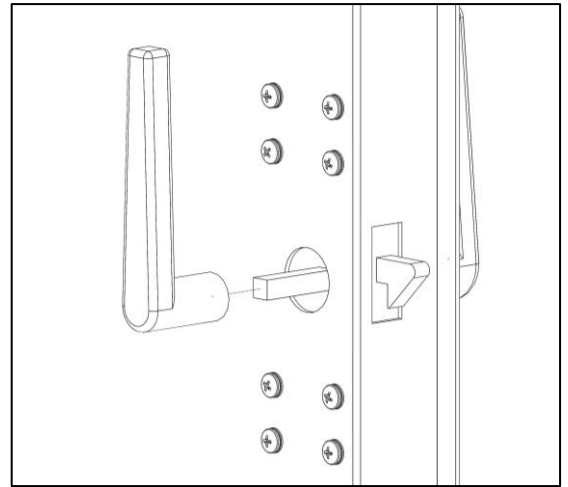

- Using two #10 external washer nuts, LOOSELY attach the passenger side striker plate to the passenger-side door jam.
- Adjust the striker plate up or down until the latch catches securely.
- TIGHTEN.

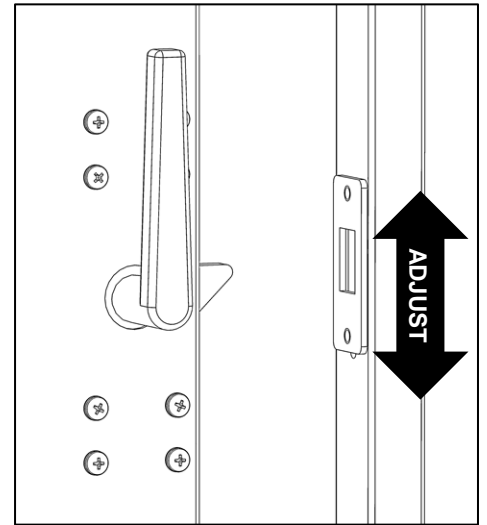
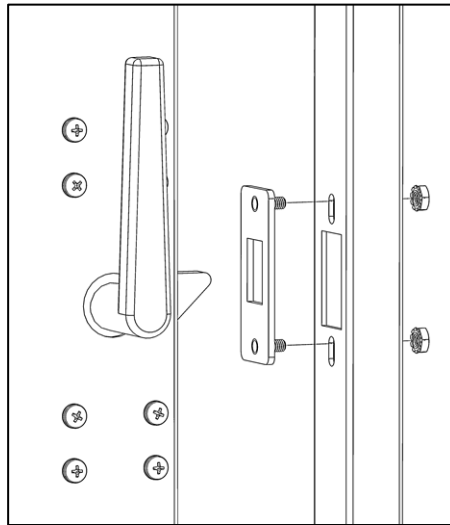

- Using two #10 X 3/8" pan head screws, LOOSELY attach the driver side striker plate to the driver-side door jam.
- Adjust the striker plate up or down until the latch catches securely.
- TIGHTEN.

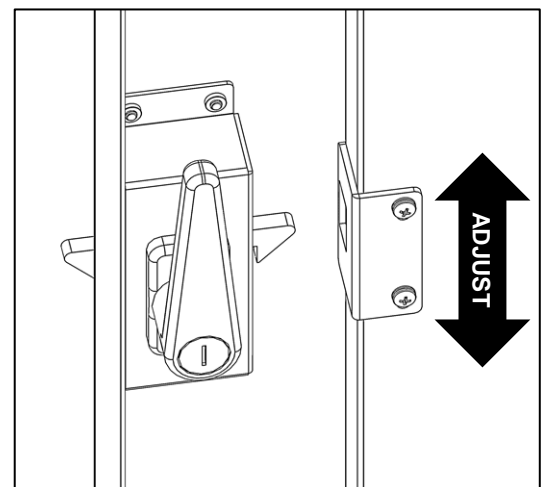
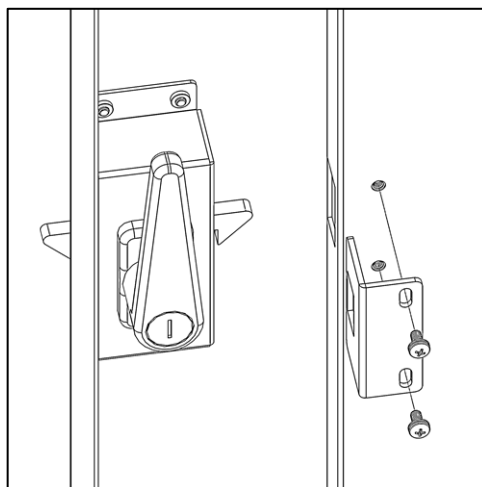

GO BACK AND TIGHTEN ALL HARDWARE.
INSTALLATION AND ASSEMBLY ARE COMPLETE.