

Holman

Instruction Guide

40640-40641-40642-40645

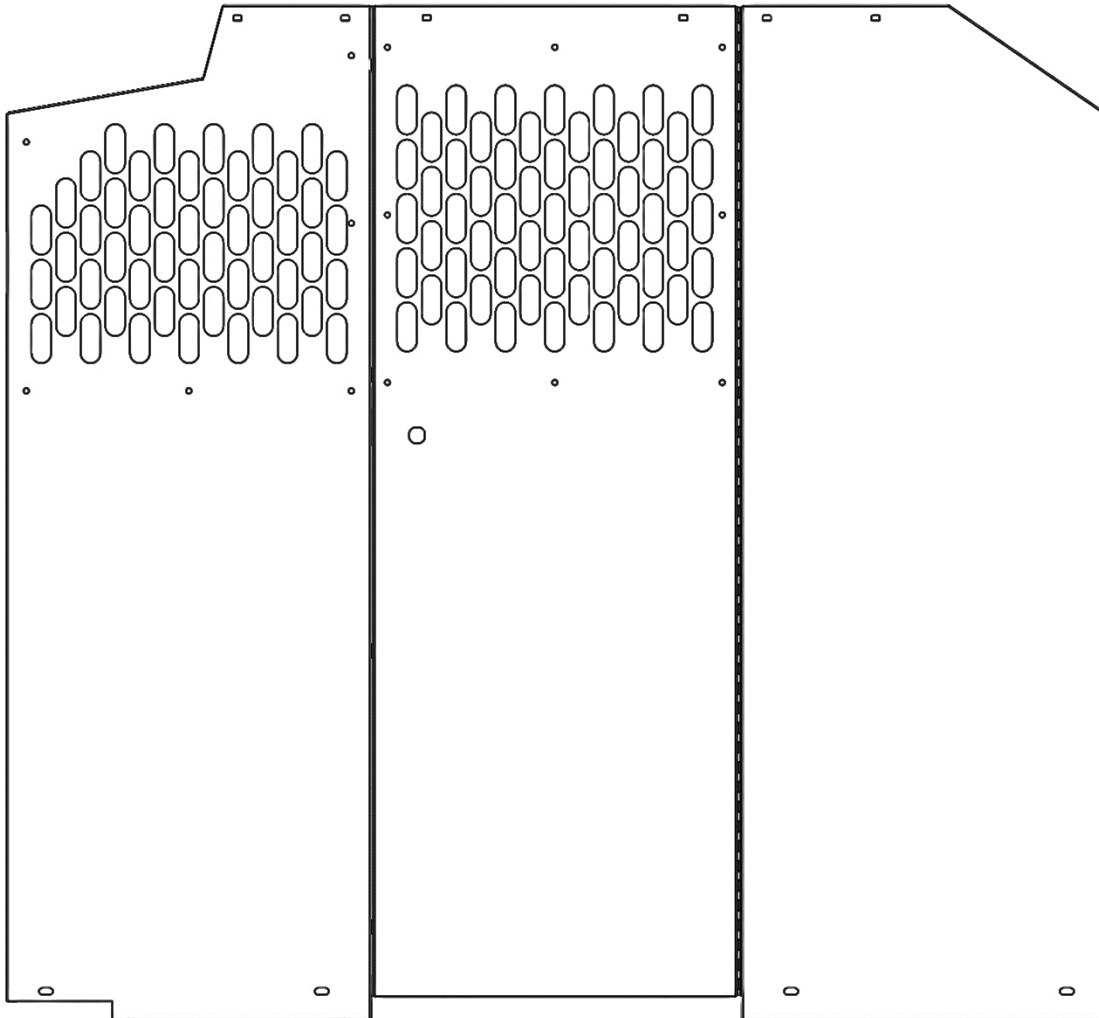

Holman
Rancho Cordova, CA 95742
800-343-7486

InstallationSupport@Holman.com

PLEASE READ ALL INSTRUCTIONS AND WARNINGS PRIOR TO ASSEMBLING, INSTALLING, AND USING THIS PRODUCT.

Warning



Always check for wires, fuel tanks and lines, brake lines and other important vehicle functionality items prior to drilling and installing all products.

Tools Needed

3/8" Wrench and Socket	7/16" Box Wrench
------------------------	------------------

Table of Contents

Tools Needed	1
Before You Begin	1
Parts	1
Hardware	2
Join Panels	3

Before You Begin

- Read all instructions before installing any Holman product.
- Use vehicle specific wing kit to complete installation.
- Images shown are for a 40640. All instructions are the same for 40640, 40641, 40642, and 40645.

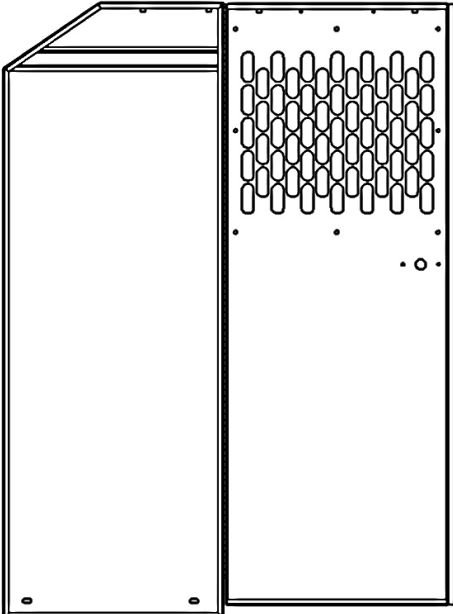

Parts

ITEM NO.	ITEM	PART NUMBER	DESCRIPTION	QTY
1		40640, 406642: 40640-10 OR 40641:40641-10 OR 40645:100753	STANDARD PARTITION DOOR ASSEMBLY OR SOLID PARTITION DOOR ASSEMBLY OR STANDARD PARTITION DOOR ASSEMBLY WITH DOG DOOR	1

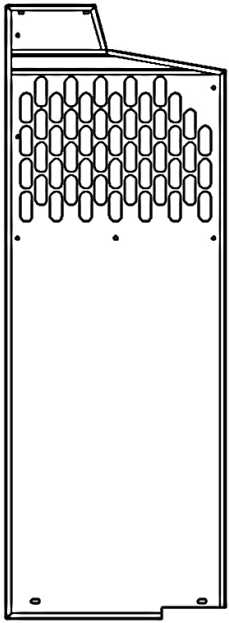
Parts (Continued)

ITEM NO.	ITEM	PART NUMBER	DESCRIPTION	QTY
2		40640, 40642, 40645:40640-20 OR 40641:40641-20	STANDARD PARTITION SIDE PANEL OR SOLID PARTITION SIDE PANEL	1
3		18-40600	STANDARD PARTITION-HARDWARE	1

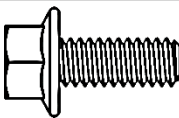
Hardware

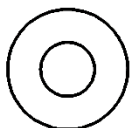
ITEM	HARDWARE TO SCALE	PART NUMBER	DESCRIPTION	QTY.
1		11106180	1/4"-20 X 5/8" FLANGED HEX HEAD	4
2			1/4-20 FLANGED NYLON INSERT NUT	4
3		11541082	1/4" FLAT WASHER	8

Join Panels

- Place both partition door assembly and partition side panel flat on the ground or table. **Be sure to have the flanges facing upward so you can access the bolt holes.**
- Bolt together using a 1/4" x 5/8" flanged hex bolt, two 1/4" flat washers, and a 1/4" flanged lock nut. Be sure to put the two flat washers in between the door assembly and side panel. This ensures correct spacing.

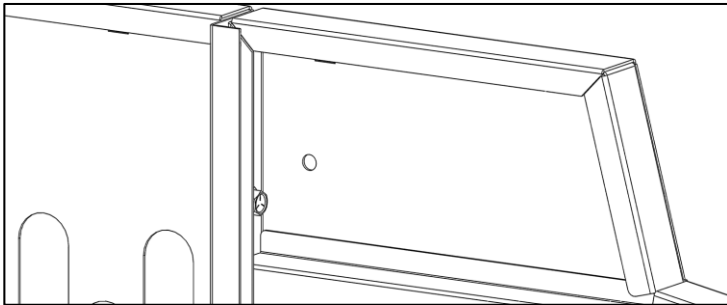
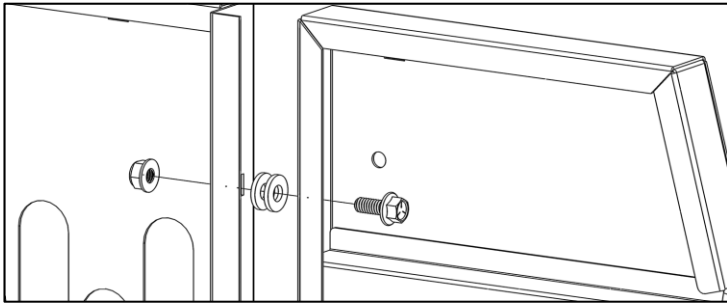

- Snug tighten but allow movement.
- Repeat 3 more times as shown.

NOTE: It may be helpful to leave bolts snug tight but allowing for movement until partition is installed into vehicle.

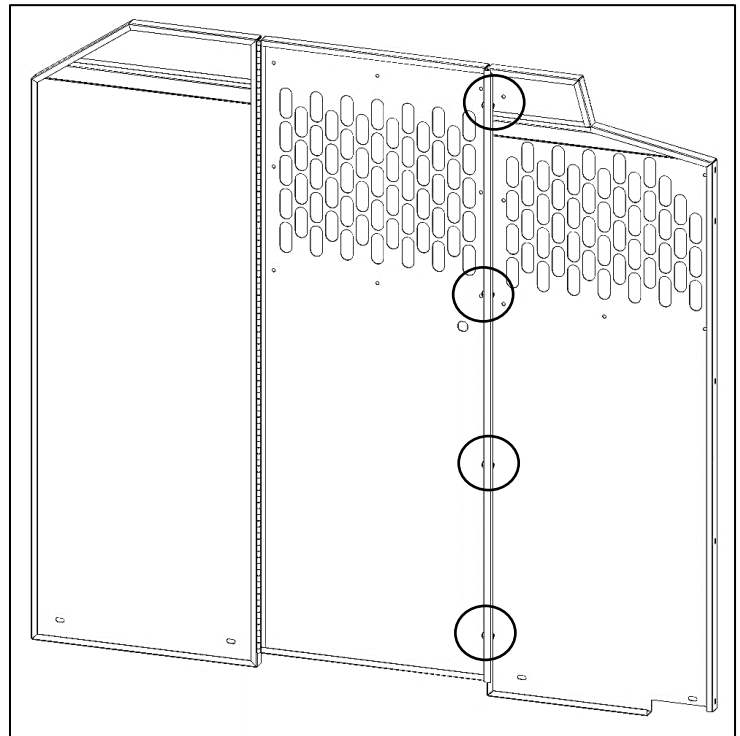
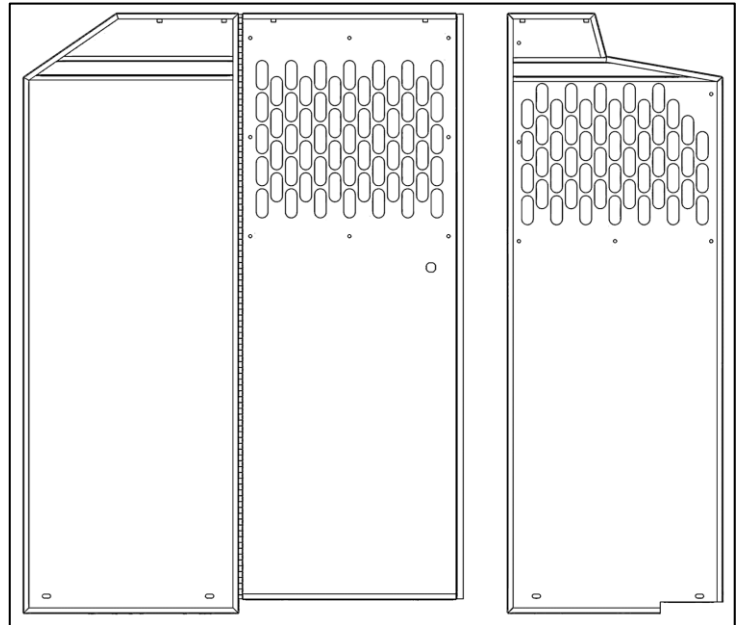

FOLLOW INSTRUCTIONS OF DESIRED WING KIT TO INSTALL INTO VEHICLE.

ASSEMBLY IS COMPLETE.