

Holman

Installation Guide 4064P

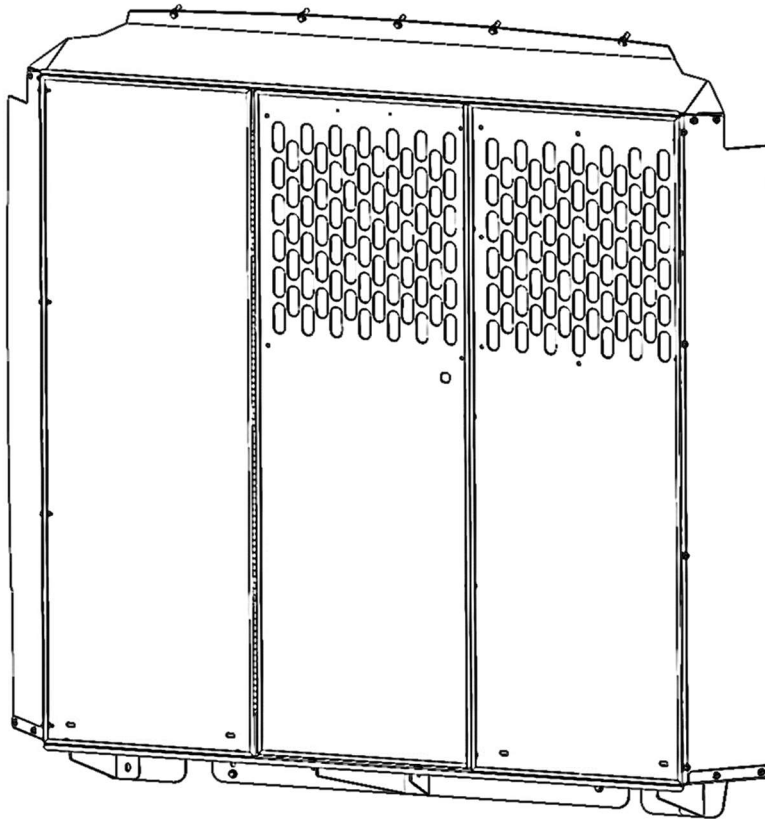

Holman
Rancho Cordova, CA 95742
800-343-7486

InstallationSupport@Holman.com

PLEASE READ ALL INSTRUCTIONS AND WARNINGS PRIOR TO ASSEMBLING, INSTALLING, AND USING THIS PRODUCT.

Warning



Always check for wires, fuel tanks and lines, brake lines and other important vehicle functionality items prior to drilling and installing all products.

Tools Needed

3/8" Wrench and Socket	7/16" Wrench and Socket
9/16" Wench and Socket	Plus Nut Installation Tool (P9902)*
25/64" Drill Bit	Drill Stop
Drill	

** Sold Separately.*

Table of Contents

Parts List 2

Hardware List 3

Step 1 – Install Top Wing 3

Step 2 – Install Floor Mount..... 4

Step 3 – Install Floor Supports 5



Step 4 – Install Wings 6

Step 5 – Install Partition 7

Before You Begin

- Read all instructions prior to installing or assembling any Holman product.
- **HAVE TALL PARTITION (40651 OR 40652) ASSEMBLED BEFORE INSTALLING THIS WING KIT.**
- **ENSURE SAFETY WHILE INSTALLING OR DRILLING INTO VEHICLE.**
- **Plus Nut Installation Tool Kit (P9902) is not included and must be purchased separately.**

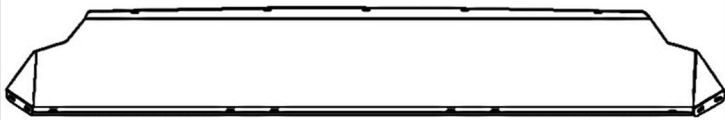
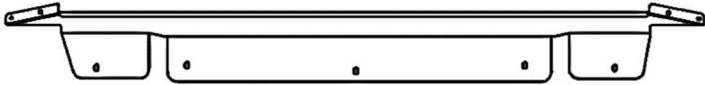
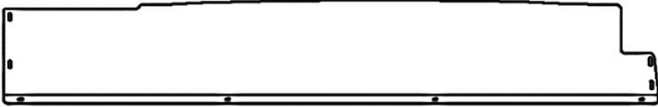
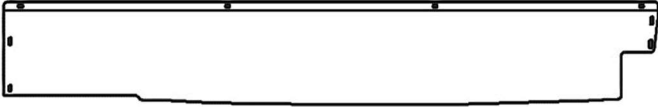

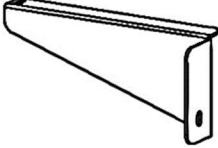
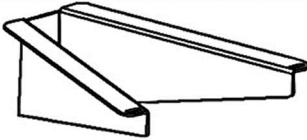
Parts

NO.	ITEM	PART NUMBER	DESCRIPTION	QTY.
1		4064P-00-001	ProMaster Top Panel	1
2		4064P-00-002	ProMaster Partition Bottom Panel	1
3		4064P-00-003	Promaster Partition Driver Wing	1
4		Mirror4064P-00-003	Promaster Partition Passenger Wing	1
5		4064P-00-005	Outside Support - PS	1
6		Mirror4064P-00-005	Outside Support - DS	1
7		4064P-00-006	Middle Support	1
8		18-4064P	4064P-Hardware Kit	1

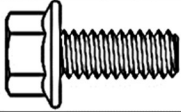
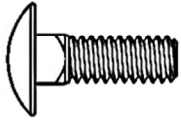
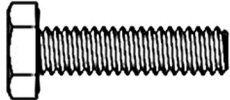
Hardware

ITEM	HARDWARE TO SCALE	PART NUMBER	DESCRIPTION	QTY.
1		11126953	1/4"-20 X 5/8" FLANGED HEX HEAD	26
2		21801	1/4"-20 X 3/4" CARRIAGE BOLT	2
3		13005	1/4-20 X 1" HEX HEAD BOLT	8

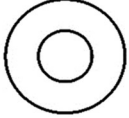
Hardware Cont.

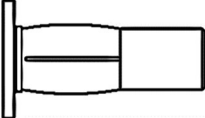
ITEM	HARDWARE TO SCALE	PART NUMBER	DESCRIPTION	QTY.
4		33618	1/4" LOCK WASHER	8
5		33078	1/4" FLAT WASHER	8
6		0167030	1/4"-20 FLANGED LOCK NUT	28
7		920313726	1/4"-20 Plus Nut	8

Step 1 – Install Top Wing

- Hold top wing against headliner along the B pillar roof support.
- Using the top wing as a template, mark on the headliner through the mounting slots. Check that these align with five of the factory holes behind the headliner.
- Make a one-inch vertical cut on headliner both sides of the mark made previously on the headliner and fold down material that you cut to expose factory holes in support beam.

Always ensure, when installing hardware through any installation surface, the area behind the installation surface is clear of electrical wiring or vehicle safety features.

- **It is not advised to cut entire width of headliner to access factory holes.**
- Use 25/64" drill bit and appropriate sized drill-bit stop collar to open up exposed holes. If 25/64" drill bit is not available, a 3/8" drill bit can be used, although it may be necessary to tap in the plus nuts.
- Insert 1/4" x 2-1/4" hex head bolt through 1/4" flat washer and plus nut installation tool, and then screw bolt into plus nut. Knurled end of plus nut tool must be directed away from bolt head and contacting plus nut.
- Insert plus nut into hole with plus nut tool attached.
- Using the 9/16" box wrench, hold the plus nut tool stationary and then tighten hex head bolt until plus nut is tightly gripping and does not spin when hex bolt is loosened.
- **DO NOT** overtighten plus nut.

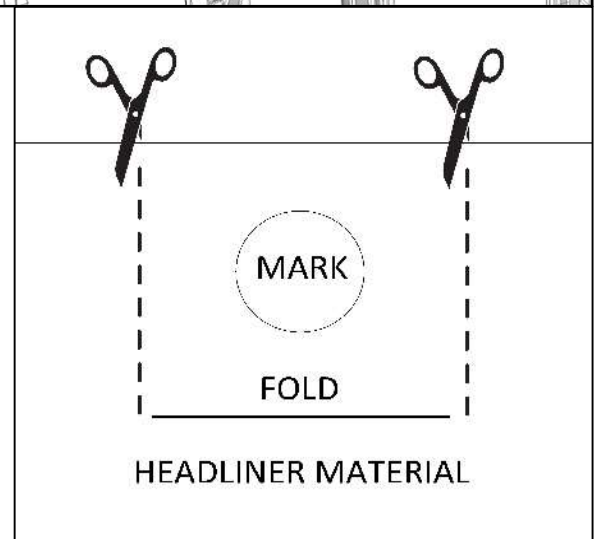
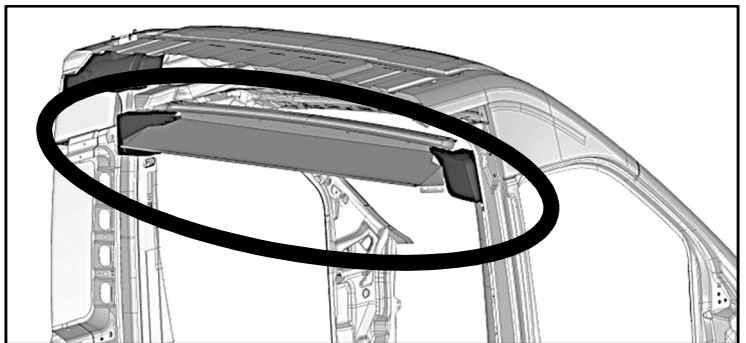

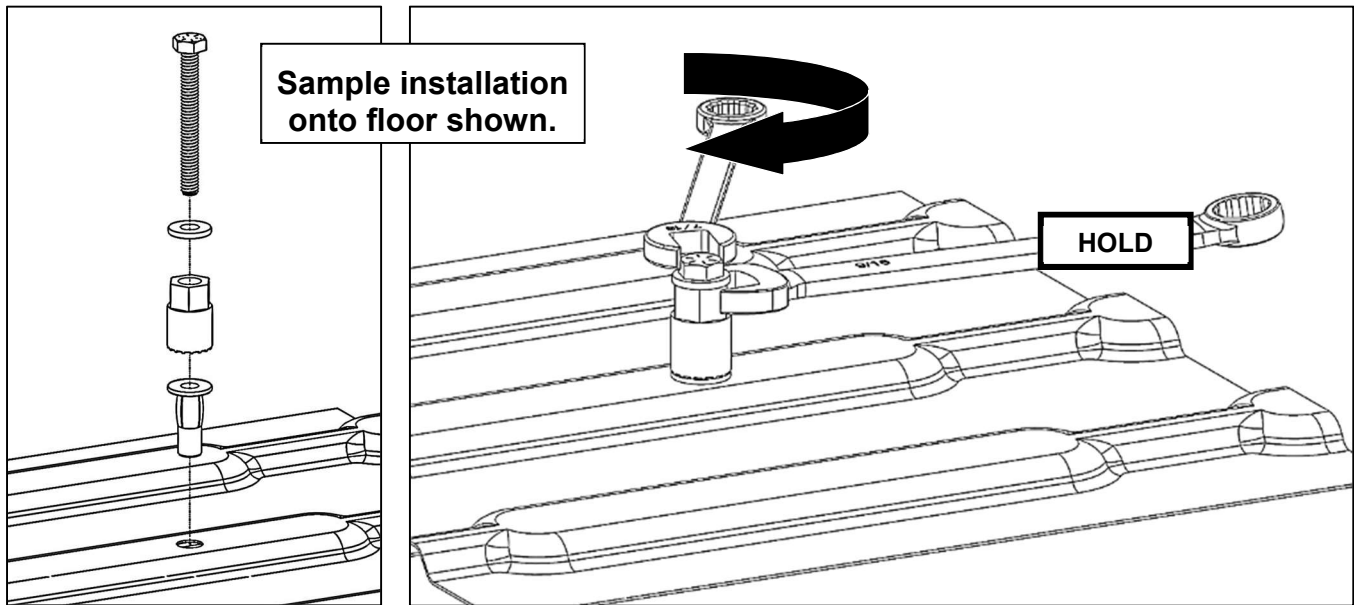

- Using the 9/16" box wrench, hold the plus nut tool stationary to remove the 1/4" hex head bolt.
- Using 1/4" x 1" hex head bolts, 1/4" lock washers and 1/4" flat washers bolt top wing to the five plus nuts previously installed.
- Snug tighten, but allow movement.

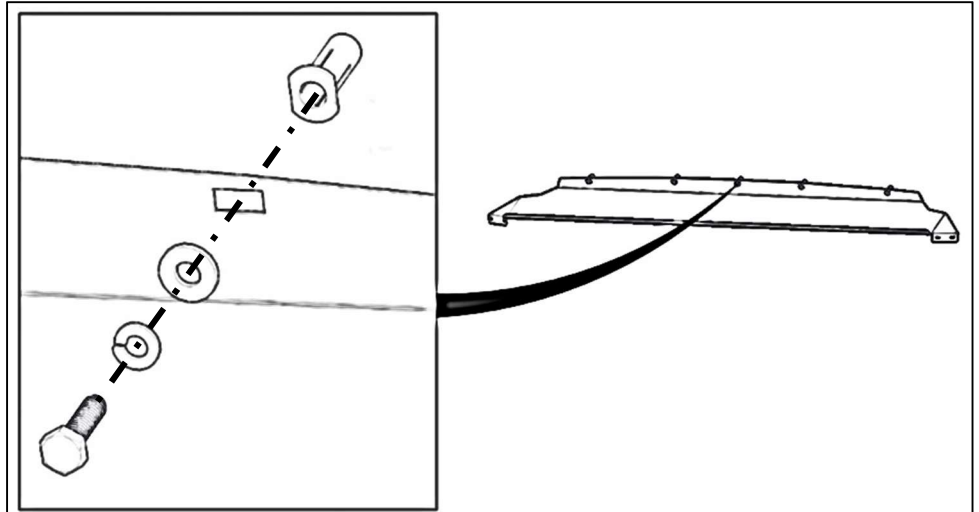

Step 2 – Install Floor Mount

- Remove D-Rings below seats on floor pedestal.
- Align the outside holes on the bottom wing with the D-Ring holes. Press wing against floor pedestal.
- Using the bottom wing as a template, mark through the three middle slots of the bottom wing onto the floor pedestal.
- Remove bottom wing.
- Use 25/64" drill and drill bit stop collar to drill marked locations.
- **Always ensure, when installing hardware through any installation surface, the area behind the installation surface is clear of electrical wiring or vehicle safety features.**
- Install three plus nuts in previously drilled holes.

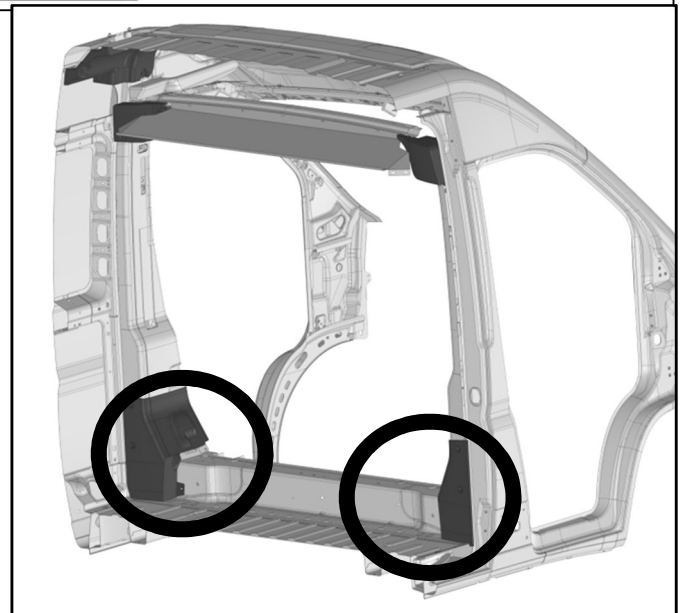

- Using 1/4" x 1" hex head bolts, 1/4" lock washers and 1/4" flat washers bolt bottom wing to the two outside plus nuts previously installed.
- Snug tighten, but allow movement.

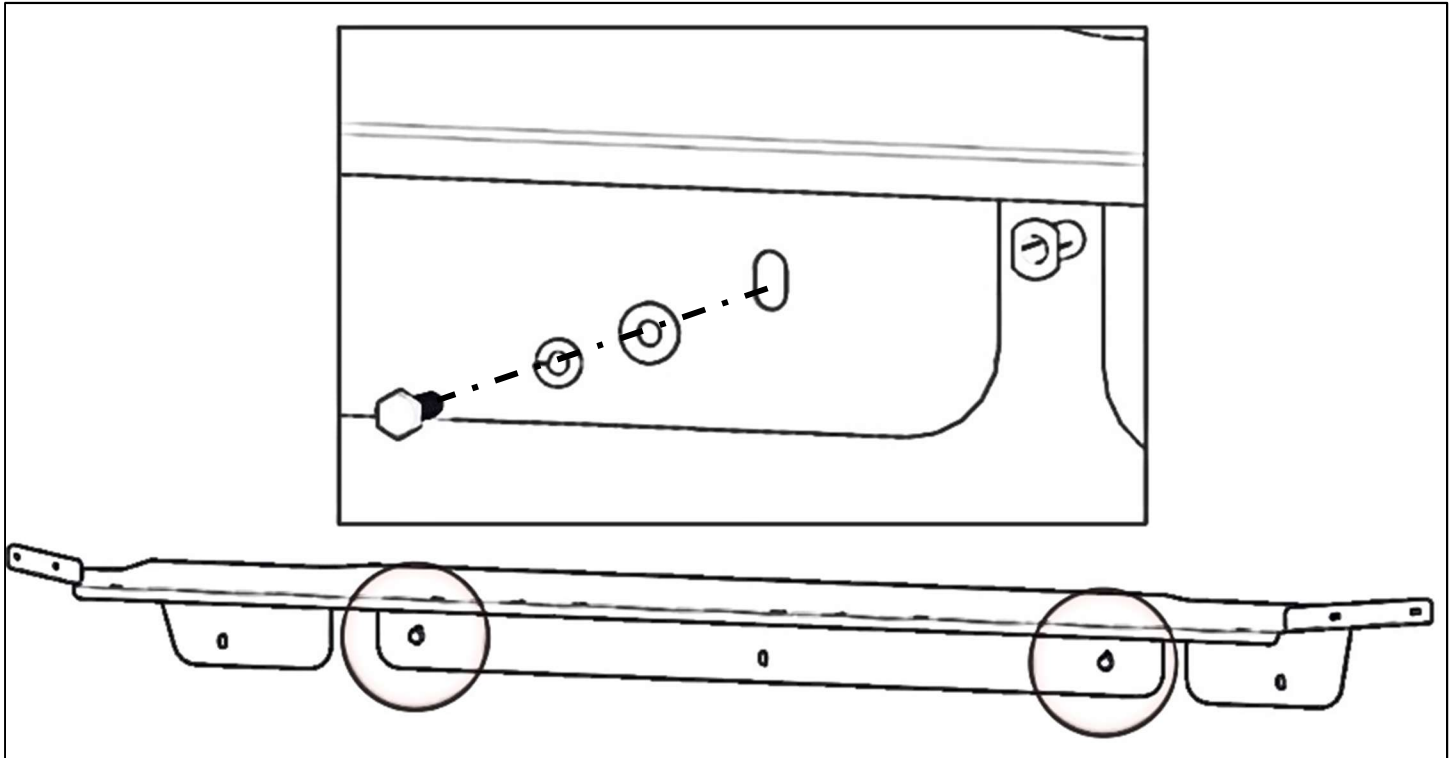

Step 3 – Install Floor Supports

- Place outside support driver side (DS), middle support and outside support passenger side (PS) under bottom wing.
- Using previously removed D-Ring, bolt outside support DS to the bottom wing. Repeat for the opposite outside support PS.

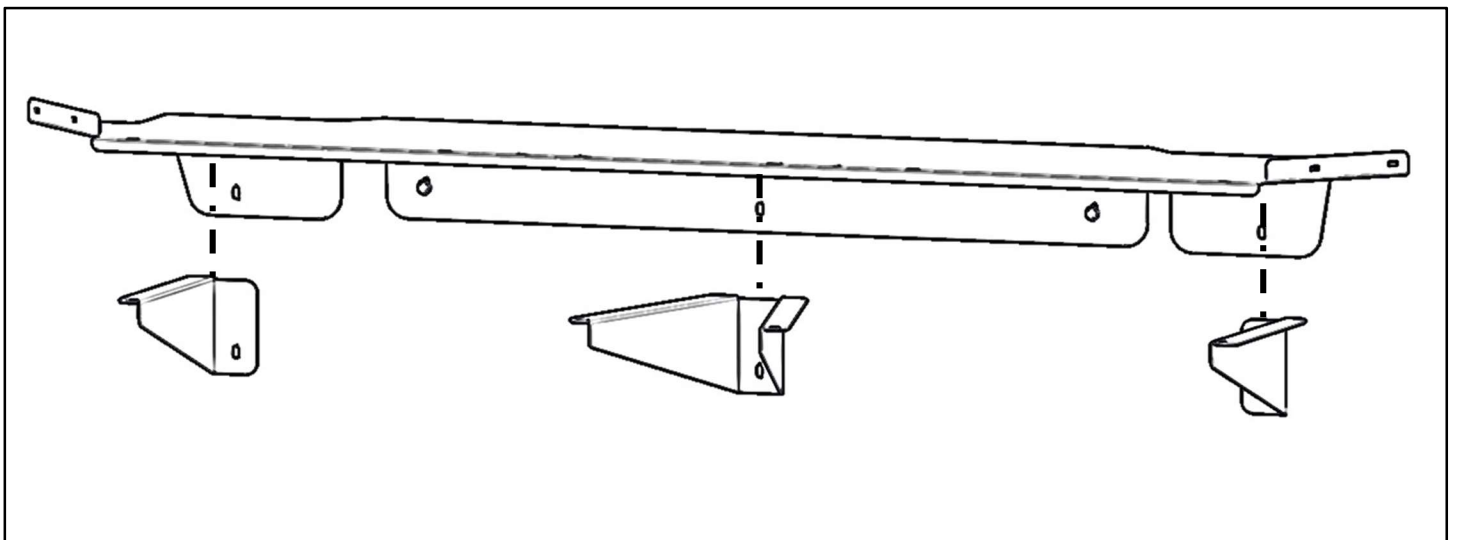

- Using 1/4" x 1" hex head bolts, 1/4" lock washers and 1/4" flat washers, bolt through the center slot of the bottom wing and the middle support into the center plus nut.
- Using two 1/4" x 3/4" carriage bolts and two 1/4" flanged lock nuts, bolt middle support to bottom wing out on the edge of platform.
- **At this time, only attach the middle support to the bottom wing.**
- Snug tighten, but allow movement.

Step 4 – Install Wings

- Using two 1/4" x 5/8" flanged hex head bolts and two flanged lock nuts in each corner attach side wings to both top and bottom wings.
- Snug tighten, but allow movement.

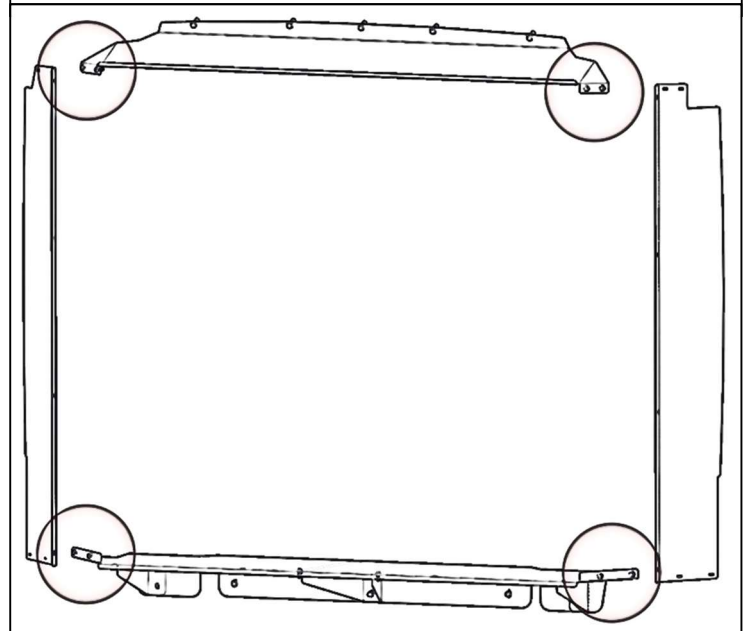
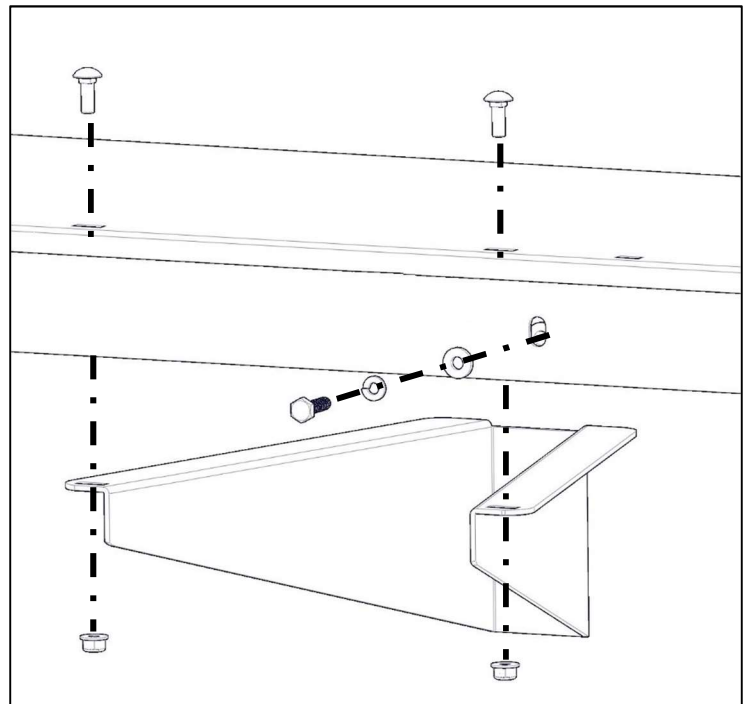
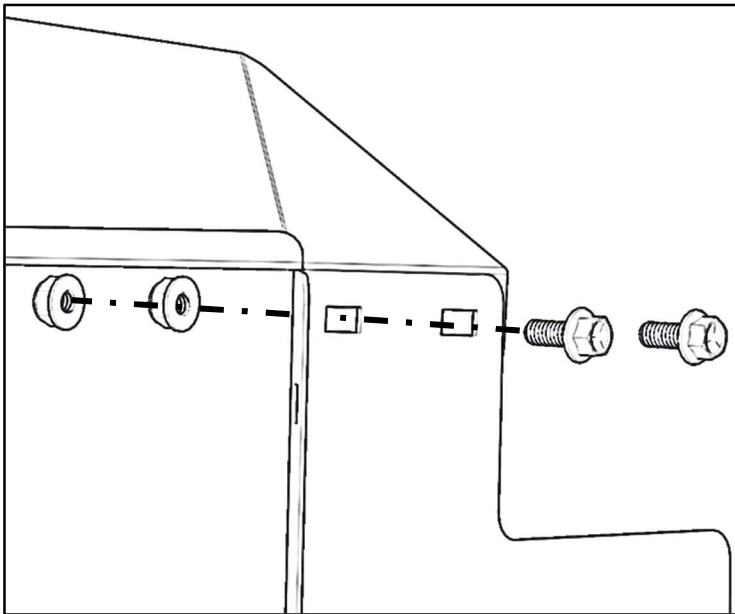

Step 5 – Install Partition

- Insert tall partition (40650 Series) assembly into van. **Be sure to have the flanges towards the rear of the van.**
- Using 1/4" flanged hex head bolts and 1/4" flanged lock nuts, bolt top and sides of partition to top and side wings.

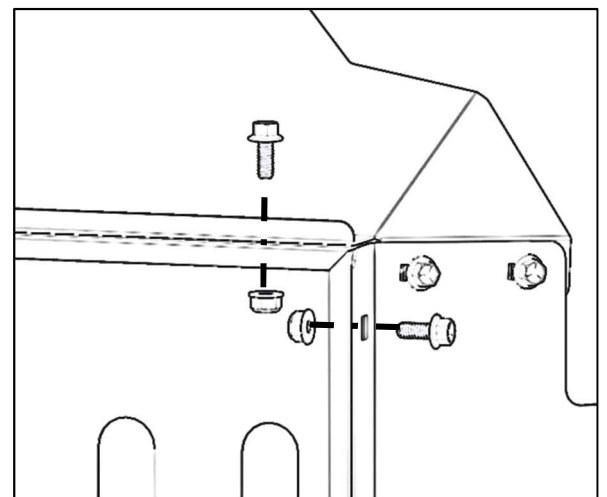

- Be sure to bolt through the supports installed in step 3 along the bottom of the partition.
- If using the pass through door, **DO NOT** bolt through middle panel of the partition.
- Snug tighten, but allow movement.

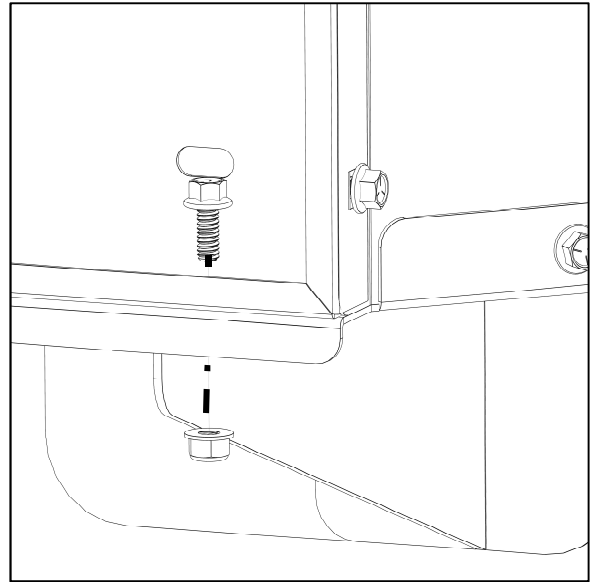

SQUARE AND ALIGN PARTITION TO YOUR LIKING.
GO BACK AND TIGHTEN ALL HARDWARE.

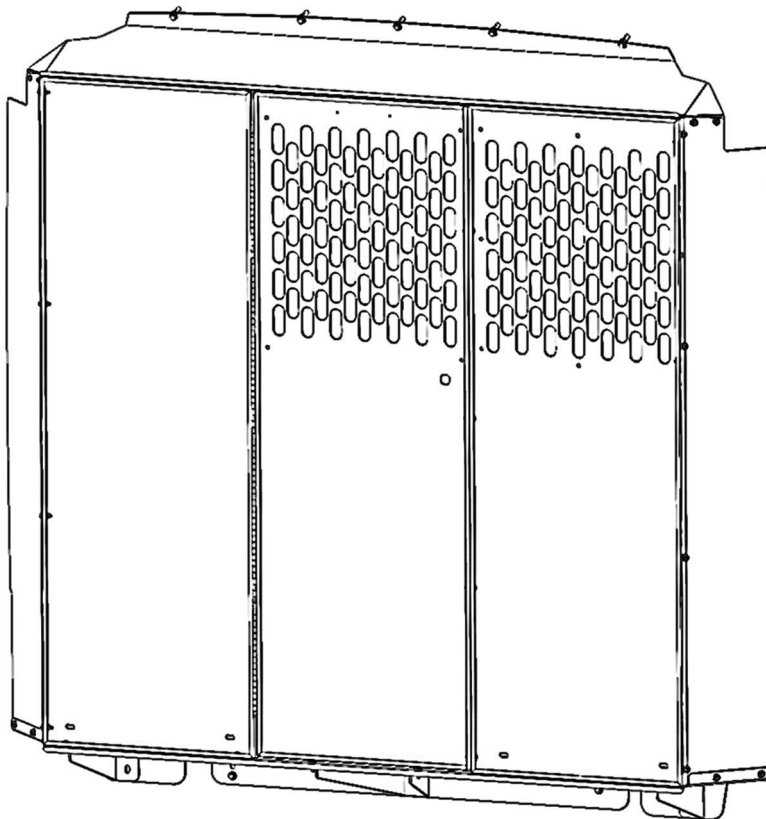

INSTALLATION IS COMPLETE.