

Holman

Instruction Guide 40669TH

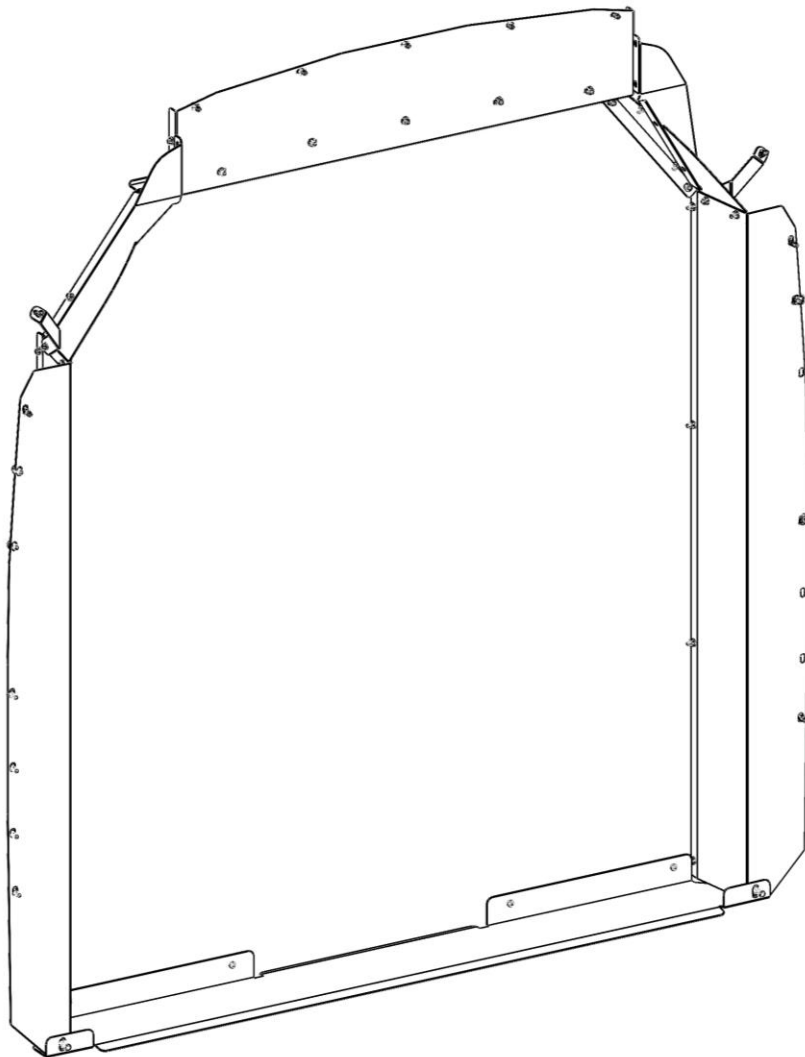

Holman
Rancho Cordova, CA 95742
800-343-7486

InstallationSupport@Holman.com

PLEASE READ ALL INSTRUCTIONS AND WARNINGS PRIOR TO ASSEMBLING, INSTALLING, AND USING THIS PRODUCT.

Warning



Always check for wires, fuel tanks and lines, air bags, brake lines, and other important vehicle functionality items prior to drilling and installing all products.

Tools Needed

7/16", 1/2" Sockets and Wrench	7/16", 9/16" Box Wrenches
10mm, 5/8" Socket	10mm Hex Driver Bit
Drill	25/64" Drill Bit
Plus Nut Installation Tool (P9902)*	Drill Bit Stop Collar

* Sold Separately.

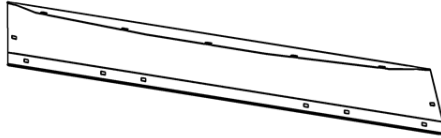
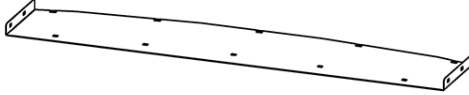
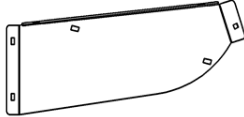
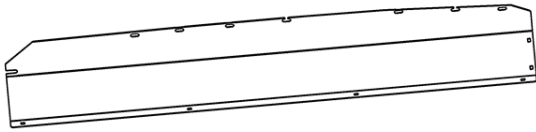



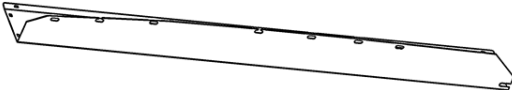

Table of Contents

Parts List.....	1
Hardware.....	2
Step 1 – Attach Side Wings.....	4
Step 2 – Attach Top Panel.....	4
Step 3 – Attach Corner Panels.....	5
Step 4 – Attach Corner Brackets.....	5
Step 5 – Attach Corner Wing Panels.....	6
Step 6 – Attach Top Wing.....	7
Step 7 – Attach Bottom Plate.....	7
Step 8 – Remove Factory Installed D-Rings.....	7
Step 9 – Install Driver’s Side Wing to “B” Pillar.....	8
U-Clips.....	8
Plus Nuts.....	9
Step 10 – Install Passenger Wing to “B” Pillar.....	10
Step 12 – Install Top Wing to “B” Pillar.....	11
Step 13 – Install Wings to D-ring Holes.....	12

Before You Begin

- Read all instructions prior to installing any Holman product.
- **Be sure to have a tall partition (40660, 40661, 40662, or 40665) assembled and ready to be installed.**
- **Plus Nut Installation Kit (P9902) does not come included and must be purchased separately.**



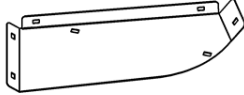
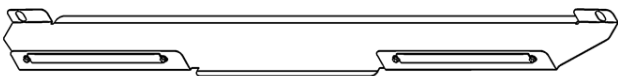

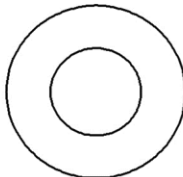
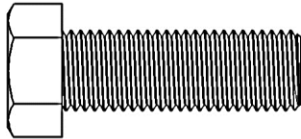

Parts List

NO.	ITEM	PART NUMBER	DESCRIPTION	QTY.
1		100769	TRANSIT HR TOP PANEL	1
2		100795	TRANSIT HIGH-ROOF TOP PANEL	1
3		100767	TRANSIT MR CORNER PANEL PS	1
4		406TH-10-001	TRANSIT MR PS WING	1
5		406TH-10-004	TRANSIT MR CORNER BRACKET RH PS	1
6		100765	TRANSIT HIGH-ROOF CORNER PANEL-PS	1
7		100766	Transit High-Roof Corner Panel-DS	1
8		406TH-10-001-MIRROR	TRANSIT MR DS WING	1
9		406TH-10-004-MIRROR	TRANSIT MR CORNER BRACKET LH DS	1
10		100768	Transit Mid-Roof Corner Panel DS	1
11		101240	TRANSIT SILL PLATE	1
12		18-100759	TRANSIT HR-HARDWARE	1

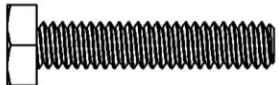
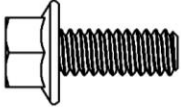
Hardware

ITEM	HARDWARE TO SCALE	PART NUMBER	DESCRIPTION	QTY.
1		1133084	7/16" WASHER	2
2		17157	7/16-20 X 1-1/4" HEX HEAD BOLT	2

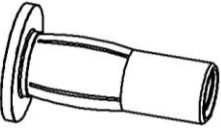
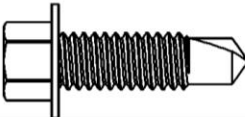
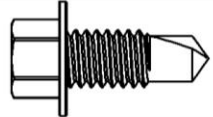
Hardware (Continued)

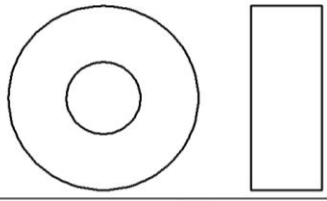
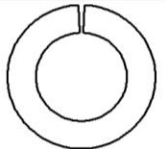
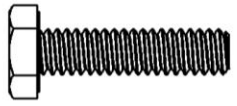
ITEM	HARDWARE TO SCALE	PART NUMBER	DESCRIPTION	QTY.
3		13800	1/4"-20 X 1-1/4" HEX HEAD BOLT	4
4		11126953	1/4"-20 X 5/8" FLANGED HEX HEAD	37
5		33618	1/4" LOCK WASHER	16
6		33078	1/4" FLAT WASHER	16
7		0167030	1/4"-20 FLANGED LOCK NUT	37
8		920313726	1/4"-20 PLUS NUT	4
9		0143576	5/16X1 SELF TAPPING	5
10		0143575	5/16 X 3/4" SELF TAPPING	5
11		38566	M6-1 X 25MM HEX HEAD BOLT	8
12		0162878	M6 U-NUT	2
13		11517442	3/8" ID 1" OD NYLON SPACER	4
14		33624	7/16" LOCKING WASHER	2
15		11241162	1/4"-20 X 1/2" HEX HEAD BOLT	4

Step 1 – Attach Side Wings

- Using four 1/4" x 5/8" flanged bolt and four 1/4" flanged lock nuts, bolt side wing to partition (40660).
- Snugly tighten.
- Repeat this step on opposite side partition.

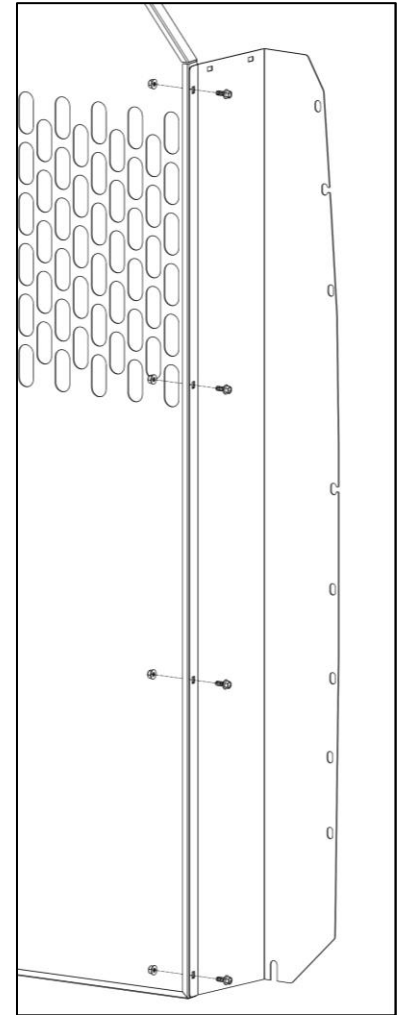
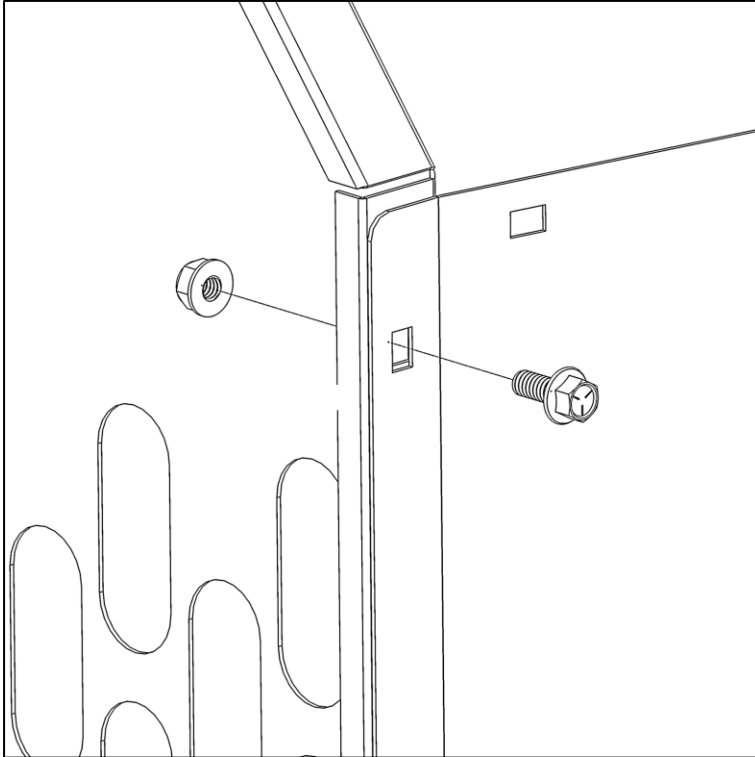

Step 2 – Attach Top Panel

- Using six 1/4" x 5/8" flanged bolts and six 1/4" flanged lock nuts, bolt top panel to partition.
- TIGHTEN hardware.

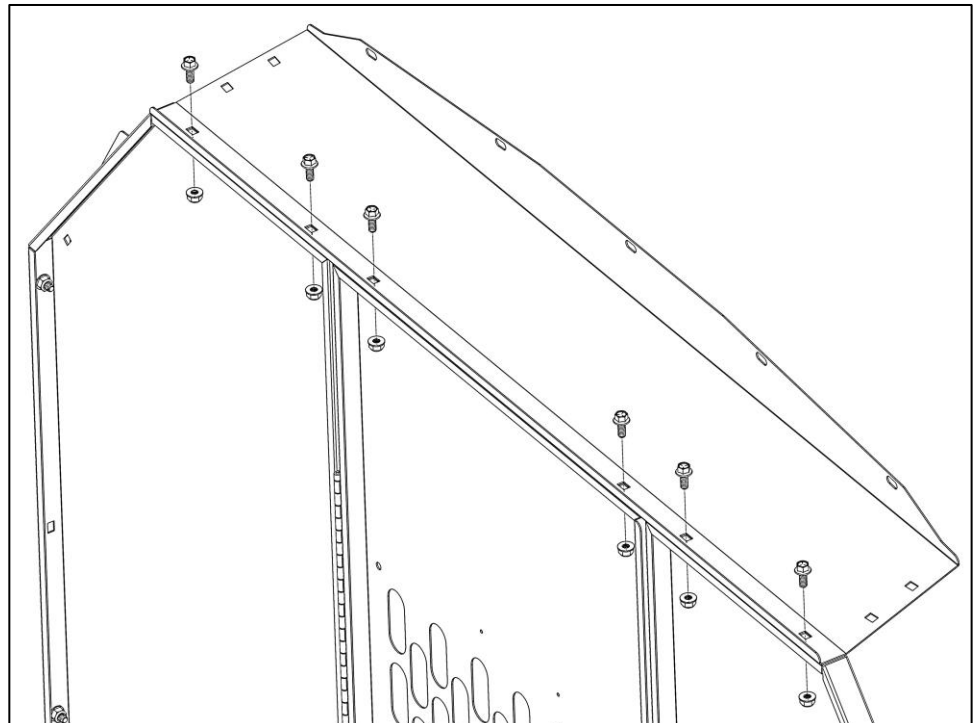

Step 3 – Attach Corner Panels

- Using two 1/4" x 5/8" flanged bolts and two 1/4" flanged lock nuts, bolt corner panel to partition.
- Snug tighten but allow for movement.

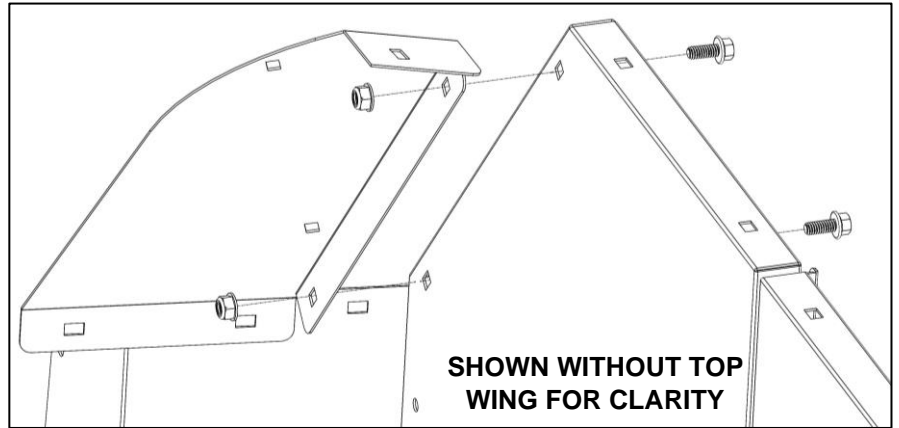

- Using a 1/4" x 5/8" flanged bolt and 1/4" flanged lock nut, bolt corner panel to top wing.
- Snug tighten but allow for movement.

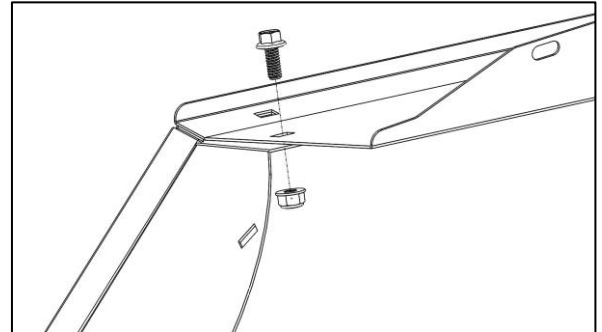

- Using a 1/4" x 5/8" flanged bolt and 1/4" flanged lock nut, bolt corner panel to side wing.

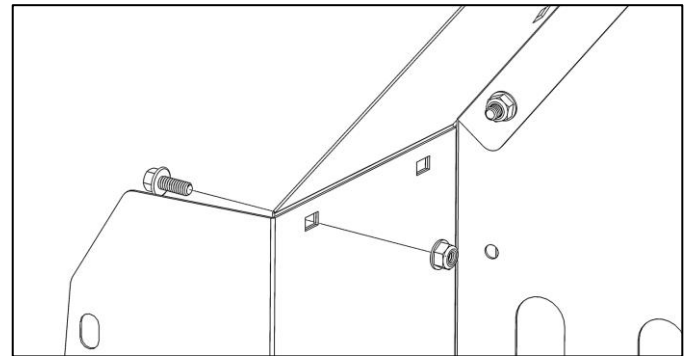

NOTE: DO NOT install a bolt in the holes closest to the partition corner on each side wing.

- Snug tighten but allow for movement.
- Repeat this step on opposite side of partition.

Step 4 – Attach Corner Brackets

NOTE: The corner brackets are side specific. Verify the correct bracket position prior to installing.

- Using a 1/4" x 5/8" flanged bolt and a 1/4" flanged lock nut, bolt each mid roof corner bracket into the holes closest to the partition on each scorner of the partition as shown. The holes used to attach these brackets were the holes the bolt was left out in the previous step.
- Snug tighten.

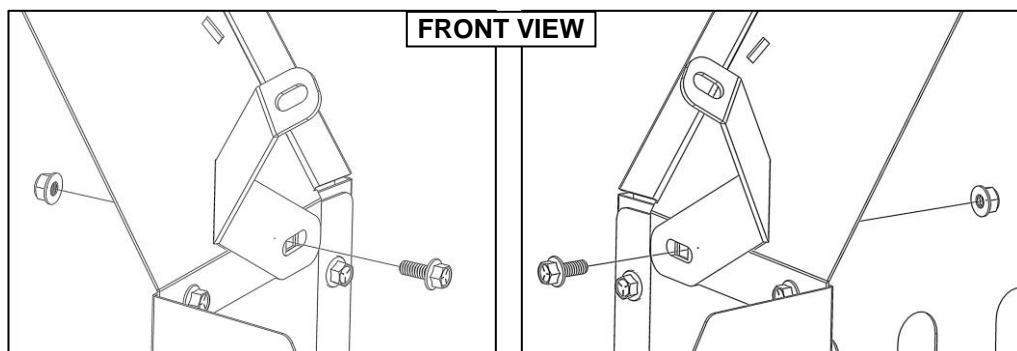

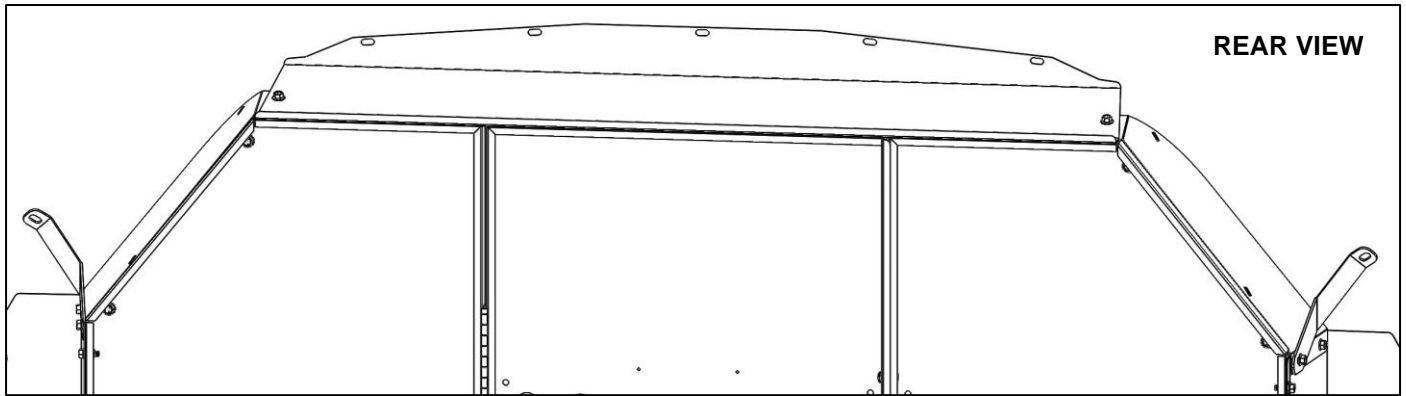

Step 5 – Attach Corner Wing Panels

NOTE: The corner brackets are side specific. Verify the correct bracket position prior to installing.

- Using 1/4" x 5/8" flanged bolts and 1/4" flanged locknuts, bolt each corner wing to corner panel.
- Snug tighten but allow for movement.

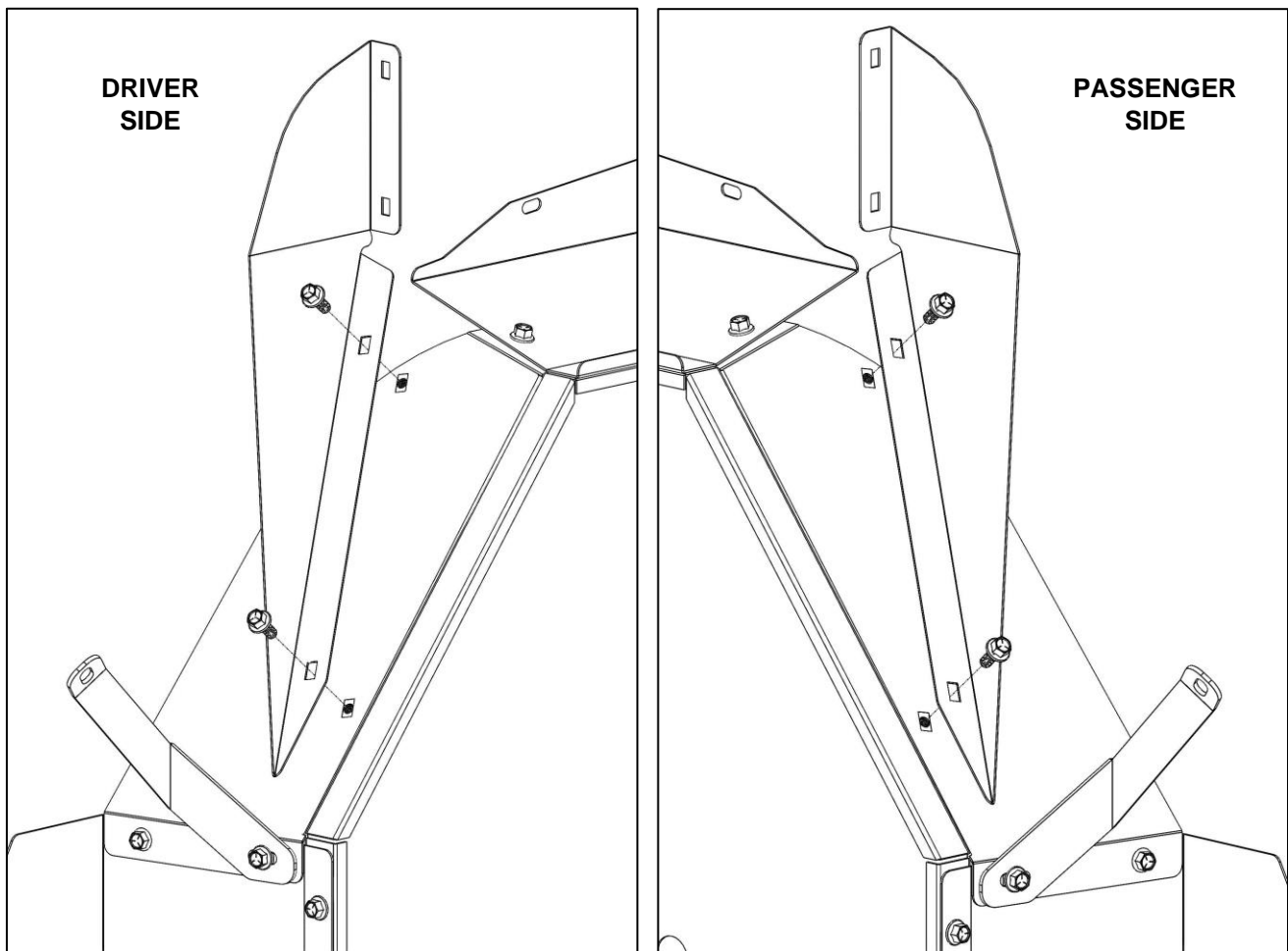

Step 6 – Attach Top Wing

- Using 1/4" x 5/8" flanged bolts and 1/4" flanged Locknuts, loosely bolt the top wing to the top panel.
- DO NOT tighten.

- Using two 1/4" x 5/8" flanged bolts and two 1/4" flanged locknuts, bolt each corner wing to corner panel.

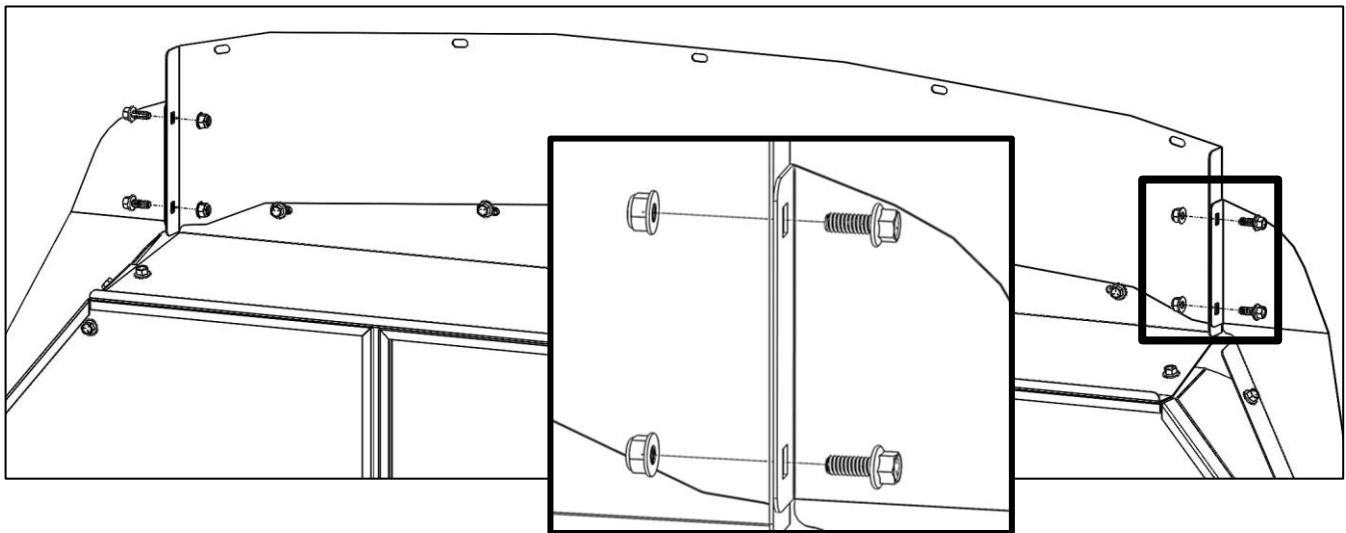
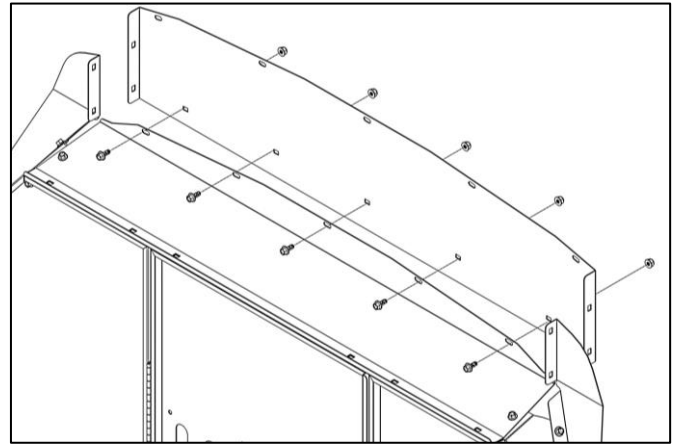

- Snug tighten but allow for movement.

Step 7 – Attach Bottom Plate

- Using four 1/4" x 1/2" hex head bolts, four 1/4" lock washer, and four 1/4" washers, bolt through the partition panels into the bottom panel.
- Snug tighten but allow for movement.

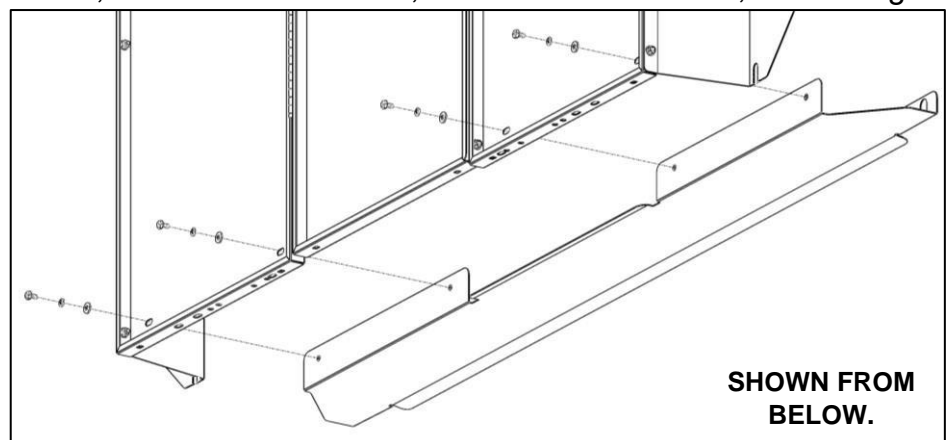

Step 8 – Remove Factory Installed D-Rings

- If D-rings are factory installed in the driver-side and passenger-side "B" pillars, remove D-rings.

Step 9 – Install Driver’s Side Wing to “B” Pillar

NOTE: On the driver side the wing kit can be installed using either U-nuts or the included plus nuts. Both instructions are shown below

U-Clips

- On the driver’s side, place one M6 clip-on U-nut in each of the two locations shown.

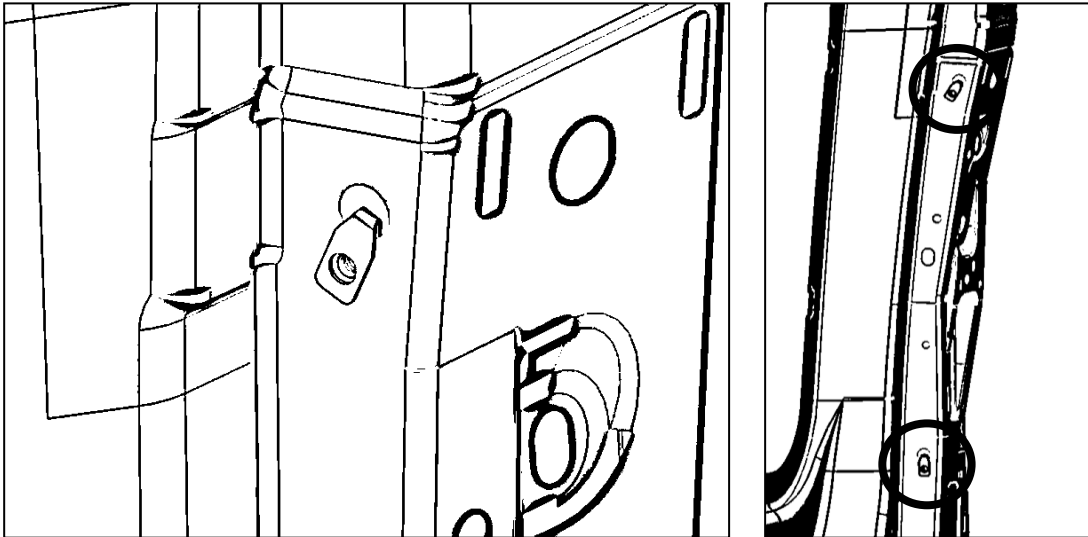

- Place assembled partition into van. **Be sure the wing panels are toward the front of the van and the perforated partition side panel in the 40660 is on the passenger side.**
- Press the assembled partition with wings firmly against the “B” pillar and the top wing across the roof support of the van.



Always ensure, when installing hardware through any installation surface, the area behind the installation surface is clear of electrical wiring or vehicle safety features.

- Bolt driver’s side wing to the M6 U-Clips using two M6 x 25mm hex head bolts, two 1/4” lock washers and two 1/4” flat washers.
- Snug tighten but allow for movement.

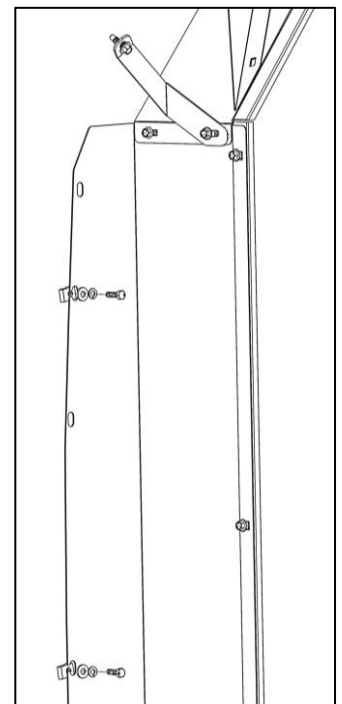
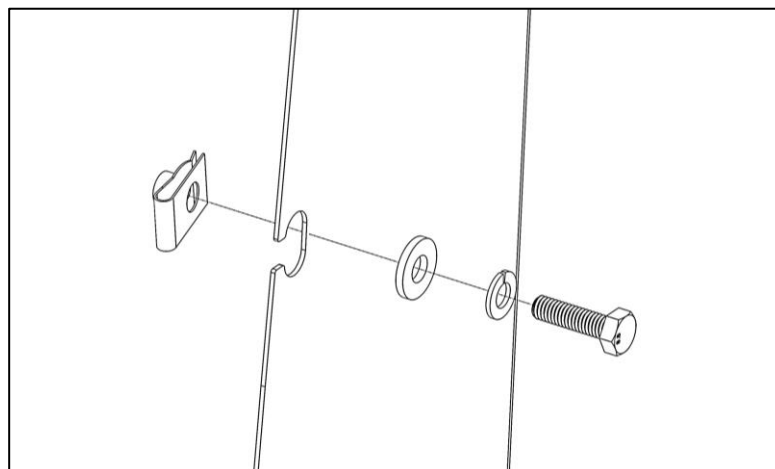

Plus Nuts

- Press the assembled partition with wings firmly against the “B” pillar and the top wing across the roof support of the van.
- Mark the holes shown.

NOTE: Ensure this is the location of where you want the partition to be installed.

- Move partition assembly so the previously marked holes can be accessed.
- Set partition assembly aside.



When installing hardware through any installation surface, always ensure the area behind the installation surface is clear of electrical wiring, fuel tank or lines, or any vehicle safety features.

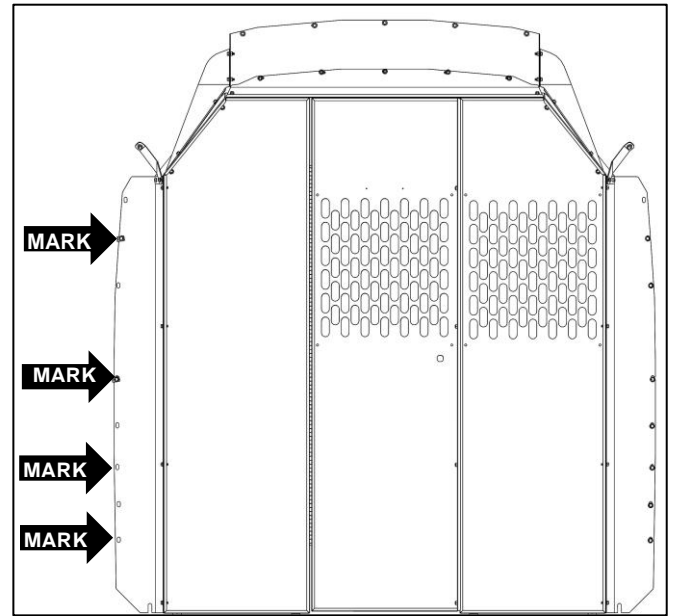

- At each marked location, drill hole using 25/64” drill bit and appropriate sized drill-bit stop collar. If 25/64” drill bit is not available, a 3/8” drill bit can be used, but it may be necessary to tap in plus nuts.
- Insert 1/4” x 2-1/4” hex head bolt through 1/4” flat washer and plus nut installation tool, then screw bolt into plus nut. Knurled end of plus nut tool must be directed away from bolt head and contacting plus nut.

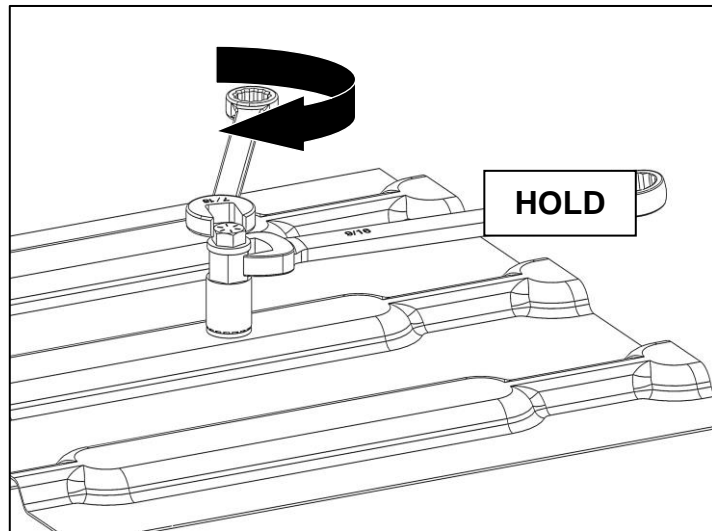
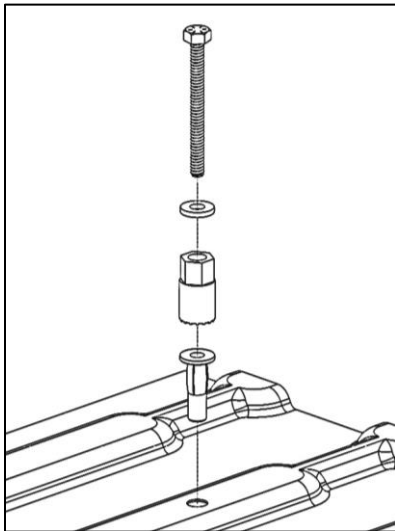

- Insert plus nut into hole with plus nut tool attached.
- Using the 9/16” box wrench, hold the plus nut tool stationary and then tighten hex head bolt until plus nut is tightly gripping and does not spin when hex bolt is loosened.
- DO NOT overtighten plus nut.
- Using the 9/16” box wrench, hold the plus nut tool stationary to remove the 1/4” hex head bolt.

- Using 1/4" x 1-1/4" hex heads, 1/4" lock washers, and 1/4" flat washers, bolt partition into plus nuts.
- Snug tighten but allow for movement.

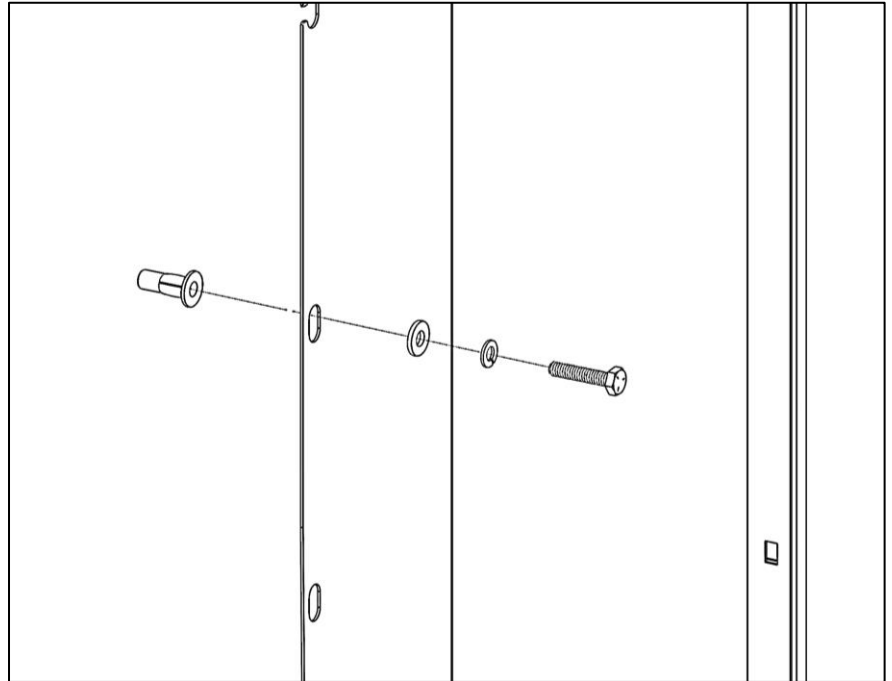

Step 10 – Install Passenger Wing to “B” Pillar

- Using M6 x 25mm hex heads, 1/4" lock washers, and 1/4" flat washers, bolt passenger side wing to the threaded embosses in the “B” pillar in the following locations, as shown.
- Snug tighten but allow movement.

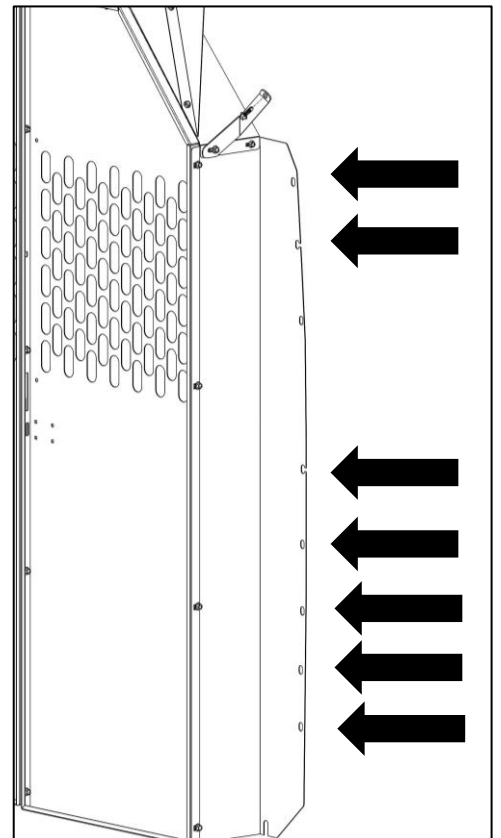
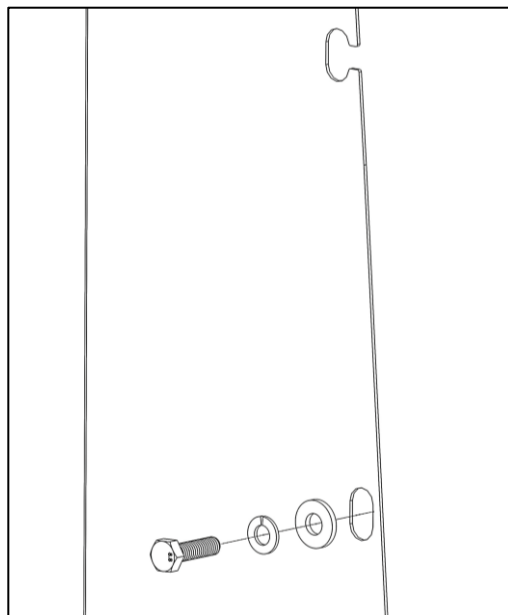

Step 12 – Install Top Wing to “B” Pillar



Always ensure, when installing hardware through any installation surface, the area behind the installation surface is clear of fuel tanks or lines, electrical wiring or vehicle safety features.

- Using **5/16” x 3/4”** self-tapping screws, install the top wing to the ceiling roof support.

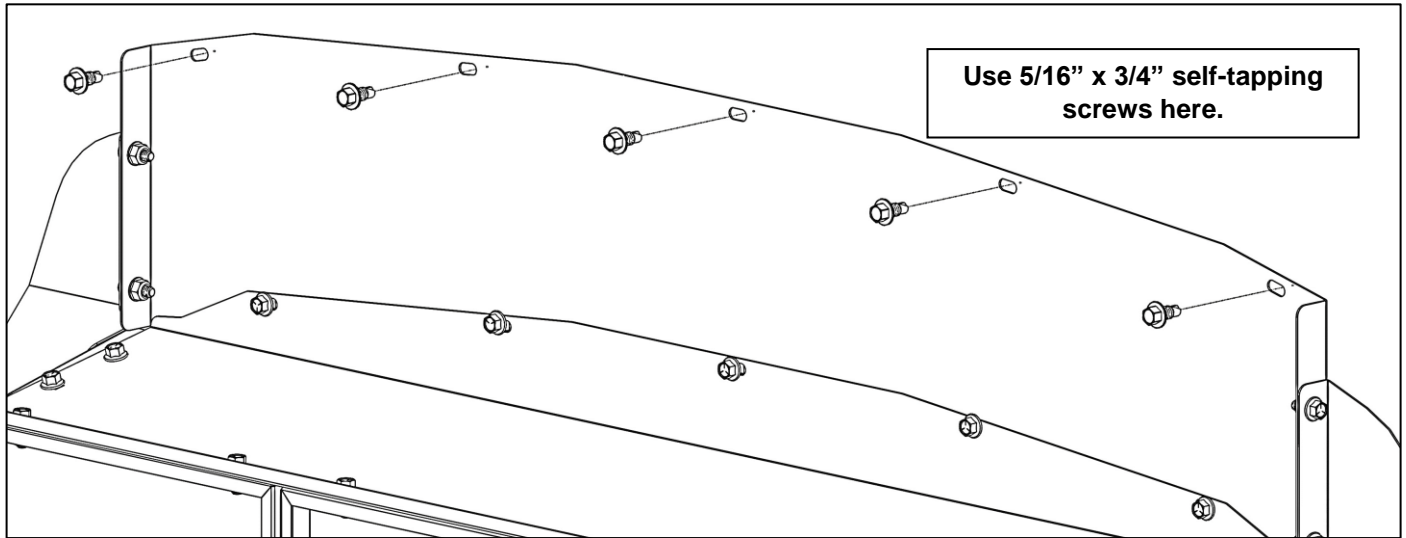

- Using **5/16” x 1”** self tapping screws, install the corner bracket to the “B” pillar as shown.
- Repeat on opposite side

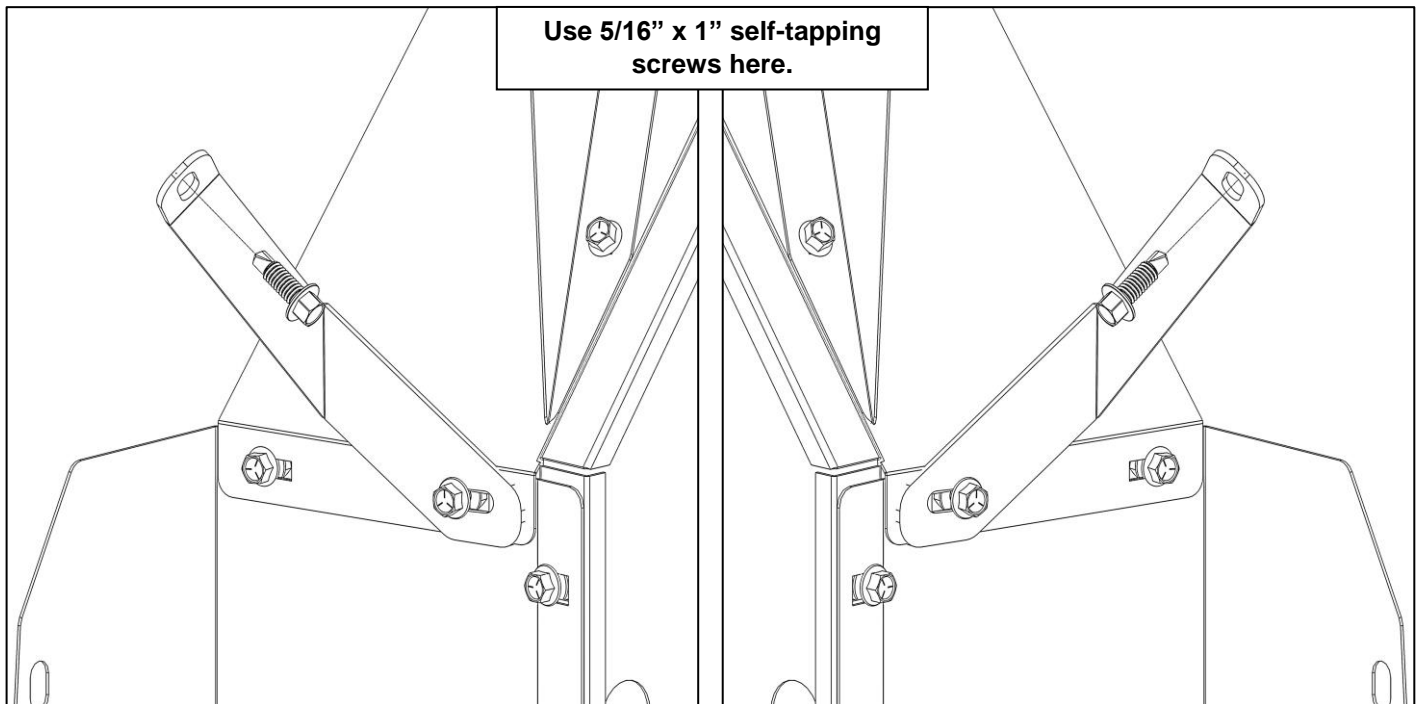

- Use 5/16" x 1" self tapping screws, secure the remaining three locations along the wings to each "B" Pillar.

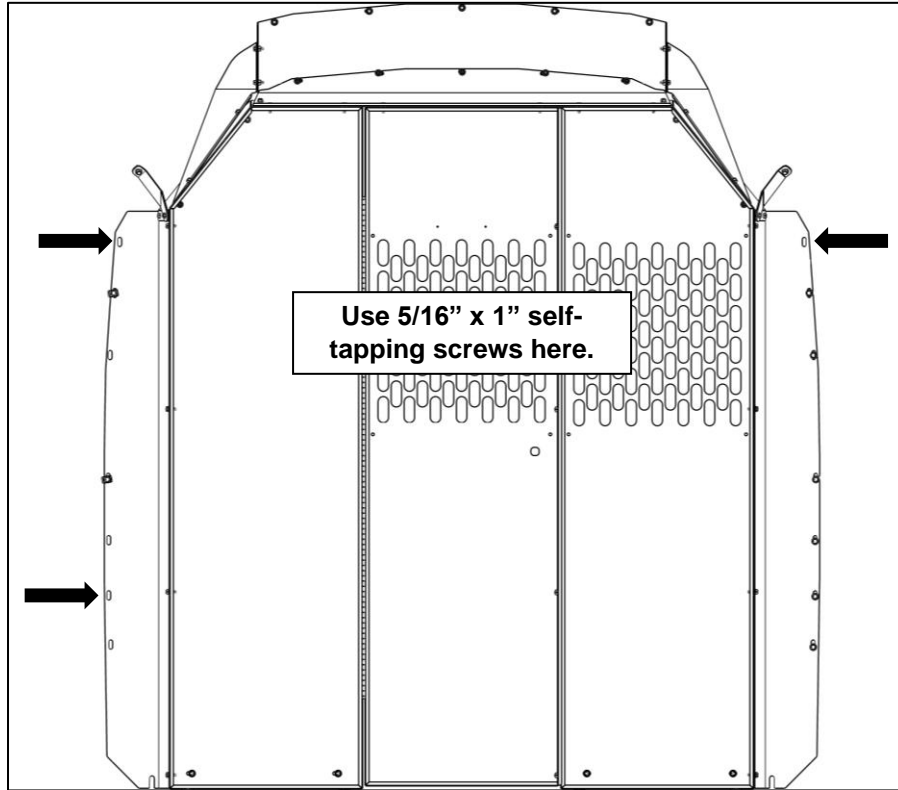

Step 13 – Install Wings to D-ring Holes

- If factory D-rings were factory installed and previously removed from "B" pillar, re-install D-rings through slots provided in both passenger-side and driver-side wings and through the large holes in the bottom panel.
- If factory D-rings were not provided by the vehicle manufacturer, install a 7/16" x 1-1/4" hex head bolt, 7/16" lock washer, and 7/16" flat washer through the slots in the bottom of driver side and passenger side wings.

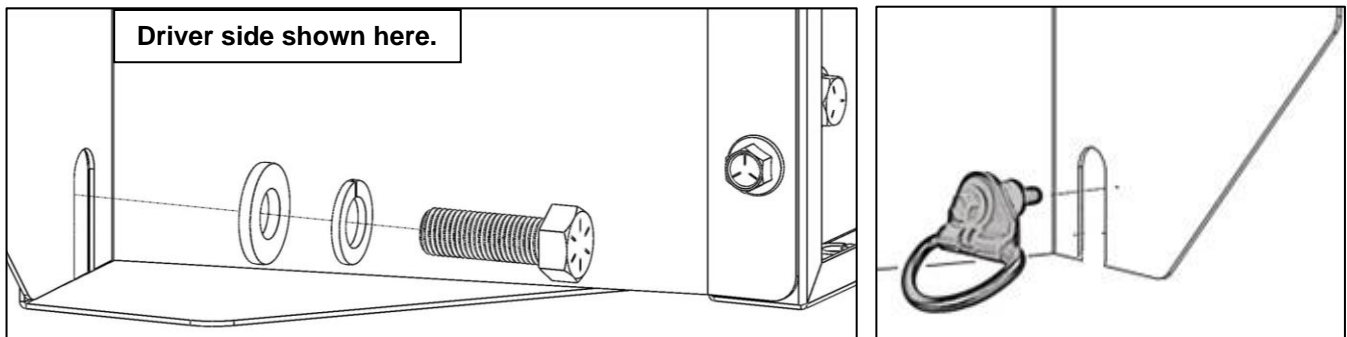

GO BACK AND ENSURE ALL HARDWARE IS TIGHTENED.

ASSEMBLY IS COMPLETE