

Holman

Instruction Guide 40669TM

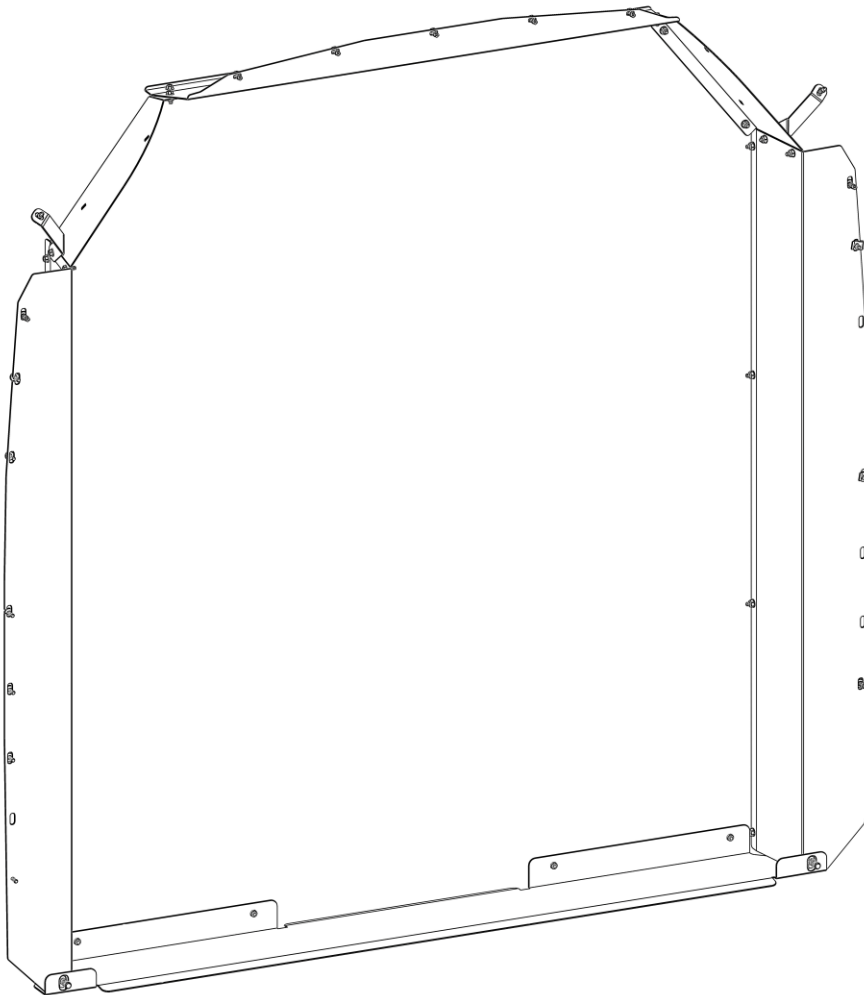

Holman
Rancho Cordova, CA 95742
800-343-7486
InstallationSupport@Holman.com

PLEASE READ ALL INSTRUCTIONS AND WARNINGS PRIOR TO ASSEMBLING, INSTALLING, AND USING THIS PRODUCT.

Warning



Always check for wires, fuel tanks and lines, air bags, brake lines, and other important vehicle functionality items prior to drilling and installing all products.

Tools Needed

5/8", 7/16", 1/2" Sockets	7/16", 9/16". 1/2" Box Wrenches
10mm Socket	10mm Hex Driver Bit
Drill	25/64" Drill Bit
Plus Nut Installation Tool (P9902)*	Drill Bit Stop Collar

* Sold Separately.

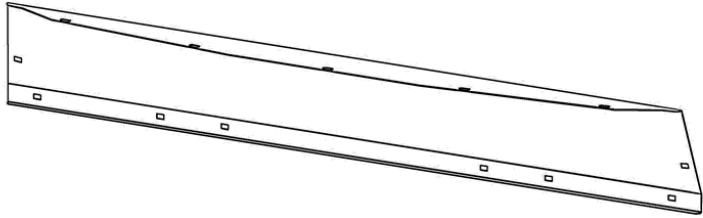
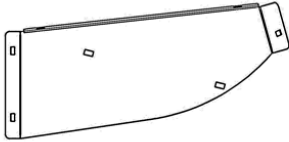
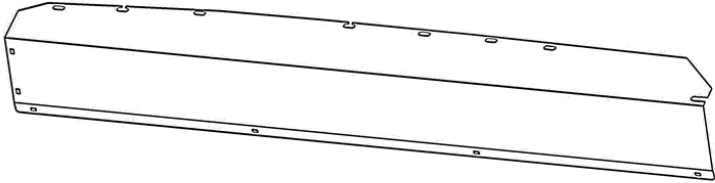
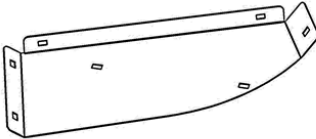
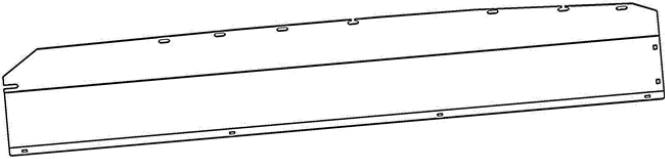

Table of Contents

Before You Begin.....	1
Parts List.....	2
Hardware	3
Hardware (Continued)	4
Step 1 – Attach Side Wings	4
Step 2 – Attach Top Wing	5
Step 3 – Attach Corner Panels	5
Step 4 – Attach Corner Bracket	6
Step 5 – Attach Sill Plate	6
Step 6 – Remove Factory Installed D-Rings	7
Step 7 – Install Driver’s Side Wing to “B” Pillar	7
U-Clips	7
Plus Nuts	8
Step 8 – Install Passenger Wing to “B” Pillar	9
Step 9 – Install Top Wing to “B” Pillar	10
Step 10 – Install Wings to D-ring Holes	11



Before You Begin

- Read all instructions prior to installing any Holman product.
- **Be sure to have a tall partition (40660, 40661, 40662, or 40665) assembled and ready to be installed.**
- **Plus Nut Installation Kit (P9902) does not come included and must be purchased separately.**

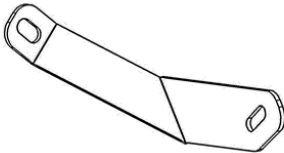
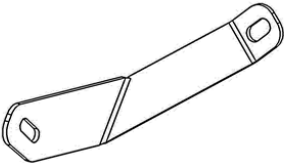
Parts List

ITEM NO.	ITEM	PART NUMBER	DESCRIPTION	QTY
1		100769	TRANSIT HR TOP PANEL	1
2		100767	TRANSIT MR CORNER PANEL PS	1
3		406TH-10-001	TRANSIT MR PS WING	1
4		100768	TRANSIT MID-ROOF CORNER PANEL DS	1
5		406TH-10-001-MIRROR	TRANSIT MR DS WING	1
6		101240	TRANSIT SILL PLATE	1
7		406TH-10-004-MIRROR	TRANSIT MR CORNER BRACKET LH DS	1
8		406TH-10-004	TRANSIT MR CORNER BRACKET RH PS	1
9		18-40669TM	TRANSIT-MR HARDWARE	1

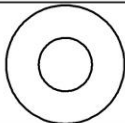
Hardware

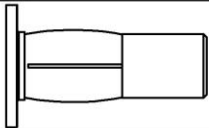
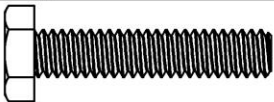
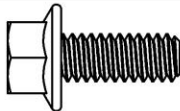
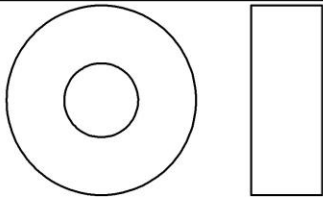
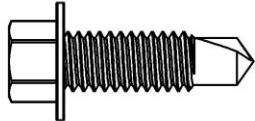
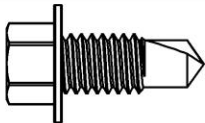
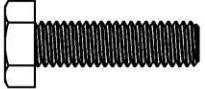
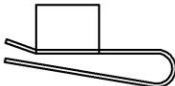
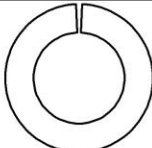
ITEM	HARDWARE TO SCALE	PART NUMBER	DESCRIPTION	QTY.
1		33078	1/4" FLAT WASHER	16
2		33618	1/4" LOCK WASHER	16
3		0167030	1/4"-20 FLANGED LOCK NUT	24
4		920313726	1/4"-20 PLUS NUT	4
5		13800	1/4"-20 X 1-1/4" HEX HEAD BOLT	4
6		11126953	1/4"-20 X 5/8" FLANGED HEX HEAD	24
7		11517442	3/8" ID 1" OD NYLON SPACER	4
8		0143576	5/16X1 SELF TAPPING	6
9		0143575	5/16 X 3/4" SELF TAPPING	5
10		38566	M6-1 X 25MM HEX HEAD BOLT	8
11		0162878	M6 U-NUT	2
12		33624	7/16" LOCKING WASHER	2

Hardware (Continued)

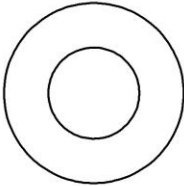
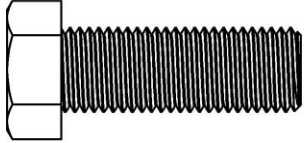
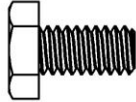
ITEM	HARDWARE TO SCALE	PART NUMBER	DESCRIPTION	QTY.
13		1133084	7/16" WASHER	2
14		17157	7/16"-20 X 1-1/4" Hex Head Bolt	2
15		11241162	1/4"-20 X 1/2" HEX HEAD BOLT	4

Step 1 – Attach Side Wings

- Using four 5/16" x 5/8" flanged bolts and four 5/16" flanged lock nuts, bolt side wing to partition.
- Snugly tighten.
- Repeat this step on opposite side of the partition.

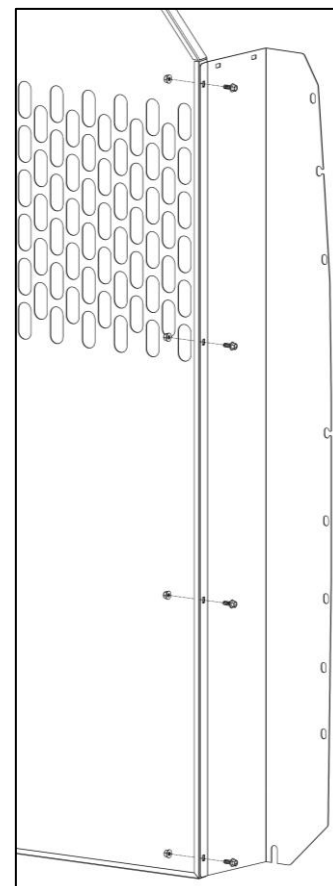
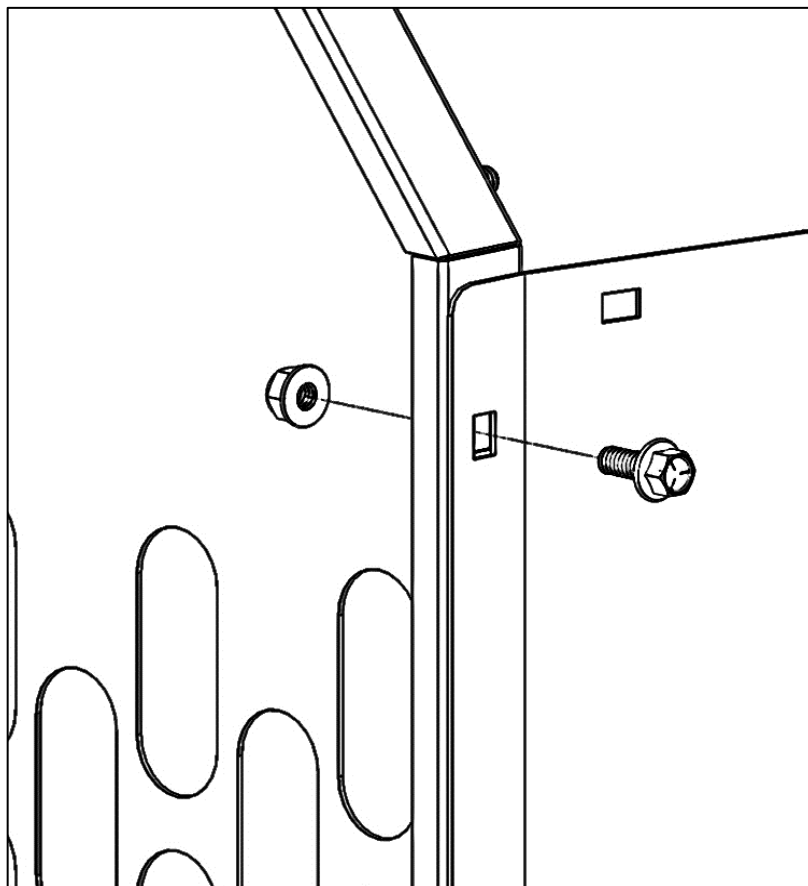

Step 2 – Attach Top Wing

- Using six 5/16" x 5/8" flanged bolts and six 5/16" flanged lock nuts, bolt top wing to partition.
- TIGHTEN hardware.

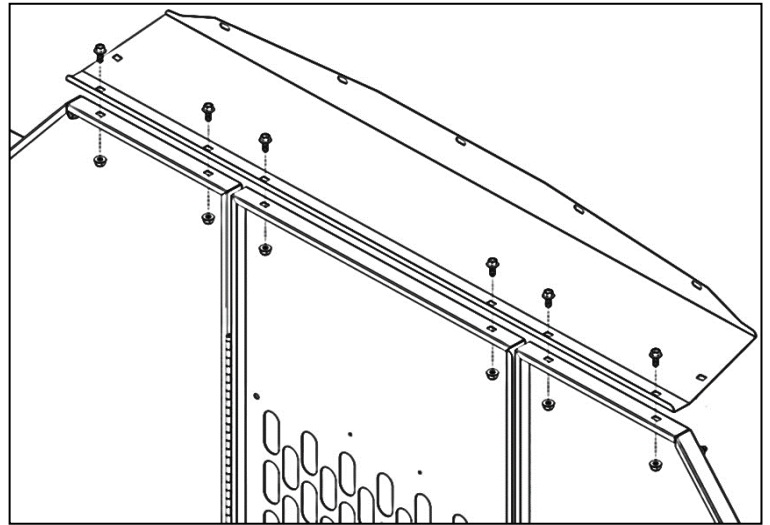

Step 3 – Attach Corner Panels

- Using two 5/16" x 5/8" flanged bolts and two 5/16" flanged lock nuts, bolt corner panel to partition.
- Snug tighten but allow for movement.

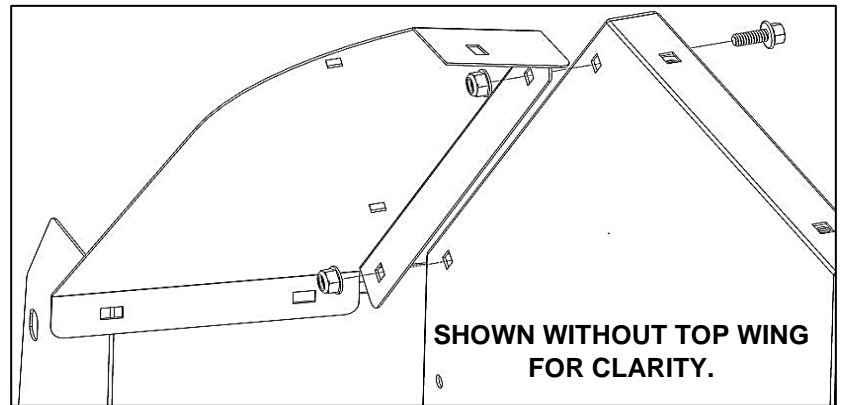

- Using one 5/16" x 5/8" flanged bolt and one 5/16" flanged lock nut, bolt corner panel to top wing.
- Snug tighten but allow for movement.

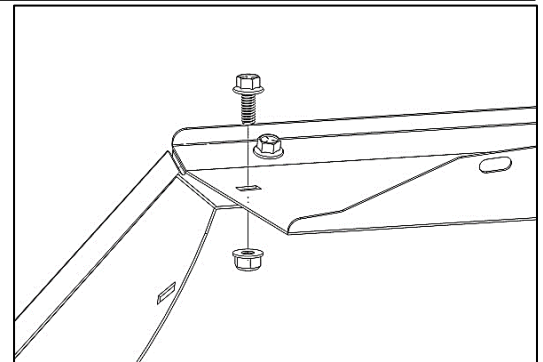

- Using one 5/16" x 5/8" flanged bolt and one 5/16" flanged locknut, bolt corner panel to side wing.

NOTE: DO NOT install a bolt in the holes closest to the partition on each side wing.

- Snug tighten but allow for movement.
- Repeat this step on opposite side of partition for opposite side corner panel.

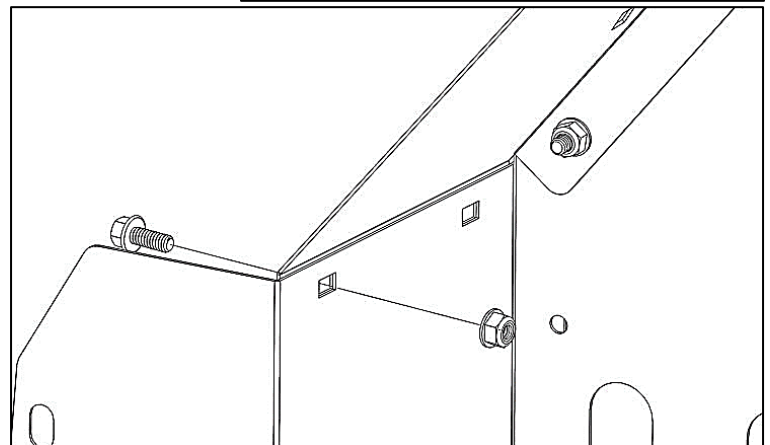

Step 4 – Attach Corner Bracket

NOTE: The corner brackets are side specific. Verify the correct bracket position prior to installing.

- Using a 5/16" x 5/8" flanged bolt and a 5/16" flanged lock nut, bolt each mid roof corner bracket into the holes closest to the partition on each corner of the partition as shown. The holes used to attach these brackets were the holes bolt was left out in the previous step.
- Snug tighten but allow for movement.

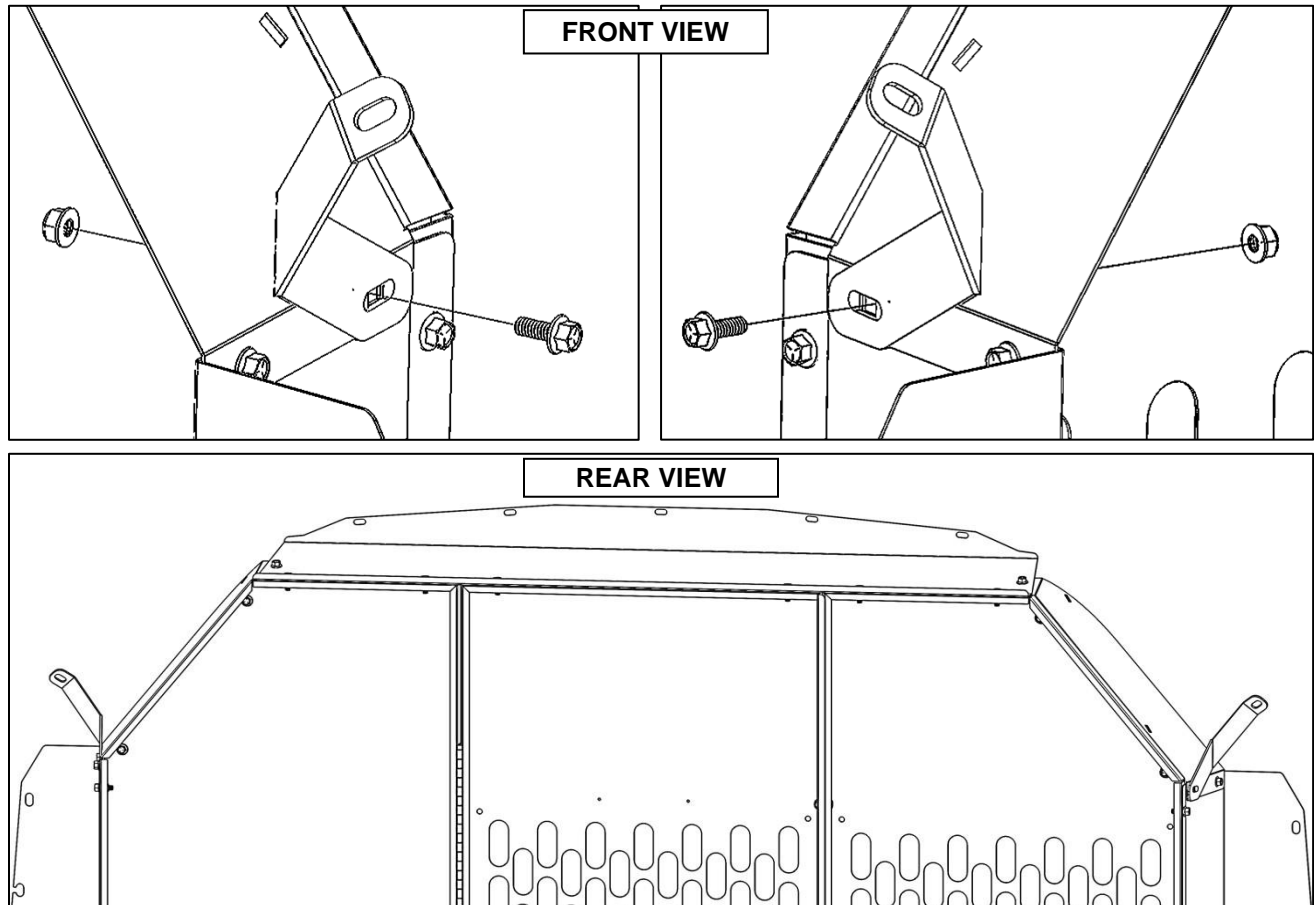

Step 5 – Attach Sill Plate

- Using four 1/4" x 1/2" hex head bolts, four 1/4" lock washer, and four 1/4" washers, bolt through the partition panels into the Sill plate.
- Snug tighten but allow for movement.

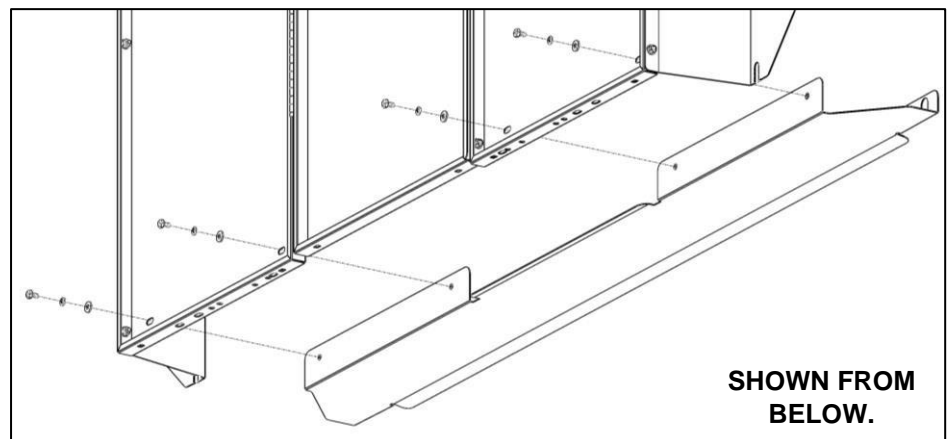

Step 6 – Remove Factory Installed D-Rings

- If D-rings are factory installed in the driver-side and passenger-side “B” pillars, remove D-rings.

Step 7 – Install Driver’s Side Wing to “B” Pillar

NOTE: On the driver side the wing kit can be installed using either U-nuts or the included plus nuts. Both instructions are shown below

U-Clips

- On the driver’s side, place one M6 clip-on U-nut in each of the two locations shown.

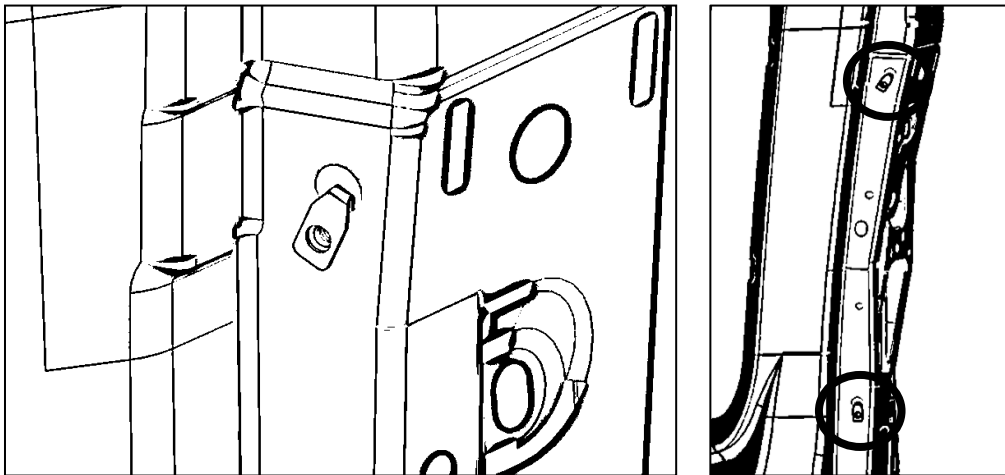

- Place assembled partition into van. **Be sure the wing panels are toward the front of the van and the perforated partition side panel in the partition is on the passenger side.**
- Press the assembled partition with wings firmly against the “B” pillar and the top wing across the roof support of the van.



Always ensure, when installing hardware through any installation surface, the area behind the installation surface is clear of electrical wiring or vehicle safety features.

- Bolt driver’s side wing to the M6 U-Clips using two M6 x 25mm hex head bolts, two 1/4” lock washers and two 1/4” flat washers.
- Snug tighten but allow for movement.

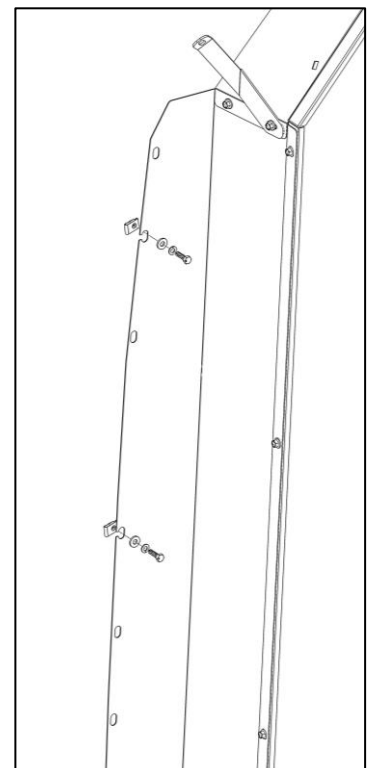
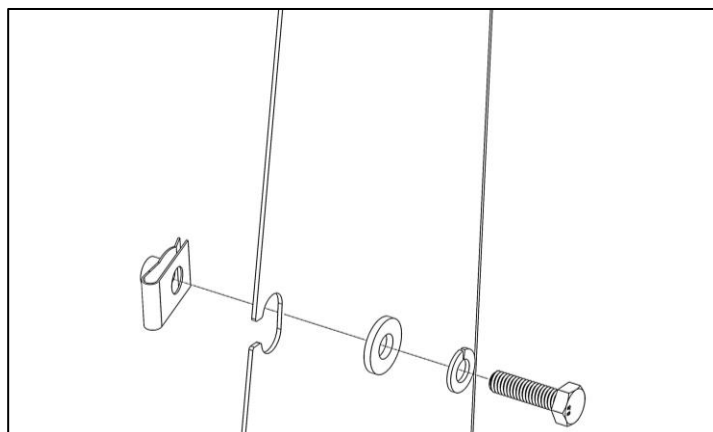

Plus Nuts

- Press the assembled partition with wings firmly against the “B” pillar and the top wing across the roof support of the van.
- Mark the holes shown.

NOTE: Ensure this is the location of where you want the partition to be installed.

- Move partition assembly so the previously marked holes can be accessed.
- Set partition assembly aside.



When installing hardware through any installation surface, always ensure the area behind the installation surface is clear of electrical wiring, fuel tank or lines, or any vehicle safety features.

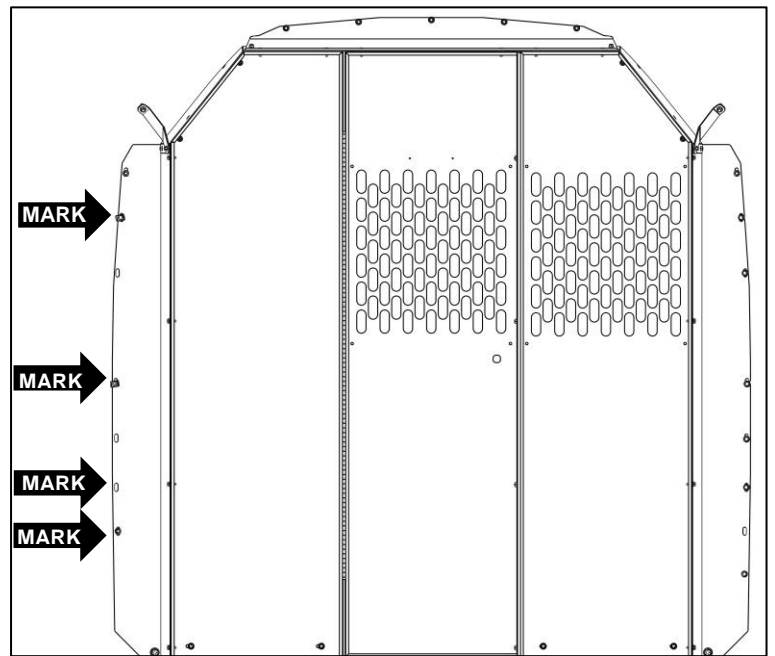

- At each marked location, drill hole using 25/64” drill bit and appropriate sized drill-bit stop collar. If 25/64” drill bit is not available, a 3/8” drill bit can be used, but it may be necessary to tap in plus nuts.
- Insert 1/4” x 2-1/4” hex head bolt through 1/4” flat washer and plus nut installation tool, then screw bolt into plus nut. Knurled end of plus nut tool must be directed away from bolt head and contacting plus nut.

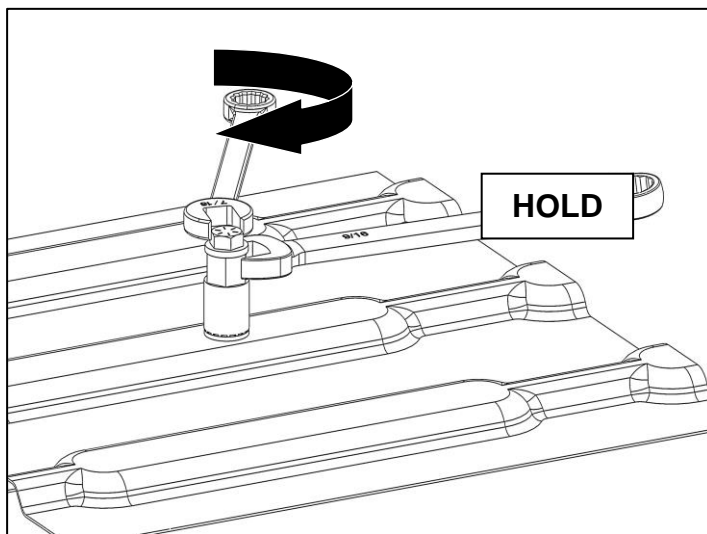
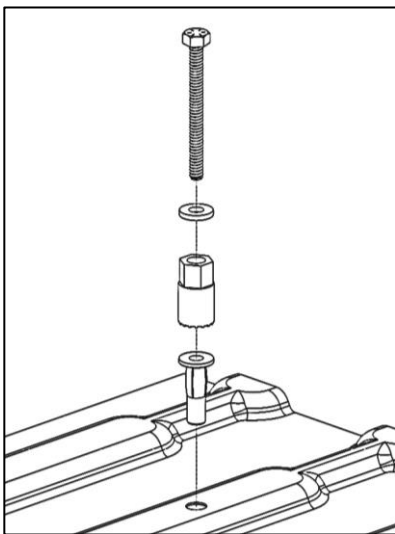

- Insert plus nut into hole with plus nut tool attached.
- Using the 9/16” box wrench, hold the plus nut tool stationary and then tighten hex head bolt until plus nut is tightly gripping and does not spin when hex bolt is loosened.
- DO NOT overtighten plus nut.
- Using the 9/16” box wrench, hold the plus nut tool stationary to remove the 1/4” hex head bolt.

- Using 1/4" x 1-1/4" hex heads, 1/4" lock washers, and 1/4" flat washers, bolt partition into plus nuts.
- Snug tighten but allow for movement.

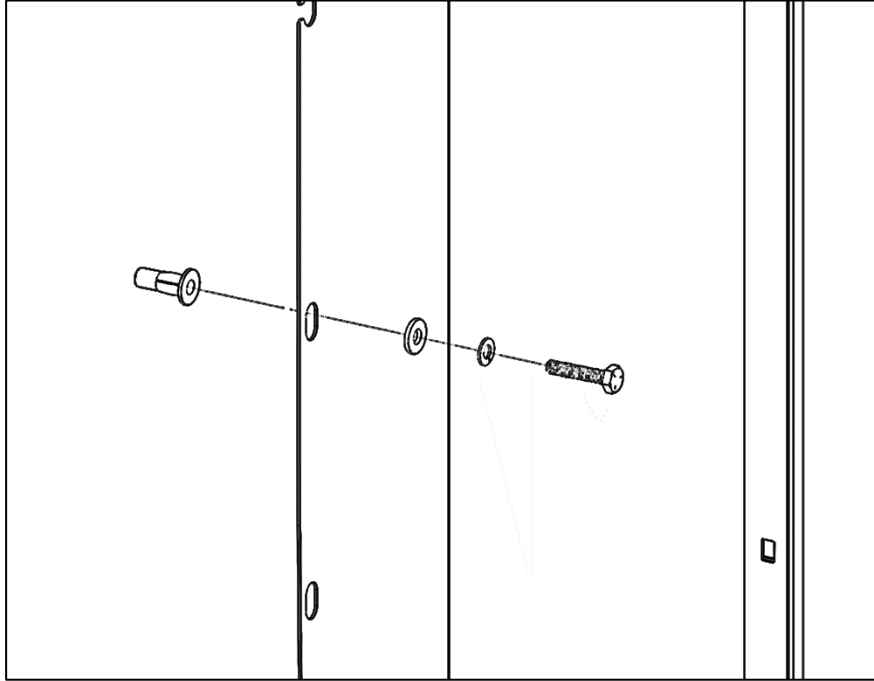

Step 8 – Install Passenger Wing to “B” Pillar

- Using M6 x 25mm hex heads, 1/4" lock washers, and 1/4" flat washers, bolt passenger side wing to the threaded embosses in the “B” pillar in the following locations, as shown.
- Repeat for a total of 6 locations as shown.
- Snug tighten.

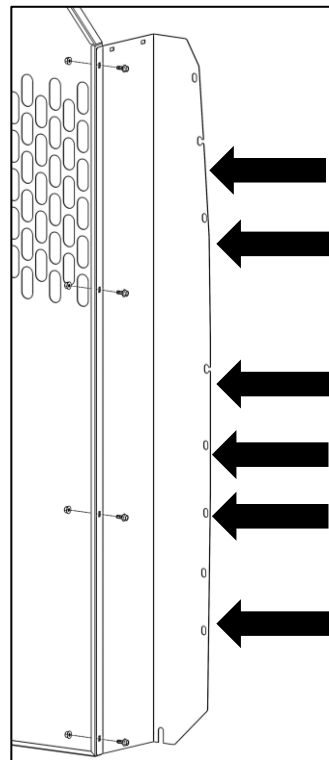
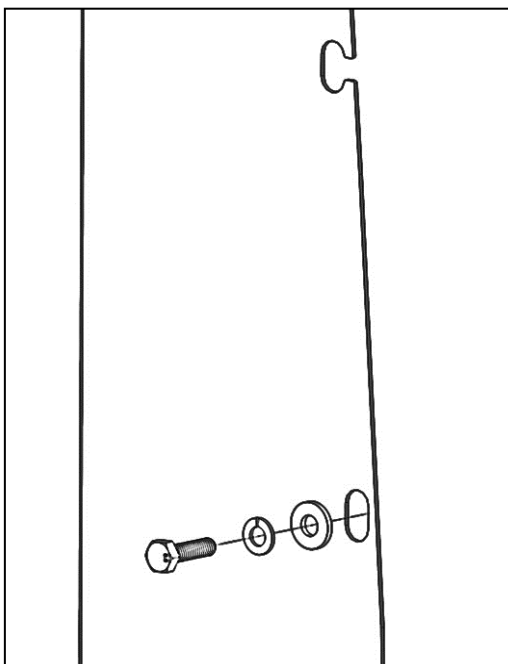

Step 9 – Install Top Wing to “B” Pillar



Always ensure, when installing hardware through any installation surface, the area behind the installation surface is clear of fuel tanks or lines, electrical wiring or vehicle safety features.

- Using 5/16" x 3/4" self tapping screws, install the top wing to the “B” pillar as shown.

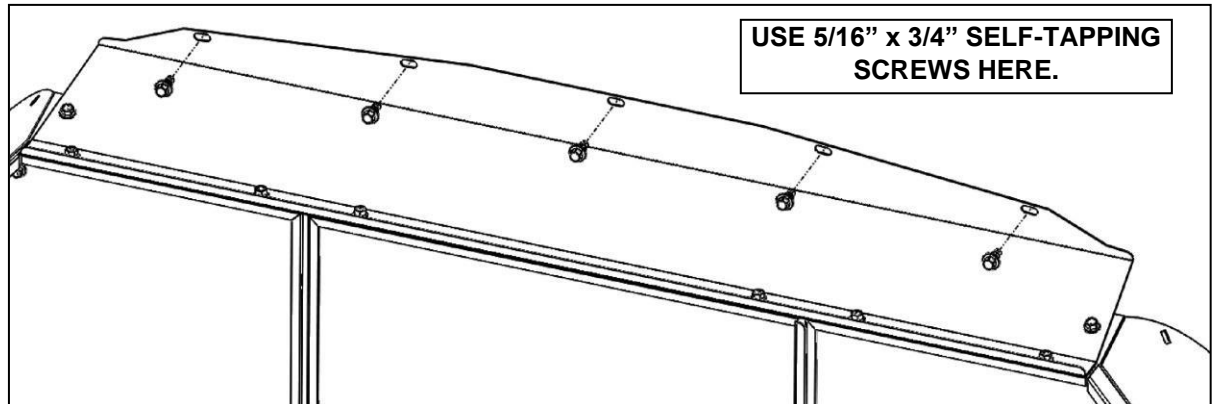

- Using 5/16" x 1" self tapping screws, install the corner brackets to the “B” pillar as shown.

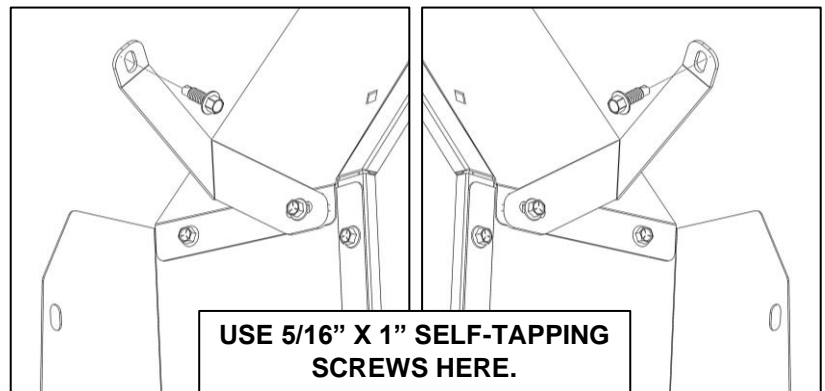

- In the remaining locations along the wings, as shown, secure wings to the “B” pillars using 5/16" x 1" self-tapping screws.

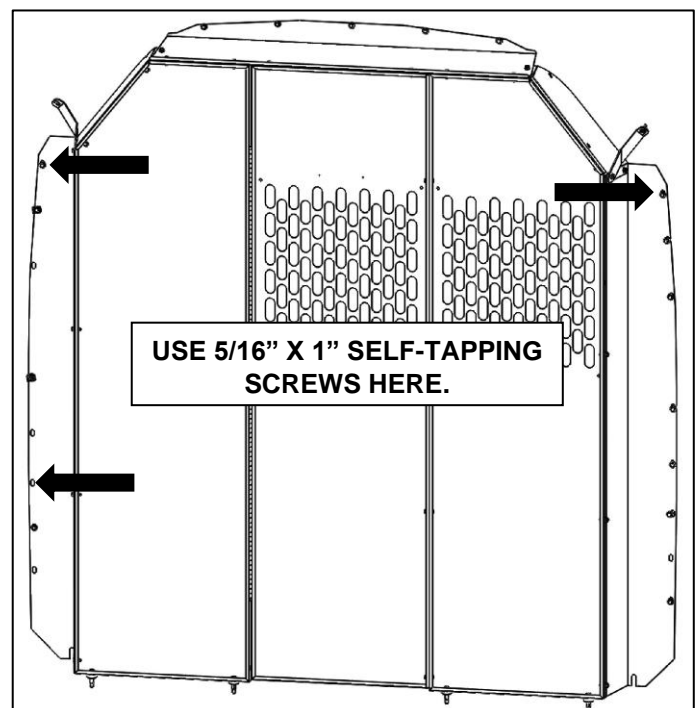

Step 10 – Install Wings to D-ring Holes

- If factory D-rings were factory installed and previously removed from “B” pillar, re-install D-rings through slots provided in both passenger-side and driver-side wings.
- If factory D-rings were not provided by the vehicle manufacturer, install a 7/16” x 1-1/4” hex head bolt, 7/16” lock washer, and 7/16” flat washer through the slots in the bottom of driver side and passenger side wings.

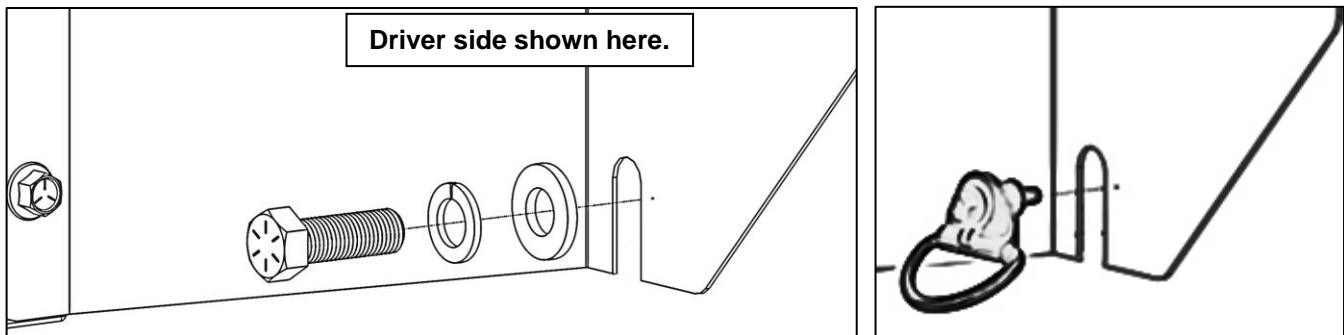

GO BACK AND ENSURE ALL HARDWARE IS TIGHTENED.

INSTALLATION IS COMPLETE