

# Holman

---

## Installation Guide

### 406TLF-P

---

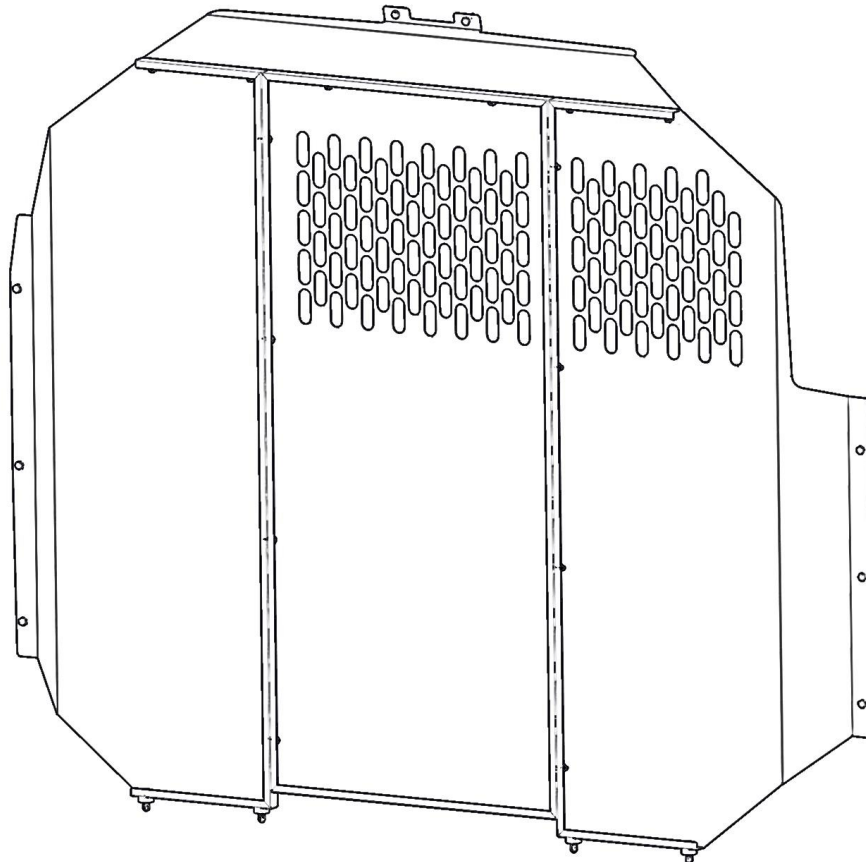

---

Holman  
Rancho Cordova, CA 95742  
800-343-7486  
InstallationSupport@Holman.com

---

---

## PLEASE READ ALL INSTRUCTIONS AND WARNINGS PRIOR TO ASSEMBLING, INSTALLING, AND USING THIS PRODUCT.

---

### Warning



Always check for wires, fuel tanks and lines, brake lines, and other important vehicle functionality items prior to drilling and installing all products.

---

### Tools Needed

7/16" Socket and Wrench	3/8" Socket and Wrench
25/64" Drill Bit	Drill

---

### Table of Contents

Parts List .....	2
Hardware List .....	3
<u>Assembly</u>	
Step 1 – Bolt Panels Together.....	4
Step 2 – Repeat on Drivers Side .....	5
Step 3 – Top Wing .....	6
<u>Installation</u>	
Step 1 – Prepare to install Plus Nuts .....	7
Step 2 – Install Plus Nuts .....	8
Step 3 – Bolt Partition .....	8

---





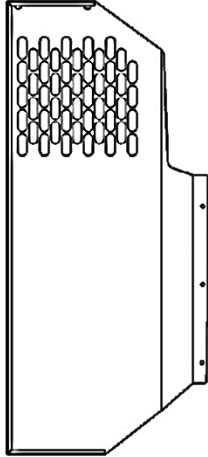
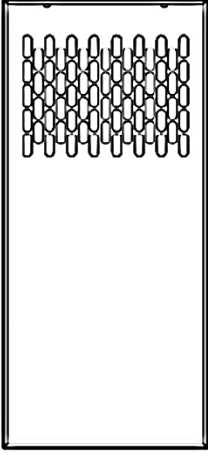
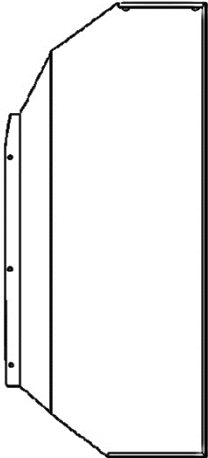
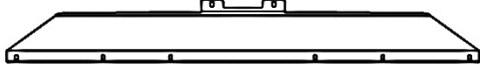

### Before You Begin

- Read all instructions.
- These instructions are shown using panels with view holes in them. All instructions are the same.

## Parts

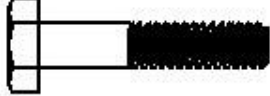
ITEM NO.	406TLF-P	PART NUMBER	DESCRIPTION	QTY.
A		406TLF-P1-001	Passenger Side Panel	1
B		406TLF-P1-002	Center Panel	1
C		406TLF-10-003	Driver Side Panel	1
D		406TLF-10-004	Top Wing	1
		18-406TLF	HARDWARE	1

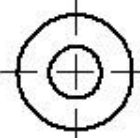
## Hardware

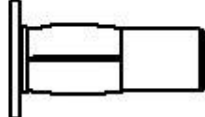
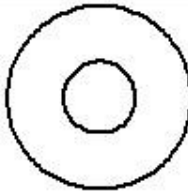
ITEM	HARDWARE TO SCALE	PART NUMBER	DESCRIPTION	QTY.
1		11126953	1/4"-20 X 5/8" FLANGED HEX HEAD	14
2		13005	1/4"-20 X 1" HEX HEAD BOLT	8
3		13007	1/4"-20 X 1-1/4" HEX HEAD BOLT	4
4		33618	1/4" LOCK WASHER	12
5		33078	1/4" FLAT WASHER	12
6		0167030	1/4"-20 FLANGED LOCK NUT	14
7		920313726	1/4"-20 Plus Nut	12
8		11517442	3/8" ID 1" OD NYLON Spacer	4

## Assembly

### Step 1 – Bolt Panels Together

- Using a 1/4" x 5/8" flanged hex head bolt and a 1/4" flanged nylock nut, bolt passenger side panel (A) to middle panel (B), as shown.
- Be sure the flanges on both panels are facing the same direction.
- Repeat a total of 4 times.

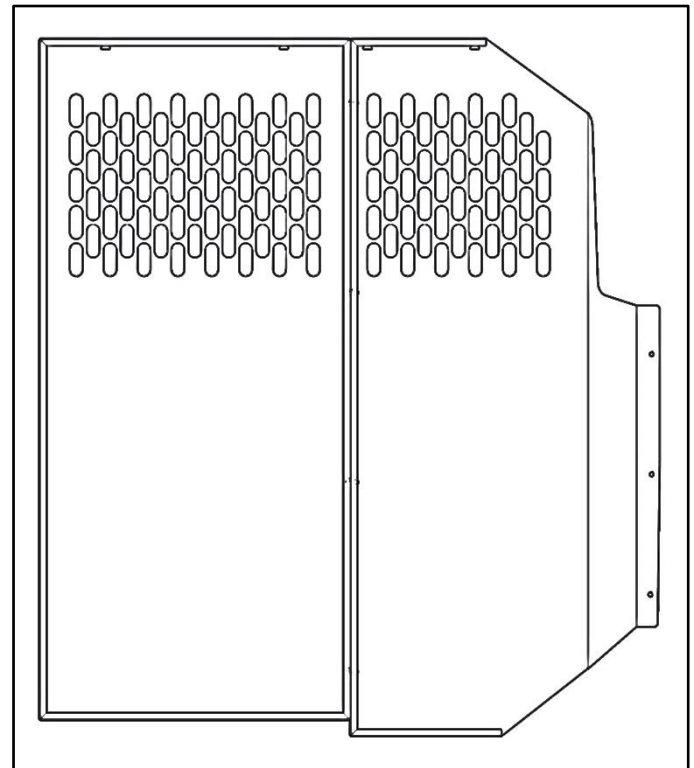
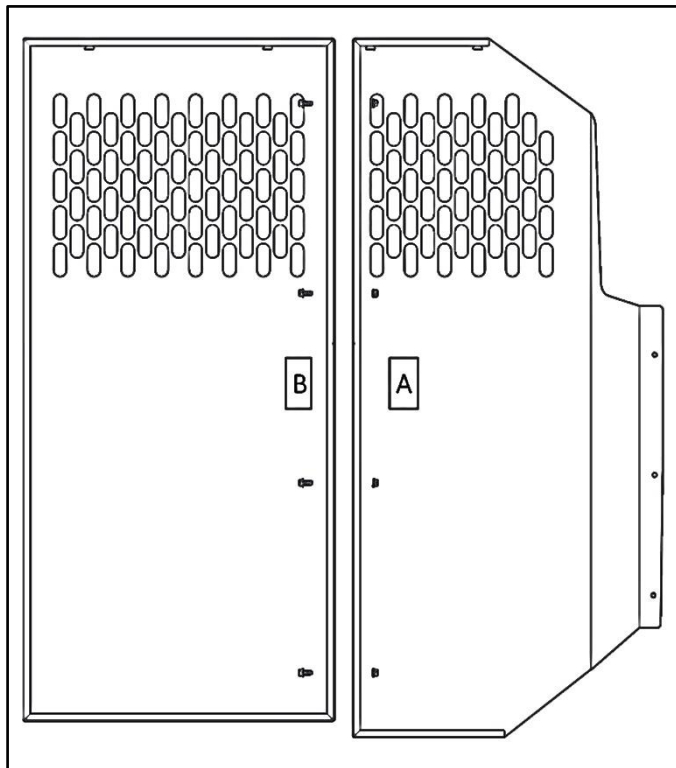
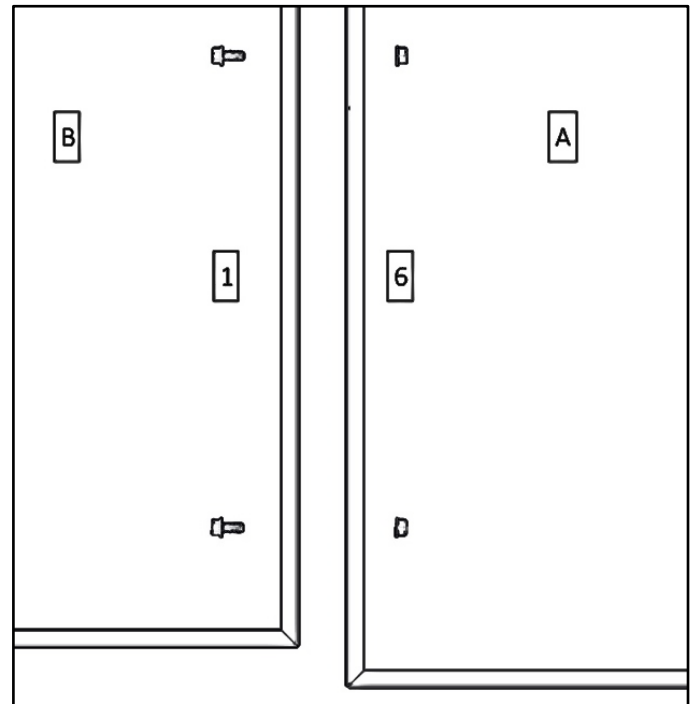

## Step 2 – Repeat on Drivers Side

- Using a 1/4" x 5/8" flanged hex head bolt and a 1/4" flanged nylock nut, bolt passenger side panel (A) to middle panel (B), as shown.
- Be sure the flanges on both panels are facing the same direction.
- Repeat a total of 4 times.

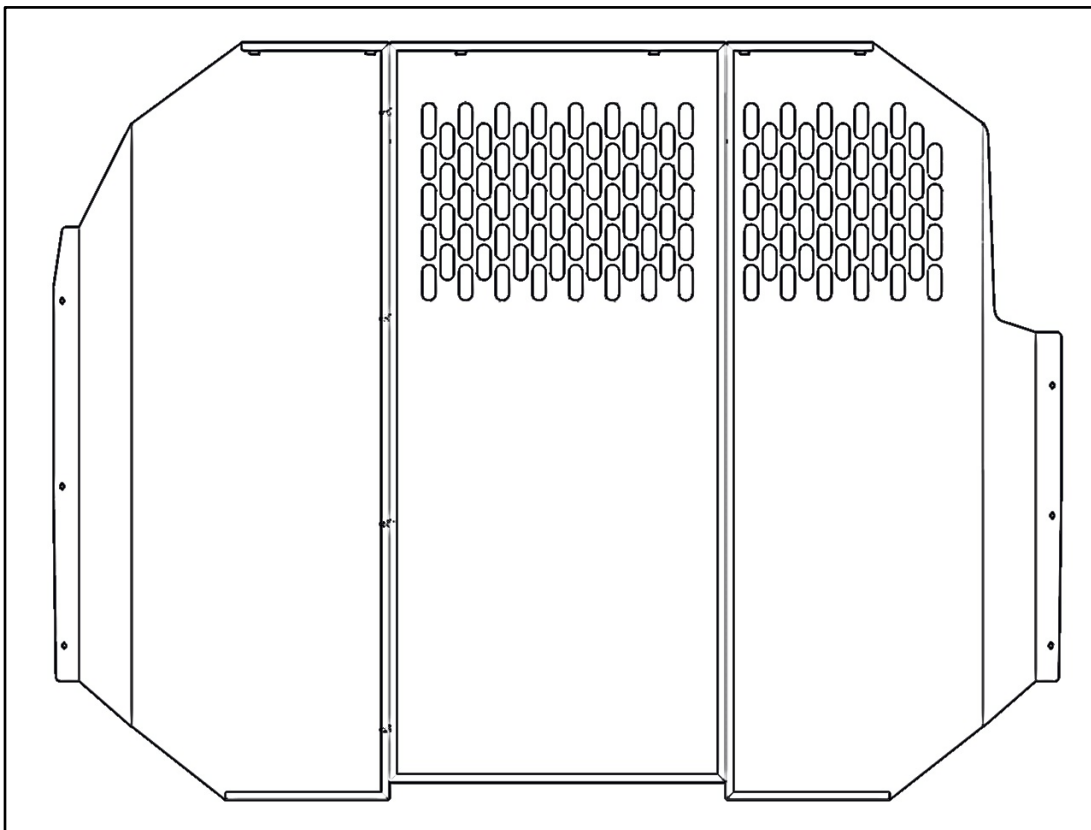
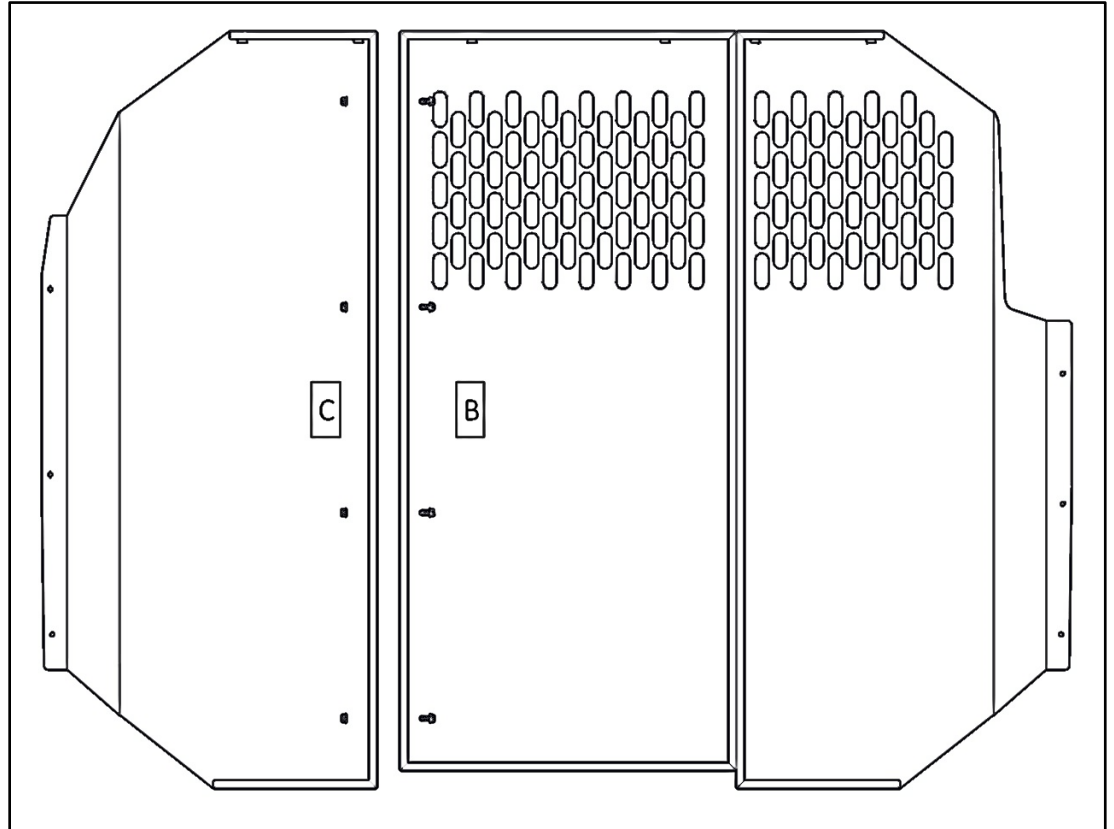

## Step 3 – Top Wing

- Bolt top wing (C) to previously assembled partition as shown.
- Bolt on the flat side of the partition.
- Use 1/4" x 5/8" flanged hex head bolt and a 1/4" flanged nylock nut.
- Repeat for a total of 6 times.

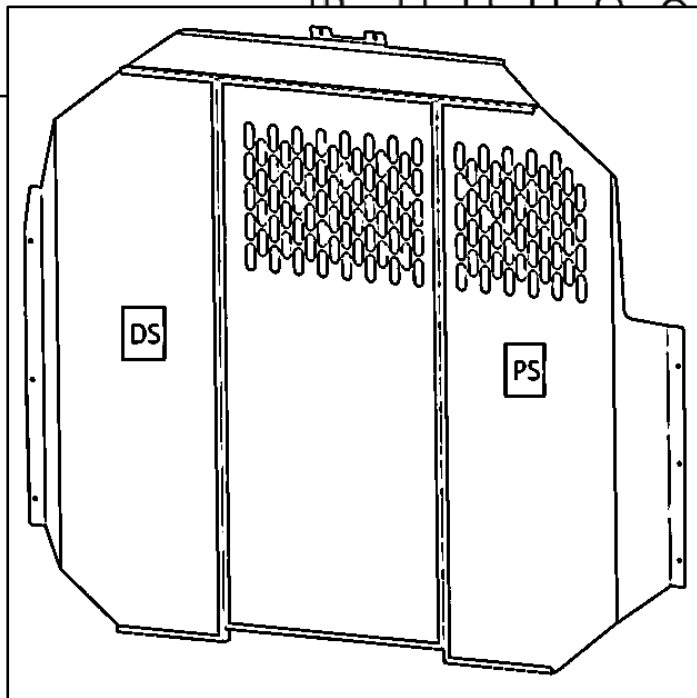
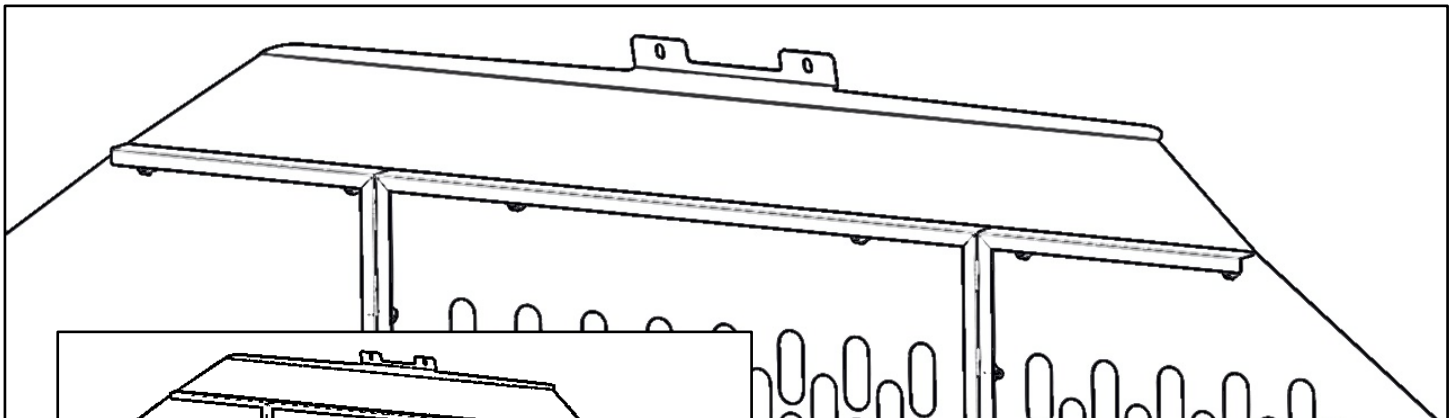
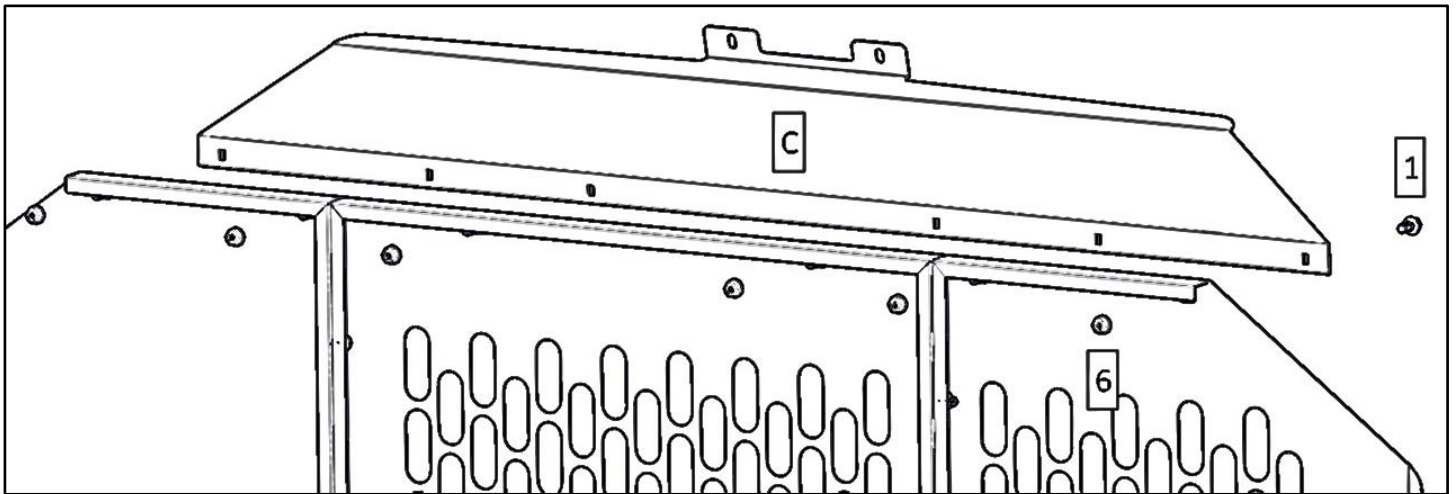

## **INSTALLATION**

### **Step 1 – Prepare to install Plus Nuts**

- Place assembled partition into van with the wings towards the “B” pillars.
- Press partition firmly against “B” pillars and the headliner across the roof of the van.
- Align and square partition.
- Mark the 3 holes on both side panels (A & C).
- Mark the two holes through the top wing (D) onto the headliner.
- Mark the 3 holes onto the floor through both side panels.
- There should be a total of 15 holes marked.

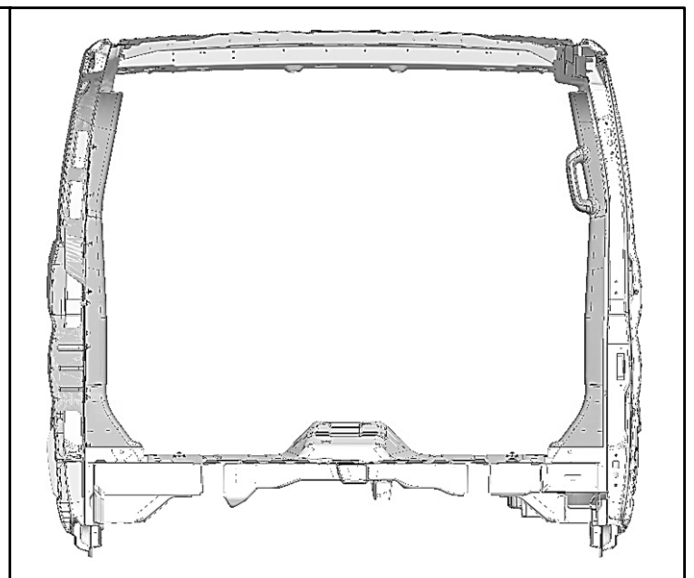
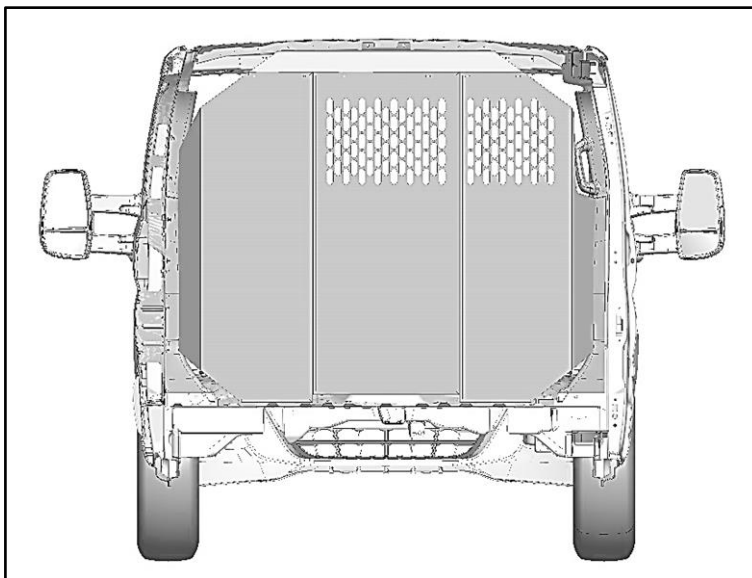
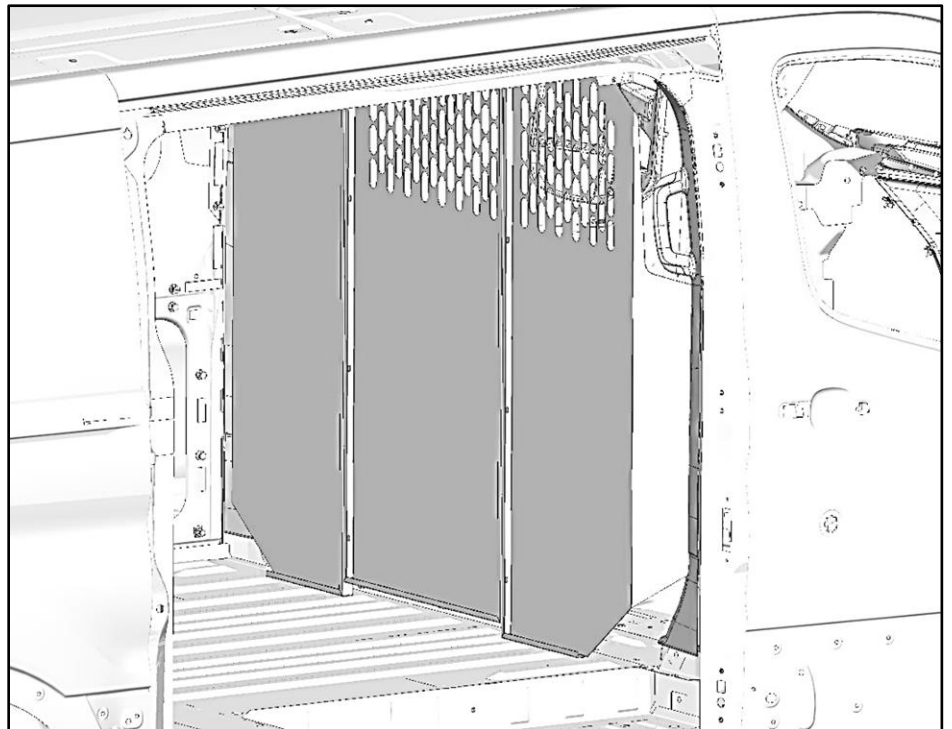



## Step 2 – Install Plus Nuts



**DO NOT drill beyond depth of floor or upper installation surface. Always check for wires, fuel tanks and lines, brake lines and other important vehicle functionality items prior to drilling and installing all products.**

- At each marked location, drill hole using 25/64" drill bit and appropriate sized drill-bit stop collar. If 25/64" drill bit is not available, a 3/8" drill bit can be used, although it may be necessary to tap in the plus nuts.
- Insert 1/4" x 2-1/4" hex head bolt through 1/4" flat washer and plus nut installation tool, and then screw bolt into plus nut. Knurled end of plus nut tool must be directed away from bolt head and contacting plus nut.
- Insert plus nut into hole with plus nut tool attached.
- Using the 9/16" box wrench, hold the plus nut tool stationary and then tighten hex head bolt until plus nut is tightly gripping and does not spin when hex bolt is loosened.
- DO NOT overtighten plus nut.
- Using the 9/16" box wrench, hold the plus nut tool stationary to remove the 1/4" hex head bolt.

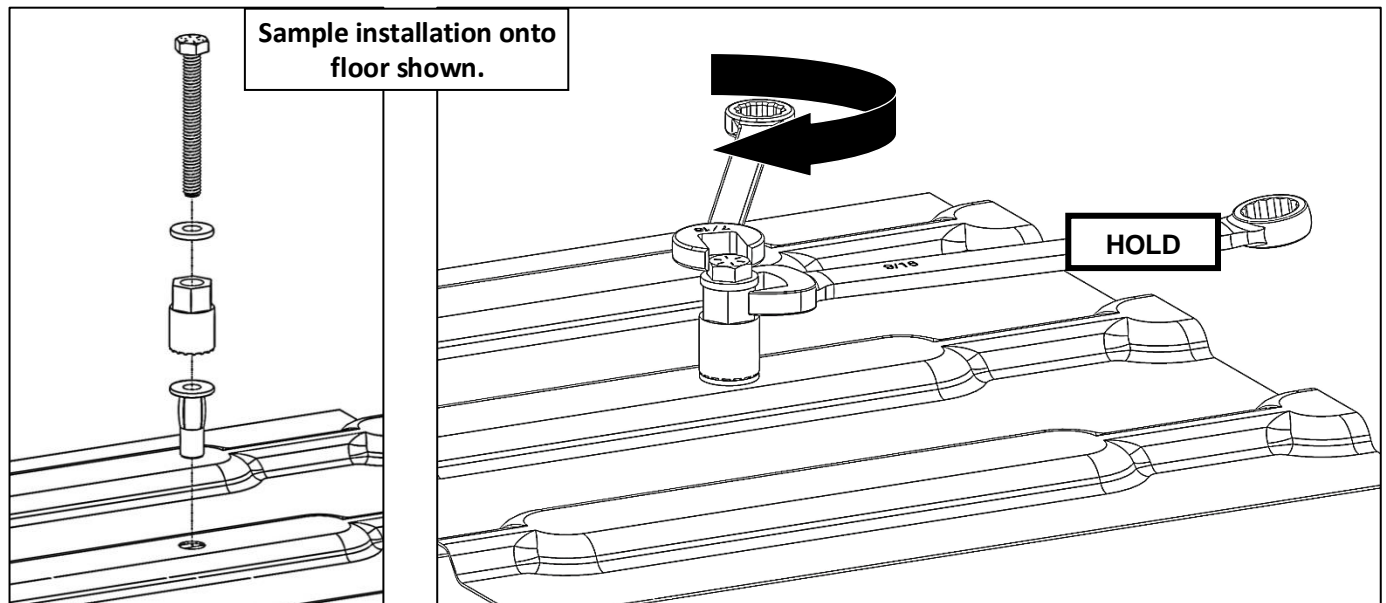

## Step 3 – Bolt Partition

- Place assembled partition back into van.
- Along the “B” pillars, bolt partition into previously installed Plus Nuts using a 1/4" x 1" hex head, a 1/4" split lock washer and a 1/4" flat washer.

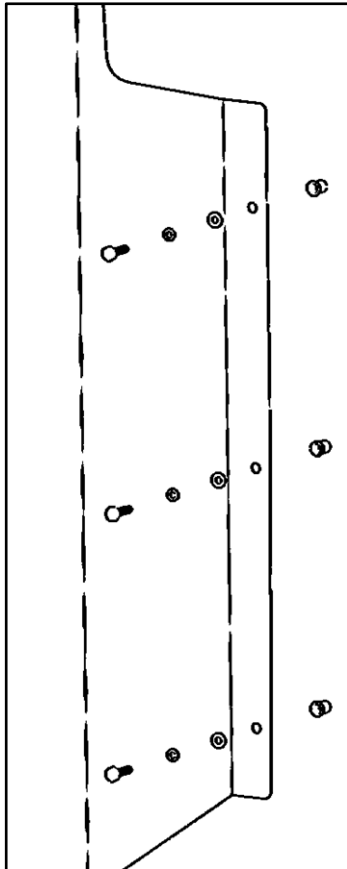

Passenger Side EXP

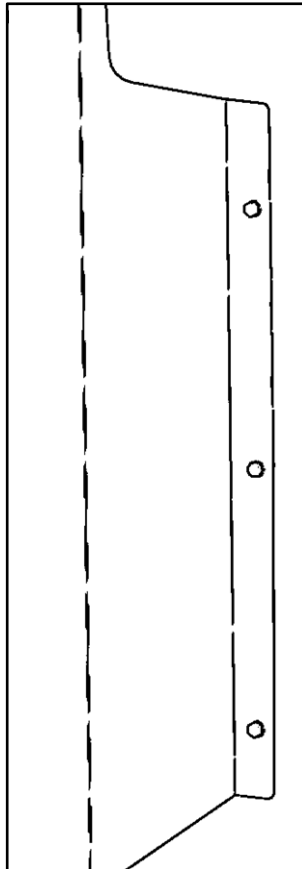

Passenger Side

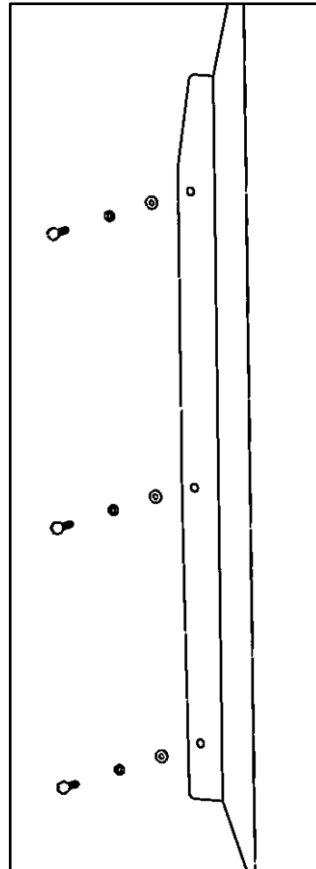

Driver Side EXP

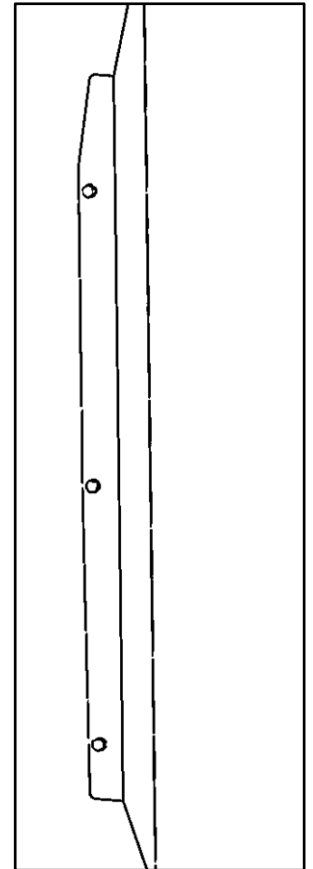

Driver Side

- Along the top wing, bolt partition into previously installed Plus Nuts using a 1/4" x 1" hex head, a 1/4" split lock washer and a 1/4" flat washer.

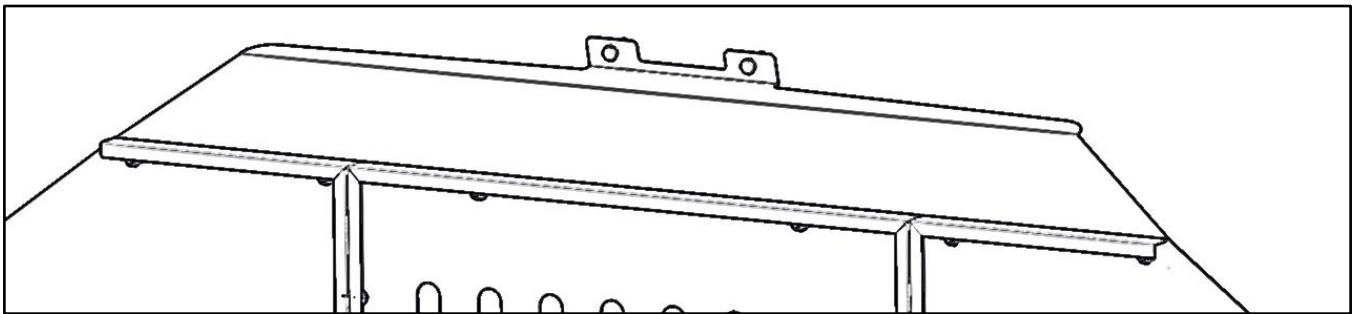
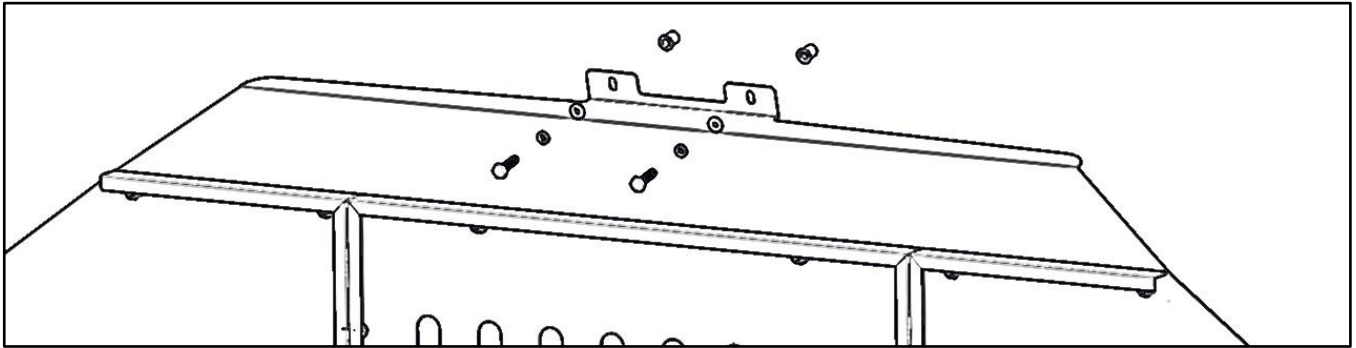

- Along the floor, bolt into Plus Nuts using 1/4" x 1-1/4" hex head bolt, a 1/4" split lock washer and a 1/4" flat washer. Place a 3/8" spacer where needed.

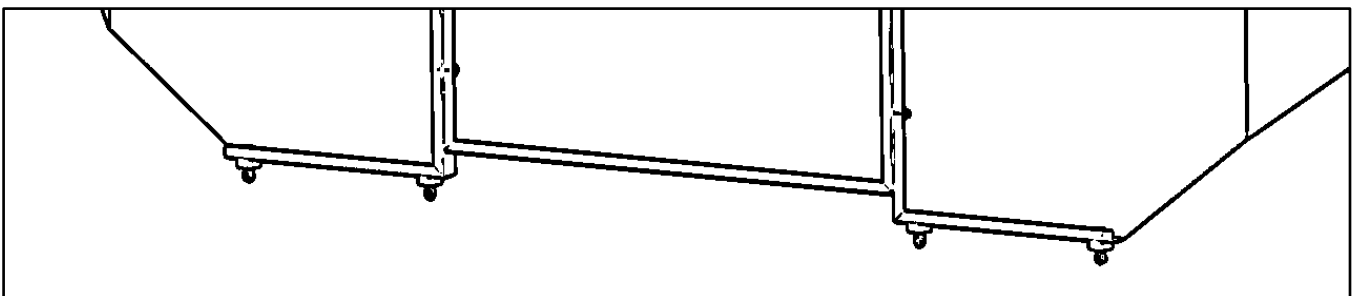
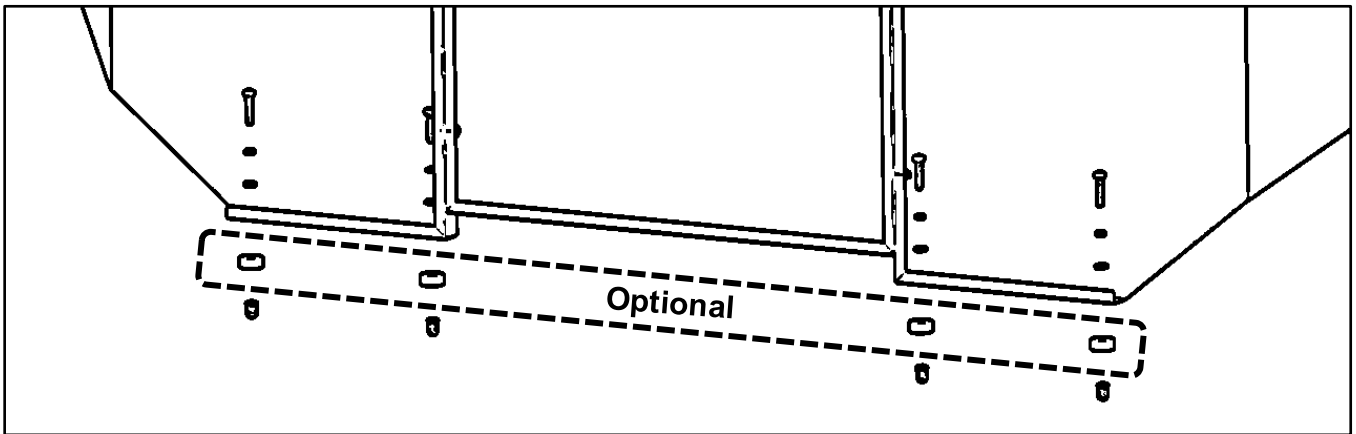

**TIGHTEN ALL BOLTS.**

**YOUR INSTALLATION IS NOW COMPLETE.**