

Holman

Assembly Guide 40943

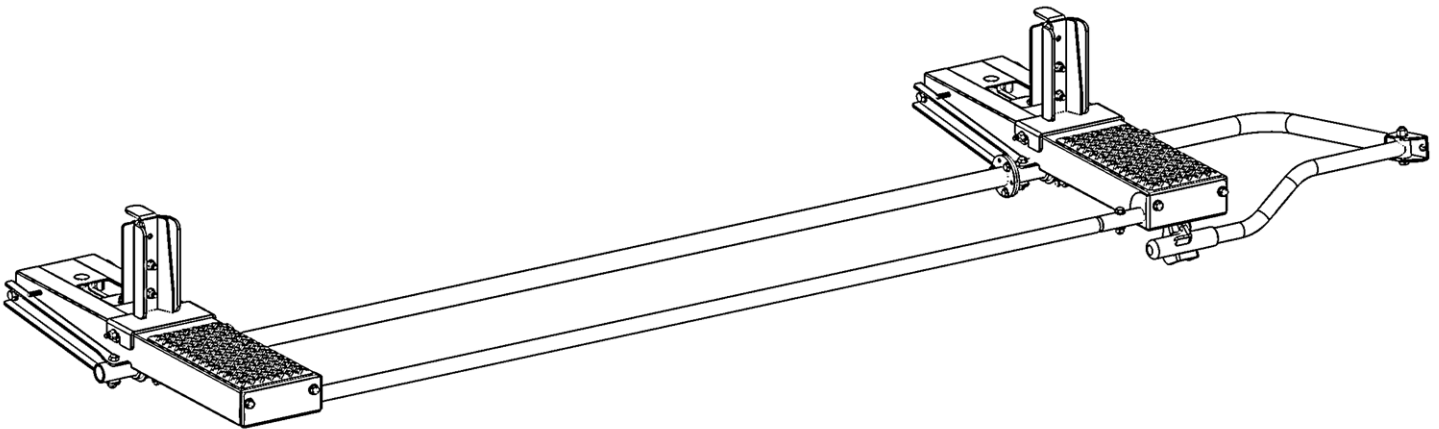

Holman
Rancho Cordova, CA 95742
800-343-7486
InstallationSupport@Holman.com

PLEASE READ ALL INSTRUCTIONS AND WARNINGS PRIOR TO ASSEMBLING, INSTALLING, AND USING THIS PRODUCT.

Warning



Always check for wires, fuel tanks and lines, brake lines and other important vehicle functionality items prior to drilling and installing all products.

Table of Contents

Tools Needed	1
Before You Begin	1
Parts List	2
Hardware	3
Step 1 – Determine Front and Rear Pan	4
Step 2 – Mount Cantilever Mechanism	5
Step 3 – Install Dampers	5
Step 4 – Install Latch Assembly	6
Step 5 – Install Rear Pan	7
Step 6 – Attach Handle	7
Step 7 – Install Front Mechanism	8
Step 8 – Install Front Pan	8
Step 9 – Install Torque Tube	9
Step 10 – Install Ladder Pan	9
Step 12 – Install Ladder Hooks	10
Step 13 – Ladder Stop	10

Tools Needed





7/16", 3/8", 1/2" Socket and Wrench

Tape Measure



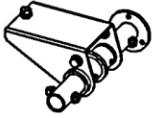
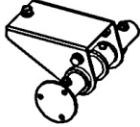
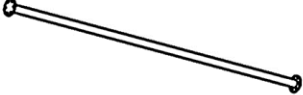
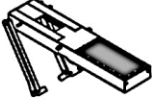
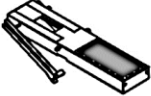
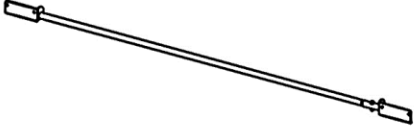

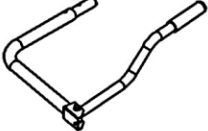
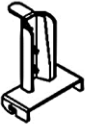

Before You Begin

- Read all instructions prior to assembling or installing any Holman product.
- Once rack is assembled, follow instructions included with mount kit to install the rack onto the vehicle.

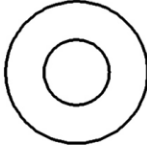
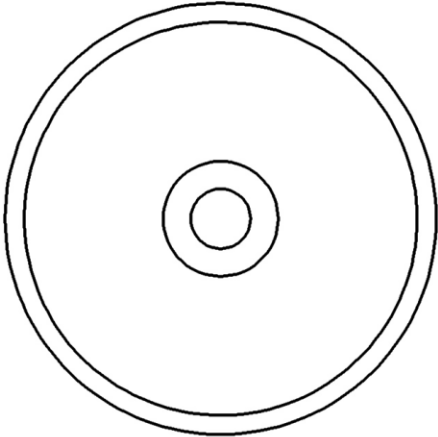
Parts List

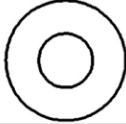
NO.	ITEM	PART NUMBER	DESCRIPTION	QTY.
1		40800-09	FRONT SHORT TORQUE TUBE ASSY	1
2		40800-08	REAR SHORT TORQUE TUBE ASSY	1
3		40800-21	TORQUE TUBE ASM	1
4		40800-05	REAR PAN ASSY	1
5		40800-06	FRONT PAN ASSY	1
6		40953-831	CROSSTUBE ASSEMBLY	1
7		40900-43	ASSEMBLY, HOOK, HANDLE, DROP DOWN, MINI	1
8		40943-43	OPERATOR ARM ASSEMBLY	1
9		40900-31	LADDER HOOK ASSY.	2
10		40900-30-004	LADDER STOP	2
11		18-00551	ASSEMBLY BOLT KIT	1

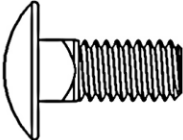
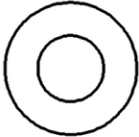
Hardware

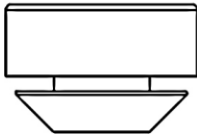
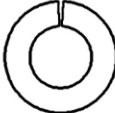
ITEM	HARDWARE TO SCALE	PART NUMBER	DESCRIPTION	QTY.
1		76063	3/8" X 1/16" C 3/4" NYLON WASHER	4
2			2.25 Wheel	4
3		13004	1/4"-20 X 7/8" HEX HEAD BOLT	6
4		33078	1/4" FLAT WASHER	12
5		37018	1/4"-20 NYLON INSERT LOCK NUT	6
6		21810	5/16"-18 X 3/4" CARRIAGE BOLT	2
7		33080	5/16" WASHER	6
8		0169777	5/16"-18 NYLOC	2
9			1"x5/16" Rubber Bumper	2
10		1133620	5/16" LOCKING WASHER	4

Hardware Cont.

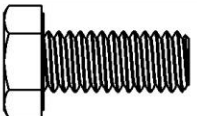
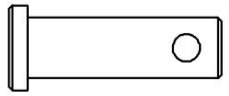
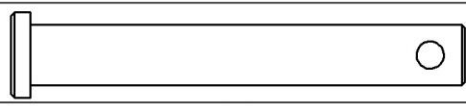
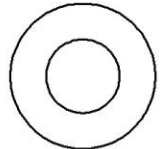
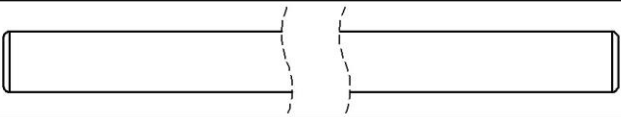
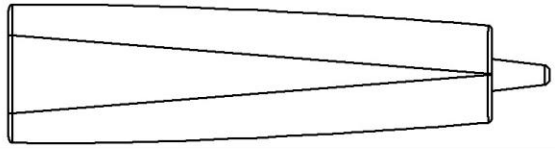
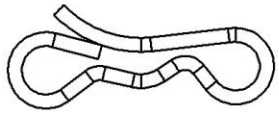
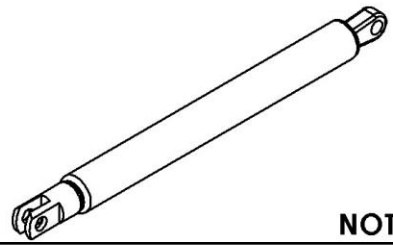
ITEM	HARDWARE TO SCALE	PART NUMBER	DESCRIPTION	QTY.
11		110120323	5/16-18 X 3/4" HEX HEAD BOLT	4
12		0156919	5/16" X 3/4" CLEVIS PIN	1
13		0156744	5/16" X 2" CLEVIS PIN	1
14		-	BUSHING, 3/8" ID, 3/4" OD, 1/2" LG, NYLON	2
15			Axle	2
16		BH-821	Self Leveling Adhesive Sealant	1
17		250 - 312 CTP Bow-Tie	Bow Tie Cotter Pins	2
18	 NOT TO SCALE.	AVM SD500	Damper - VEJPS190 "J" Orifice	1

Step 1 – Determine Front and Rear Pan

- The rear pan will have two bolts through one arm, while the front one will only have one on each arm.

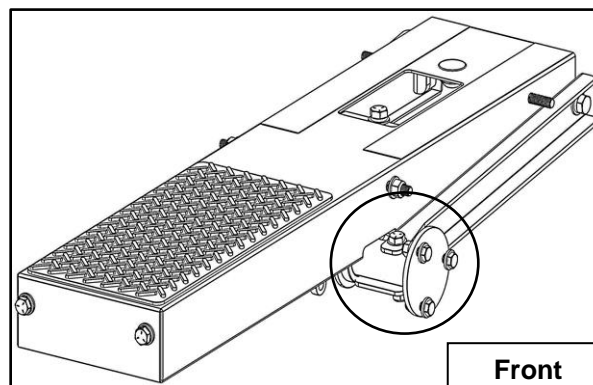
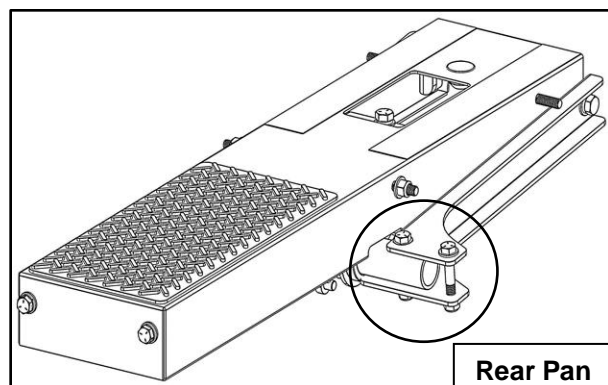

Step 2 – Install Rear Cantilever Mechanism

- Mount cantilever mechanism to the underside of the rear bow in the location shown using the pre-installed hardware on the torque tube assembly.
- **Be sure to have the flat-round piece towards the other bow assembly.**
- Snug tighten, but allow movement.

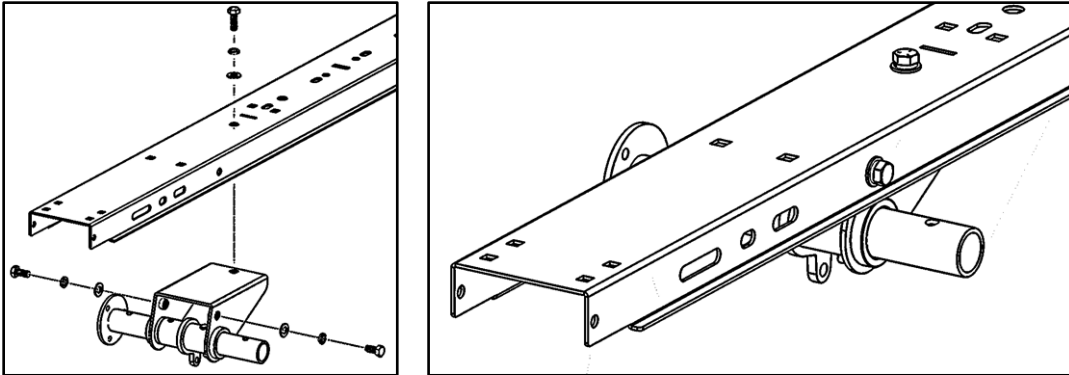

Step 3 – Install Dampers

- Install end of damper to damper mount using one 2" pin, one bow-tie cotter pin and two plastic spacers in orientation shown. **Be sure the damper is oriented as shown.**
- **Be sure bow tie cotter pins are properly installed to ensure the 2" pins securing the damper stay in place.**

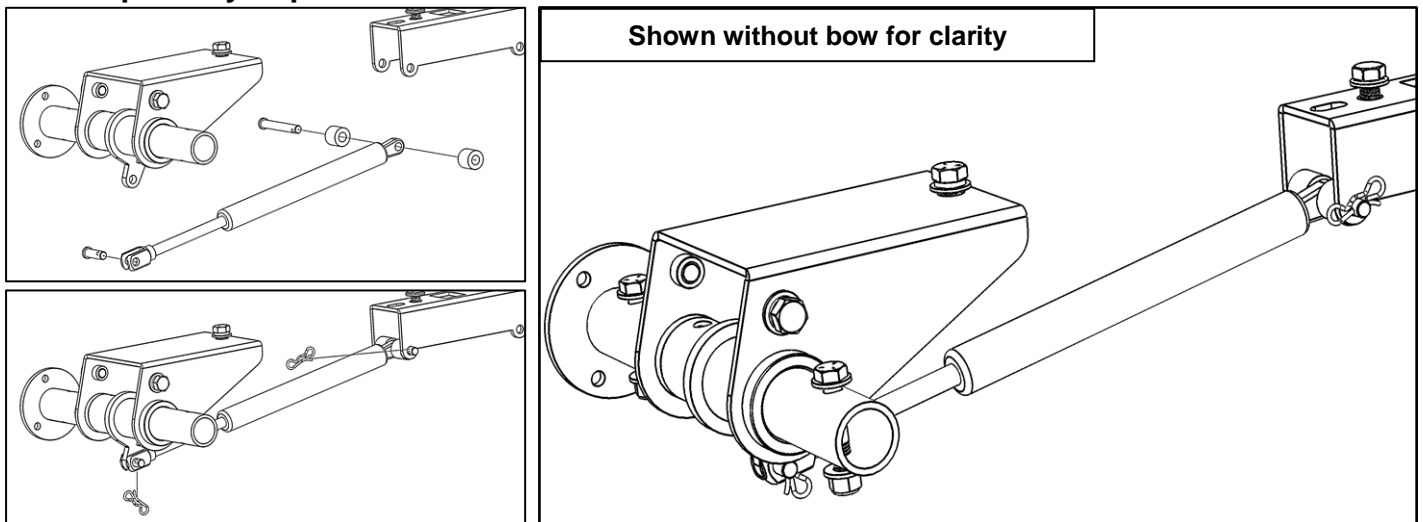

Note: In some situations, you may be easier to wait until handle assembly is installed to attach both ends of the damper. This is so you can use the handle to help shorten the distance between the two ends the damper.

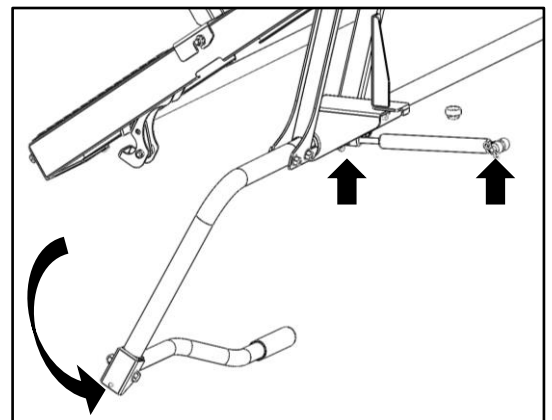

Step 4 – Install Latch Assembly

- Install latch assembly to the driver side end of the rear bow.
- Using two 5/16" x 3/4" carriage bolts, two 5/16" flat washers, and two 5/16" lock nuts, install latch assembly to second set of holes in the exposed end of the rear bow, in the orientation shown below. **Be sure to use the second set of holes nearest the center of the bow, and NOT the outer most holes.**

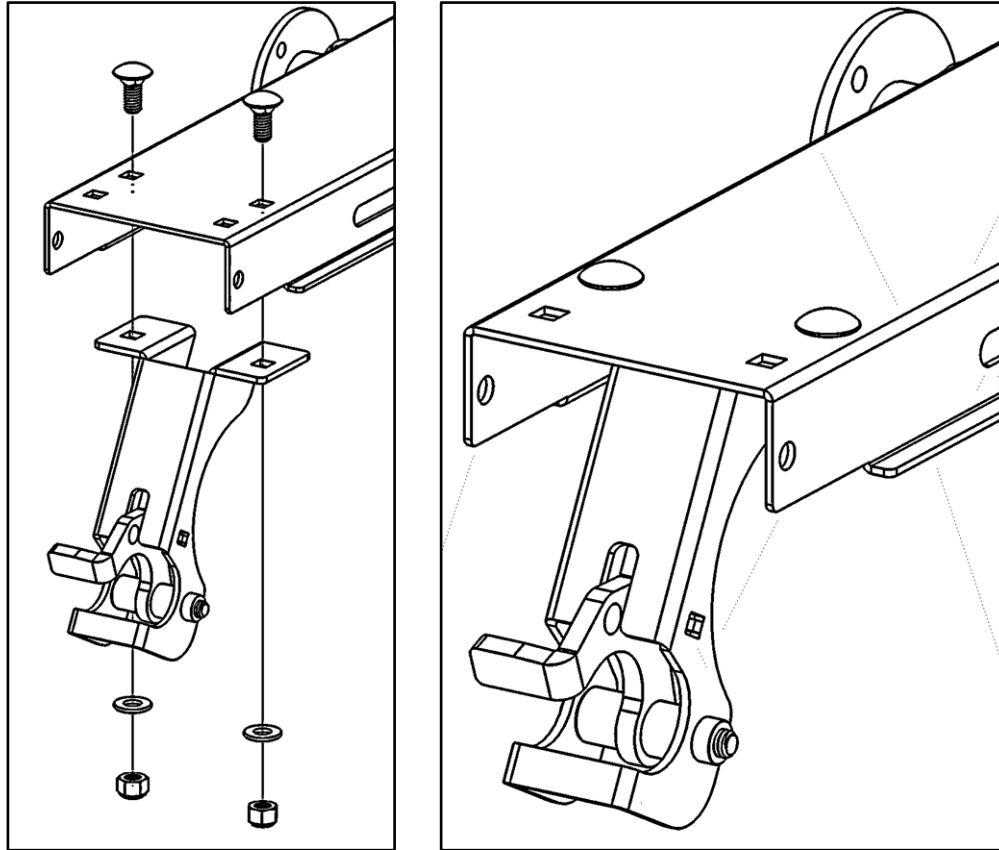

Step 5 – Install Wheel Assembly

- Slide wheel axle in the end of the rear bow. Place a wheel on each end of the axle.

NOTE: WHEN INSTALLING PAN, BE SURE THE WHEEL CAP STOPPER STAYS IN PLACE.

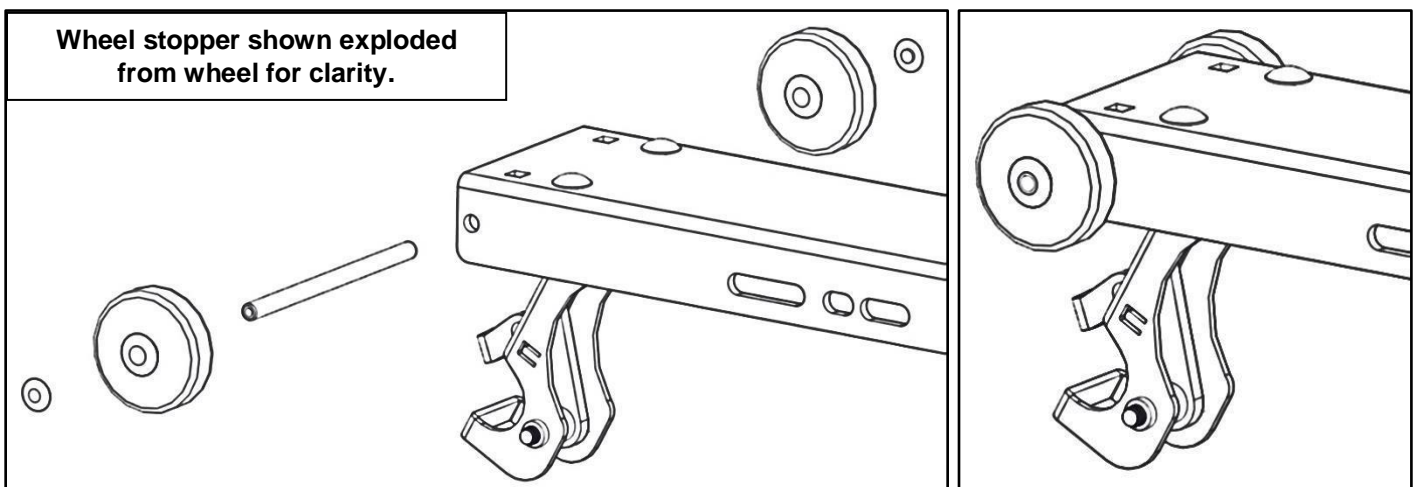

Step 6 – Install Rear Pan

- Remove the pre-installed two 5/16" x 2" hex head bolts, four 3/8" washers, and two 5/16" lock nuts from cantilever assembly.
- With the pan at an angle place the pan over the wheels and slide into place. **Be sure the wheel caps do NOT come off.**
- Align the holes on the pan arms to the holes on the cantilever mechanism and reinstall the removed hardware ONLY on the front side of the mechanism where the torque tube will attach. Leave the holes on the other side empty, as they will be filled when installing the handle.

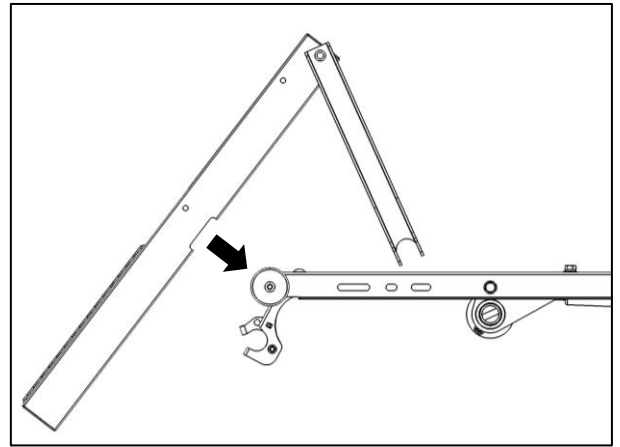

Note: Hold onto the other 5/16" x 2" hex head bolt, two 3/8" washers, and 5/16" lock nut as they will be used later when installing the handle.

- Snug tighten, but allow movement.

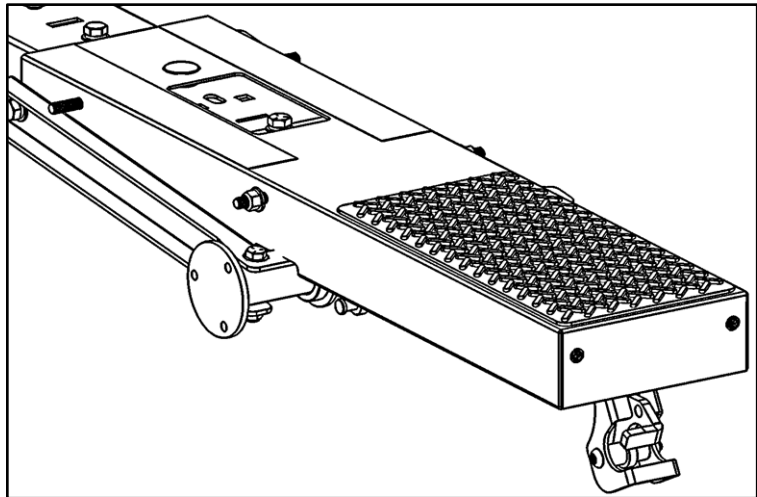
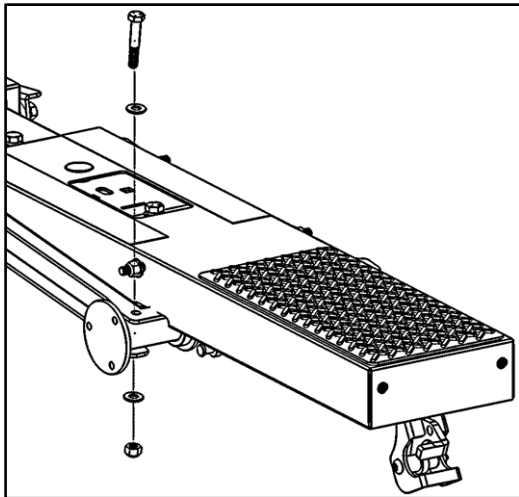

Step 7 – Attach Handle

- Attach handle to rear pan using hardware removed in previous step.
- TIGHTEN.

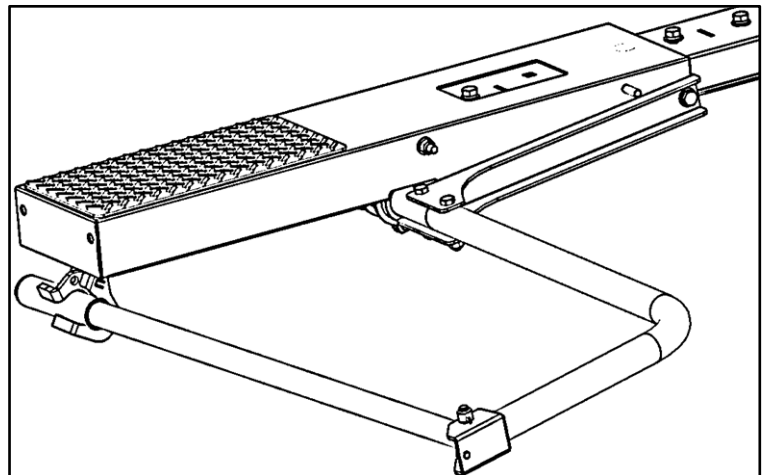
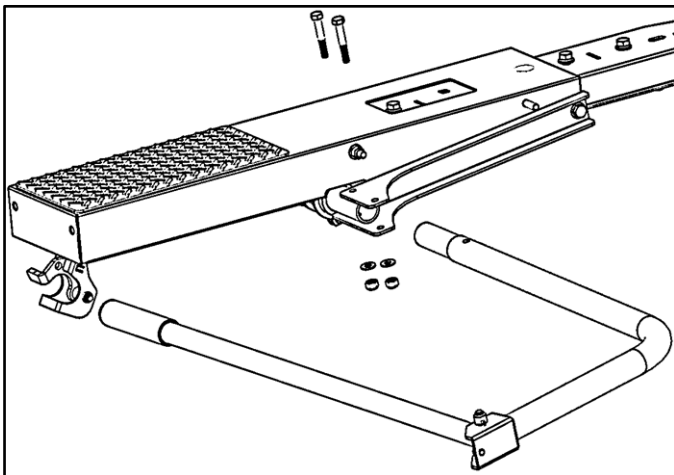

Step 8 – Install Front Cantilever Mechanism

- Mount cantilever mechanism to the underside of the front bow in the location shown using the pre-installed hardware on the torque tube assembly.
- **Be sure to have the round part of the mechanism towards the rear bow.**
- Snug tighten, but allow movement.

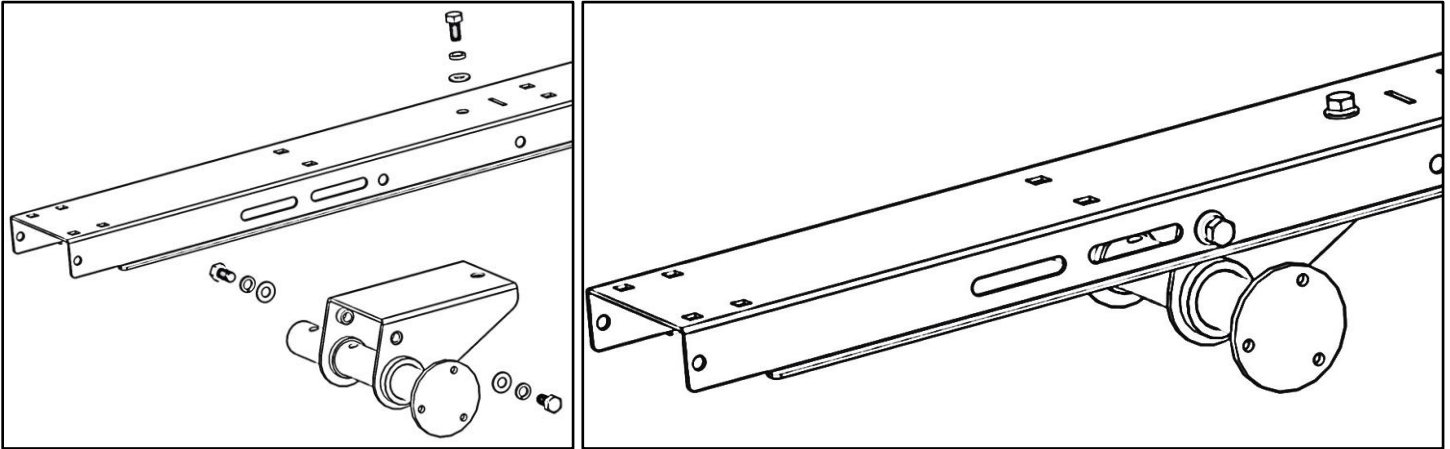

Step 9 – Install Front Pan

- Remove the pre-installed two 5/16" x 2" hex head bolts, four 3/8" washers, and two 5/16" lock nuts from cantilever assembly.
- Place front pan on to the front bow using the same method described in step 6 for the rear bow.
- Bolt pan arms to cantilever housing using removed bolts.
- Snug tighten, but allow movement.

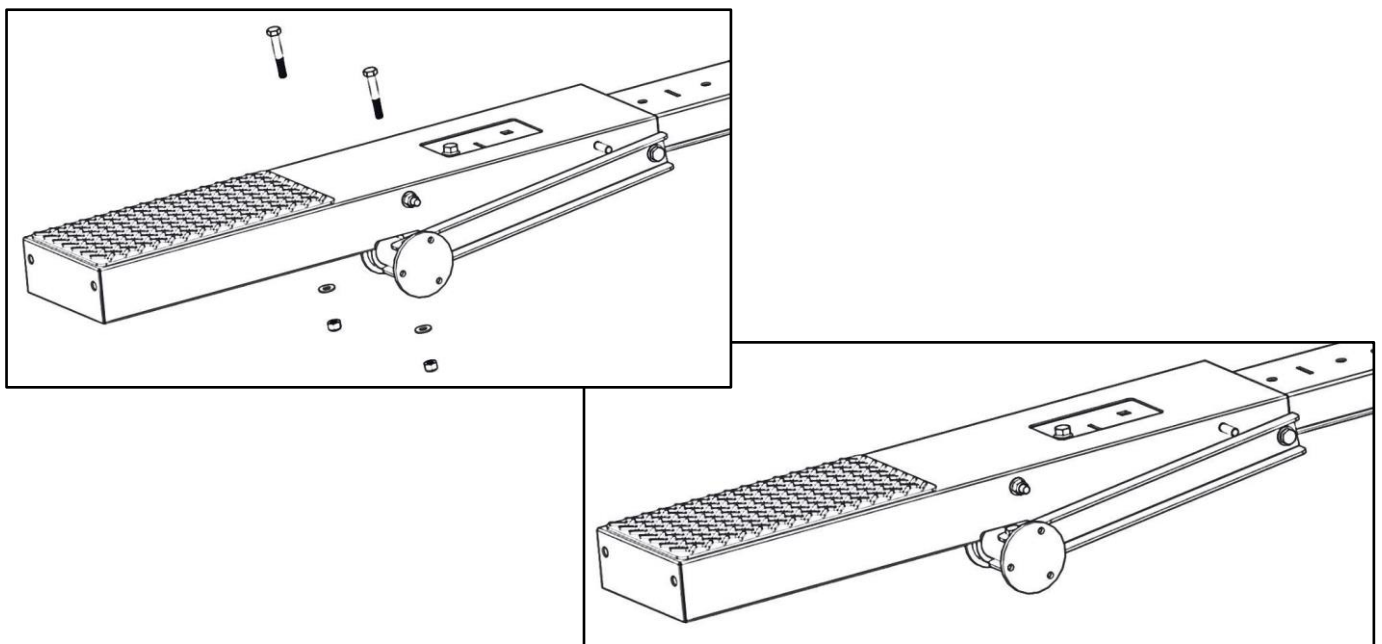

Step 10 – Install Torque Tube

- Using three 1/4" x 7/8" hex head bolts, three 1/4" flat washers and three 1/4" lock nuts, bolt the torque tube to front pan assembly.

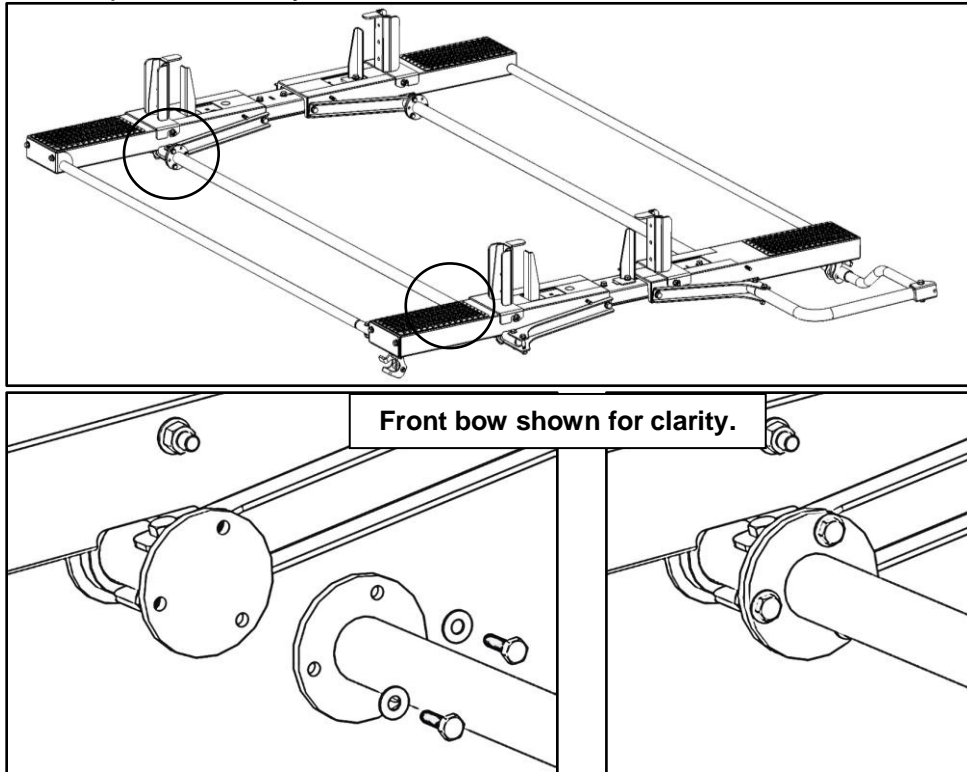

- Repeat at both front and rear bows.
- TIGHTEN.

Step 11 – Install Ladder Pan

- Attach pan support to both front and rear bow using four 5/16" x 5/8" hex head bolts, four 5/16" split lock washers, and four 5/16" flat washers.
- TIGHTEN.

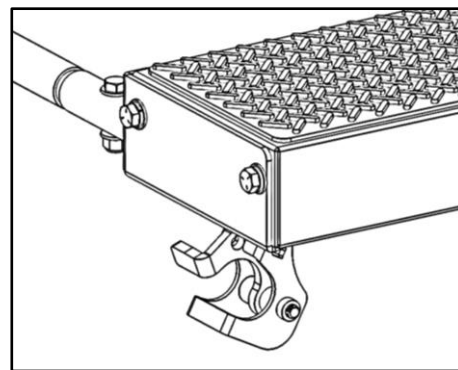
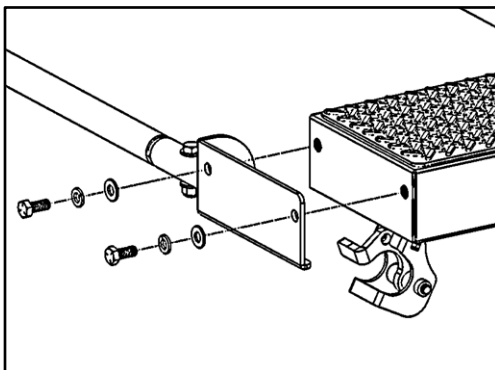
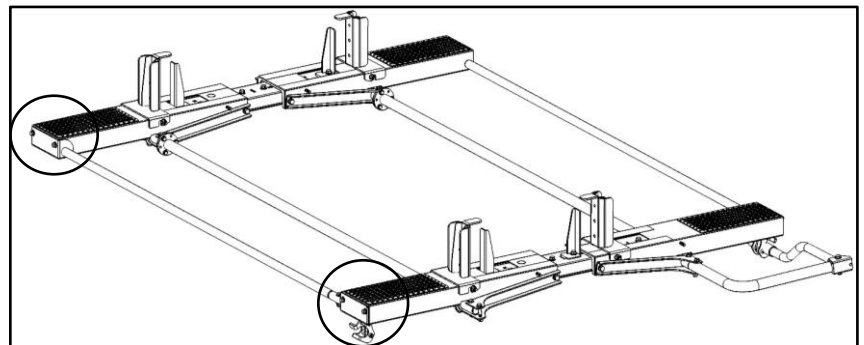

Step 13 – Install Ladder Hooks

- Using the pre-installed hardware and installed studs on the bows, loosen nuts and slide ladder hook into place.
- There are two sets of studs attached to the pans, use appropriate set depending on what ladder you are using.
- **TIGHTEN.** Be sure to tighten by hand do not use an impact gun.

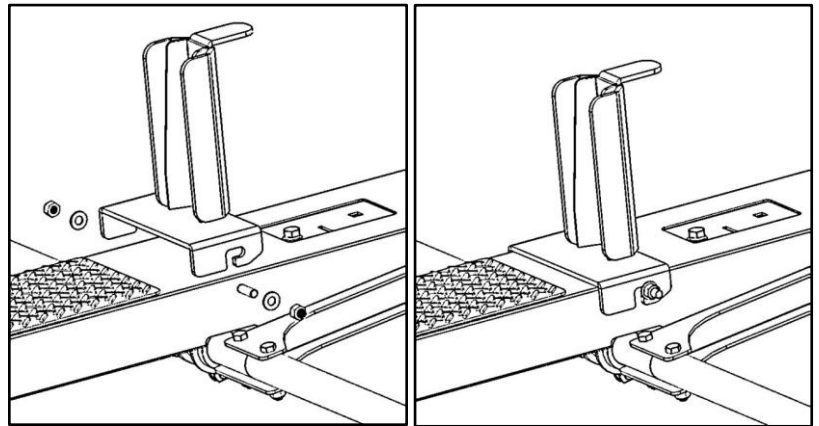

Step 14 – Ladder Stop

- Using the pre-installed hardware on the bows, bolt the ladder stop in the orientation shown. **Be sure to line up slot in bow with slot in stop.**
- **TIGHTEN.**

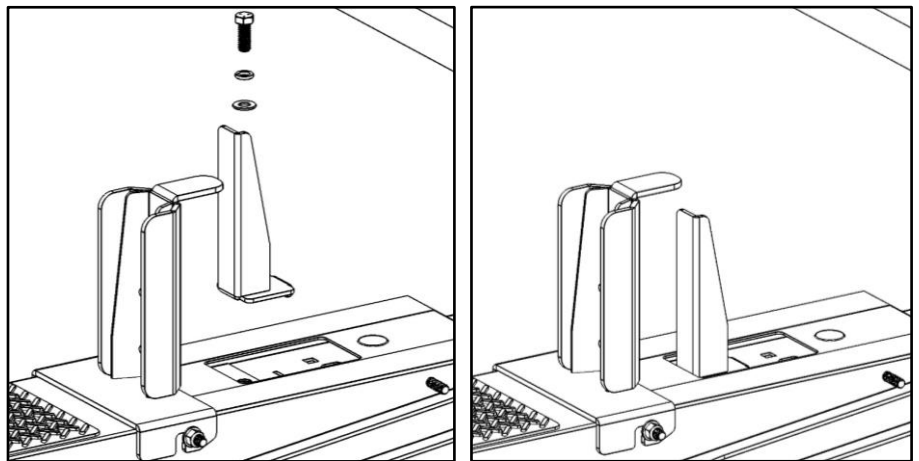

GO BACK AND TIGHTEN ALL HARDWARE.

ASSEMBLY IS COMPLETE.

