

# Holman

---

## Instruction Guide 40983

---

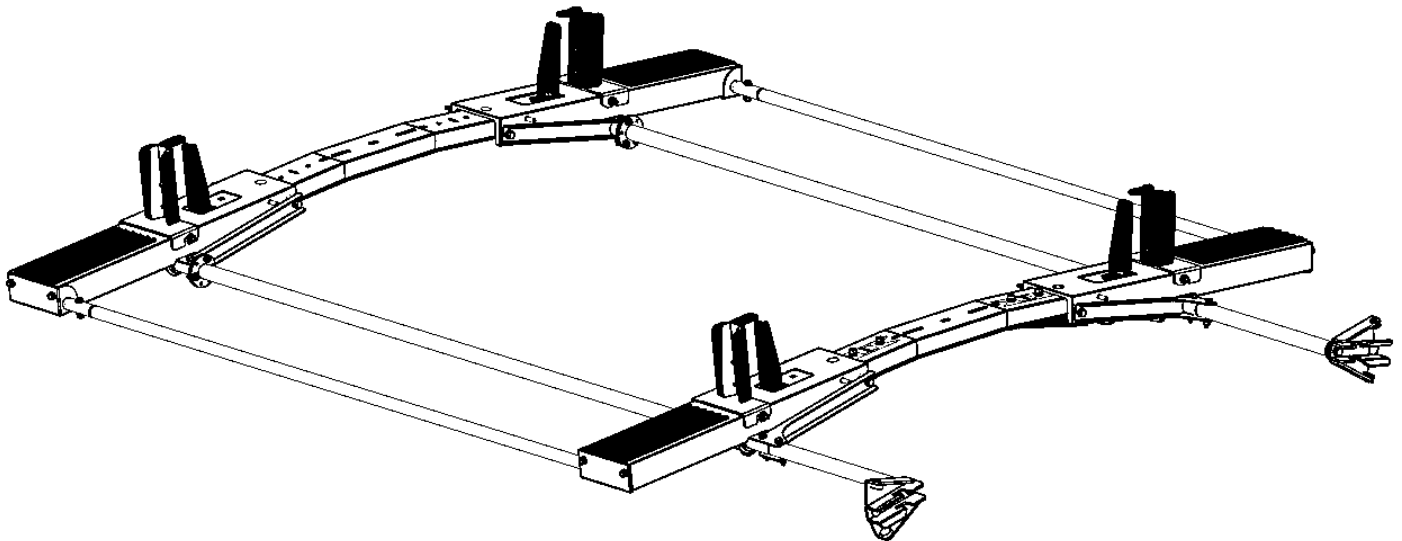

---

Holman  
Rancho Cordova, CA 95742  
800-343-7486  
[InstallationSupport@Holman.com](mailto:InstallationSupport@Holman.com)

**PLEASE READ ALL INSTRUCTIONS AND WARNINGS PRIOR TO ASSEMBLING, INSTALLING, AND USING THIS PRODUCT.**

## Warning

 **Always check for wires, fuel tanks and lines, brake lines and other important vehicle functionality items prior to drilling and installing all products.**

## Tools Needed

7/16" Socket and Wrench	1/2" Socket and Wrench
9/16" Socket and Wrench	



## Contents

Parts .....	3
Hardware .....	4
Step 1 – Remove Bow Stops .....	5
Step 2 – Install Rubber Bumper .....	5
Step 3 – Install Rear Damper Mechanism .....	6
Step 4 – Install Rear Wheels .....	7
Step 5 – Install Rear Pan .....	8
Step 6 – Install Front Mechanism .....	9
Step 7 – Install Front Wheels .....	10
Step 8 – Install Front Pan .....	11
Step 9 – Install Torque Tube .....	12
Step 10 – Install End Tube .....	13
Step 11 – Install Ladder Hooks .....	14
Step 12 – Install Ladder Stops .....	17
Step 13 – Install Handle Mechanism .....	18
Step 14 – Use Handle .....	19



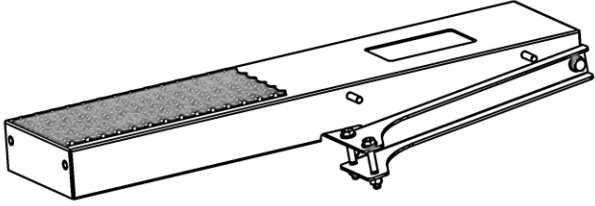
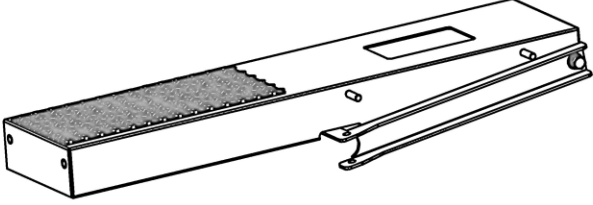
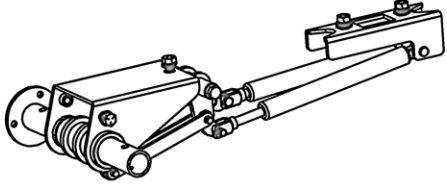
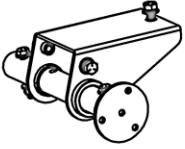
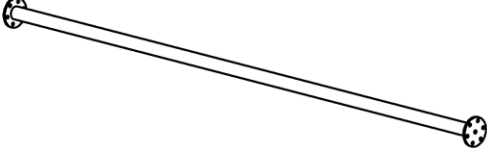
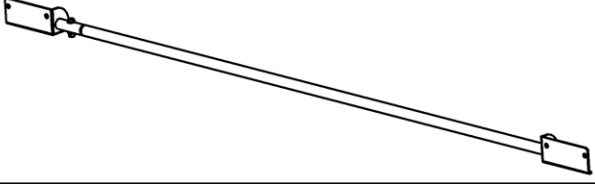
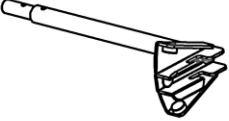

## Before You Begin

- Read all instructions.
- Be sure to have ladder rack installed on vehicle. This kit is a driver side addition.
- **DO NOT EXCEED MANUFACTURERS WEIGHT CAPACITY FOR ROOF.**

## Parts

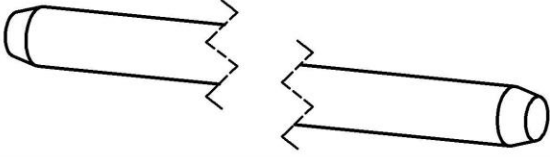
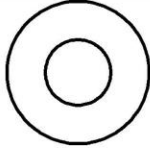
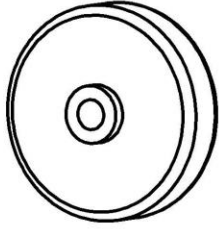
ITEM NO.		PART NUMBER	DESCRIPTION	QTY.
1		40800-05	REAR PAN	1
2		40800-06	FRONT PAN	1
3		40800-15	REAR DAMPER MECHANISM	1
4		40800-09	FRONT MECHANISM	1
5		40800-21	TORQUE TUBE	1
6		40953-831	END TUBE	1
7		40800-10	HANDLE MECHANISM	1
8		40900-30-004	LADDER STOP	2
9		40900-31	LADDER HOOK ASM	2
		18-00802	HARDWARE KIT	1

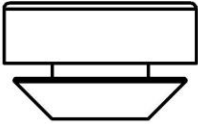
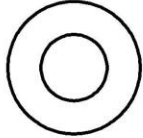
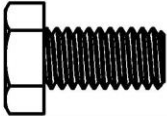
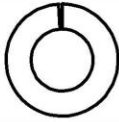
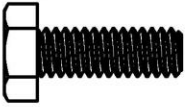
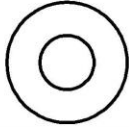
## Hardware

ITEM NO.	TO SCALE	PART NUMBER	DESCRIPTION	QTY.
1		40800-10-005	Axle	2
2		90295A160	3/8 Nylon Washer	4
3		9960T26-Wheel	Wheel Scale 1:2	4
4		9960T26-Cap	Wheel Cap	4
5		9309k19	Rubber Bumper	2
6		90126A030	5/16" Flat Washer	4
7		92865A580	5/16"-18 x 5/8" Hex Bolt	4
8		91102A755	5/16" Split Lock Washer	4
9		92865A540	1/4"-20 X 7/8" Hex Bolt	6
10		90126A029	1/4" Flat Washer	12
11		95615A120	1/4" Nyloc	6
		60ML SEALANT	SEALANT	1

## **Step 1 – Remove Bow Stops**

- If installed, remove the bow stops from the end of each bow on the drivers' side of the ladder rack.

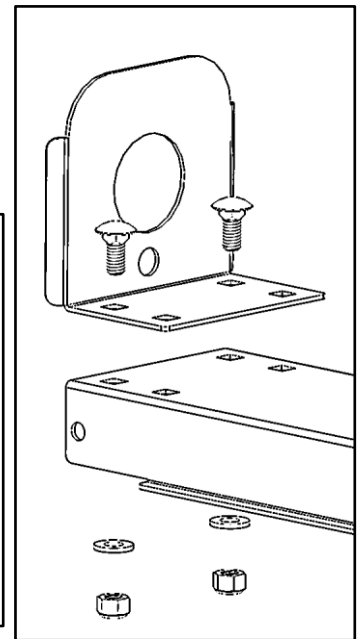
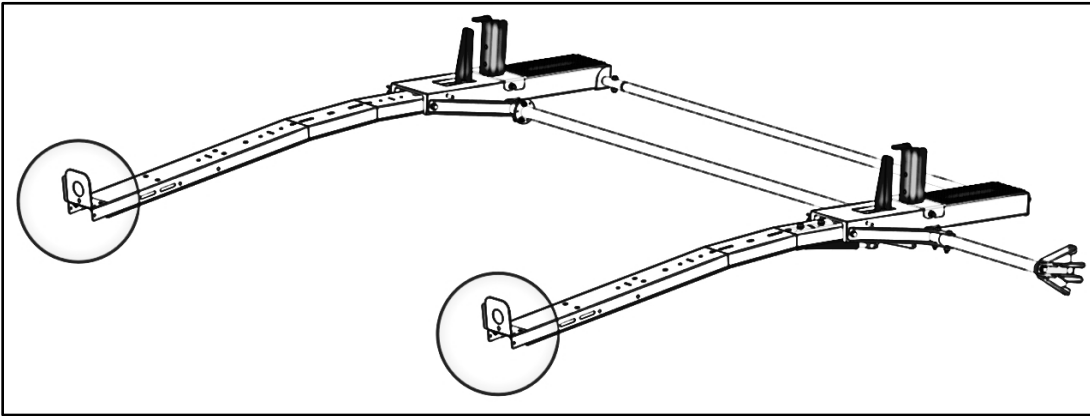

## **Step 2 – Install Rubber Bumper**

- Install the rubber bumper in the large round hole on each bow in the location shown below. These rubber bumpers push into place.

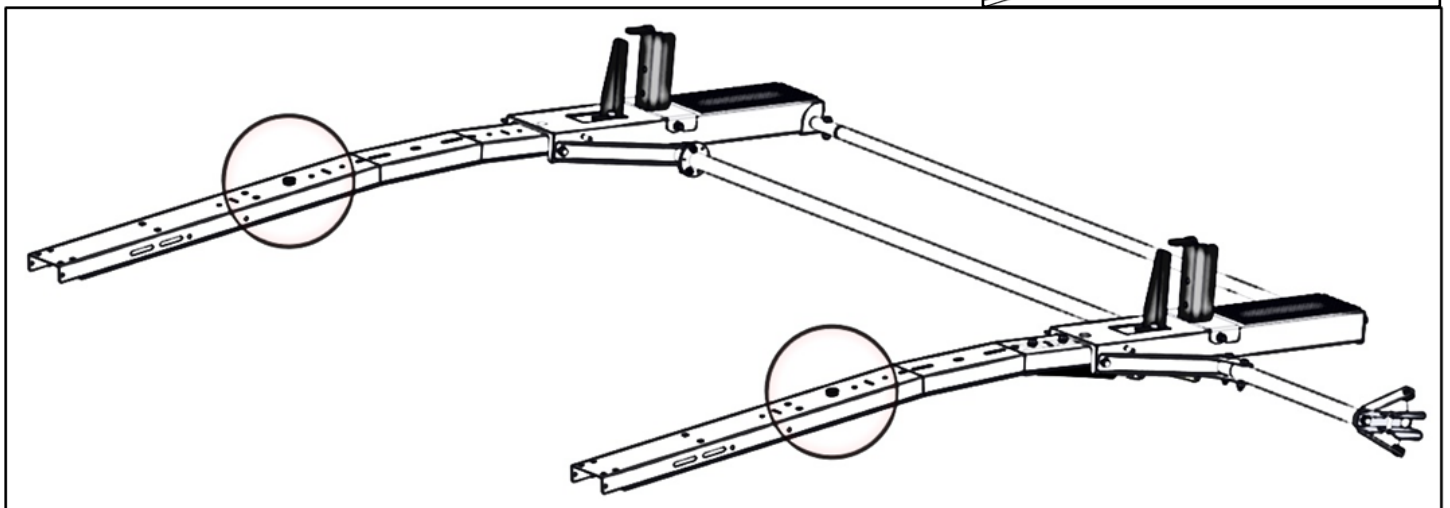
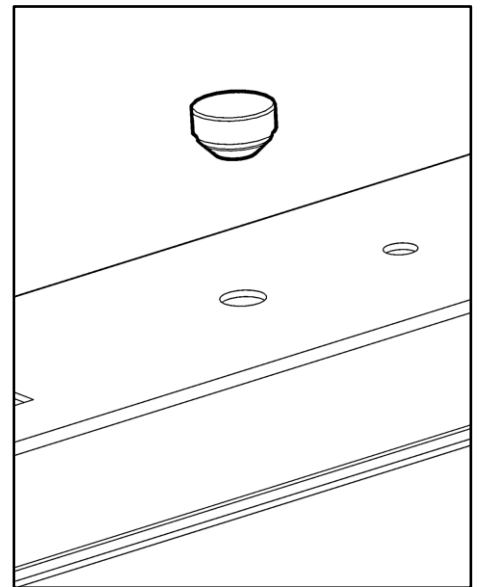

## Step 3 – Install Rear Damper Mechanism

- Mount the rear bow damping mechanism to the underside of the rear bow in the locations shown. Use the hardware pre assembled in the damping mechanism to attach to the bow.
- The damper may need to be removed to attach all necessary hardware. The damper can be re-attached once the rack is complete and the handle can be used as leverage.
- TIGHTEN.

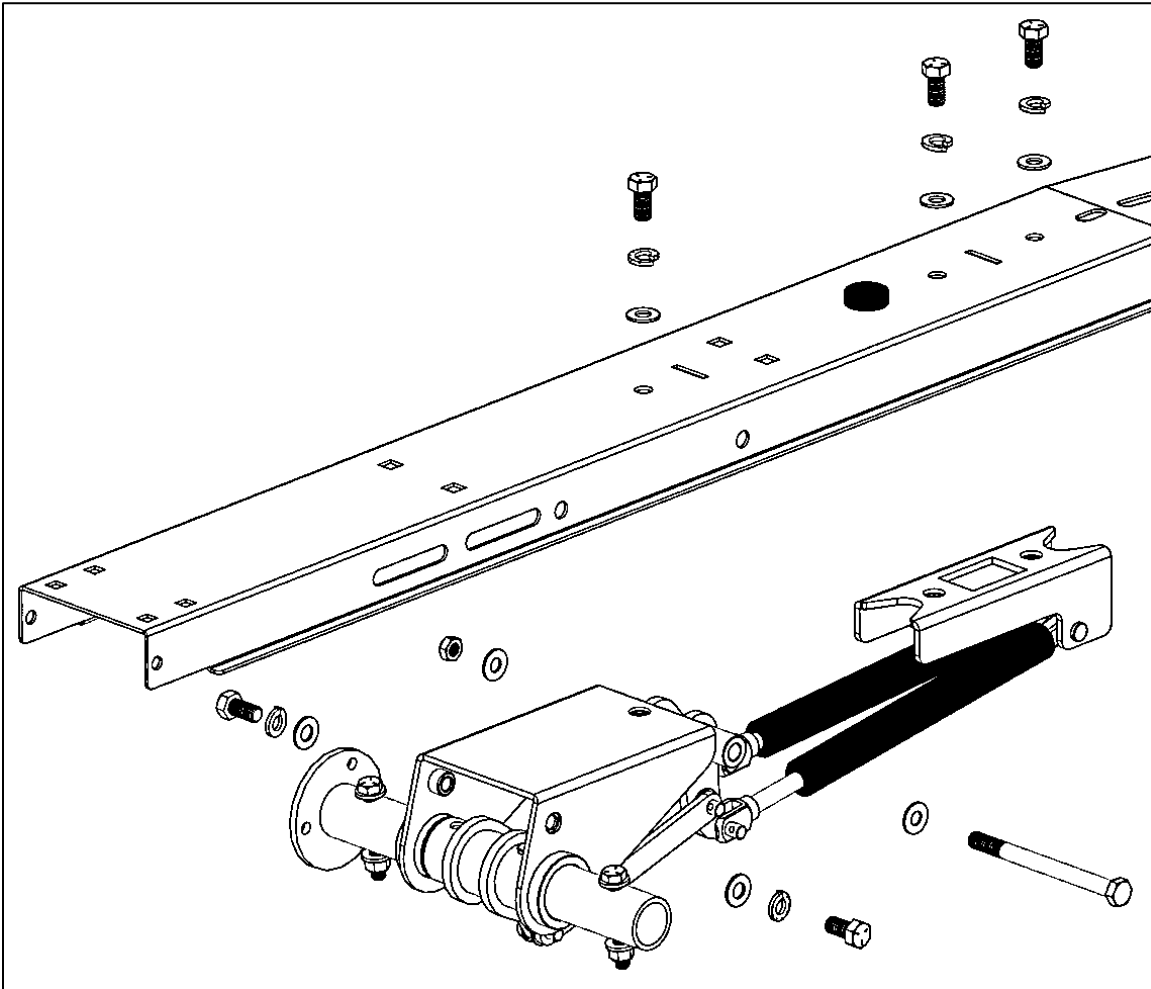

- While installing the 3/8" x 4-1/2" hex head bolt, **be sure to NOT lose the pre-assembled nylon washers.** These nylon washers go to the inside of the bow.

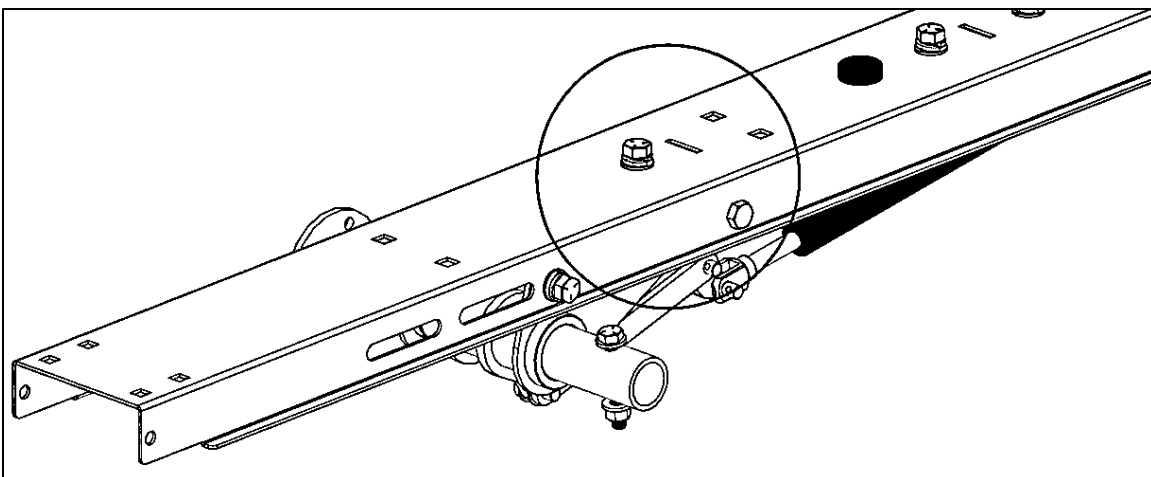

## **Step 4 – Install Rear Wheels**

- Slide the wheel axle through the holes at the end of the bow.
- Place a nylon washer on the axle against the outside of the bow.
- Place a wheel at each end of the axle, one on each side of the bow.
- Cap each wheel with a wheel cap.

**WHILE PLACING THE PAN IN THE NEXT STEP, BE SURE THE WHEEL CAPS DO NOT COME OFF.**

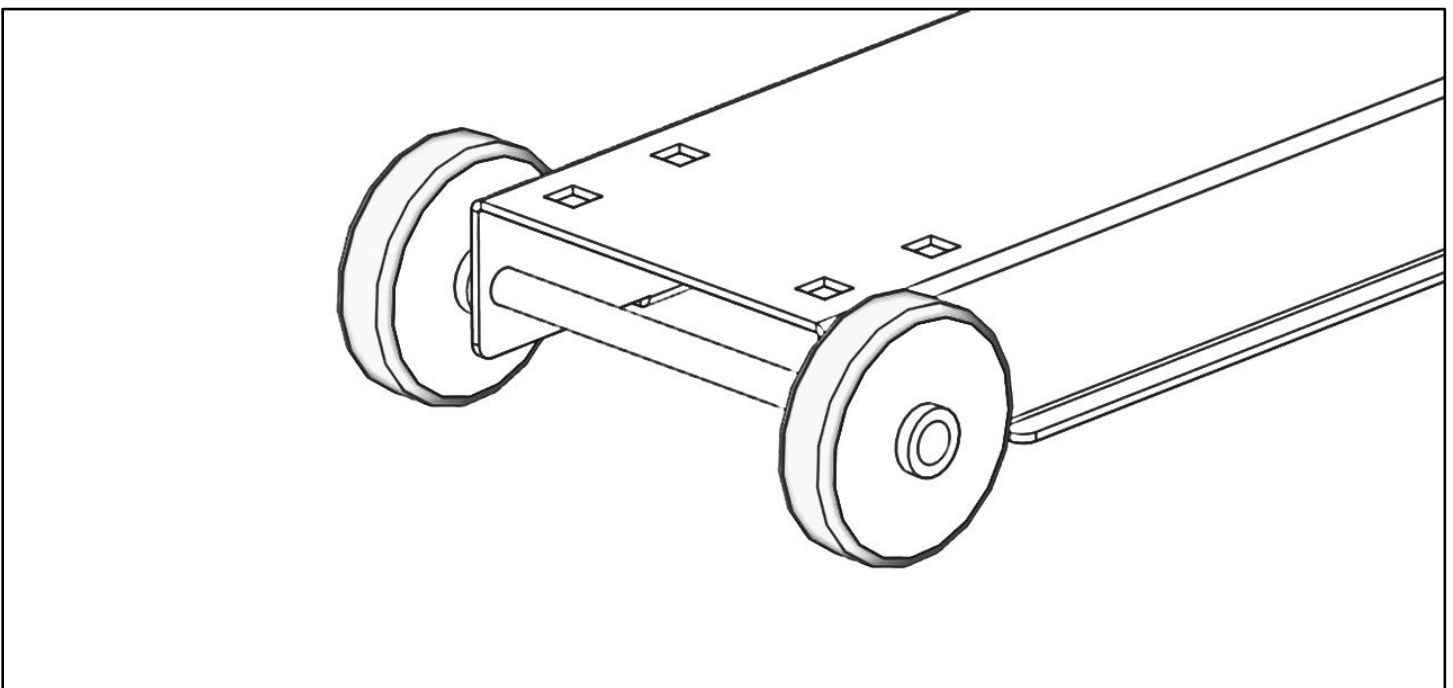
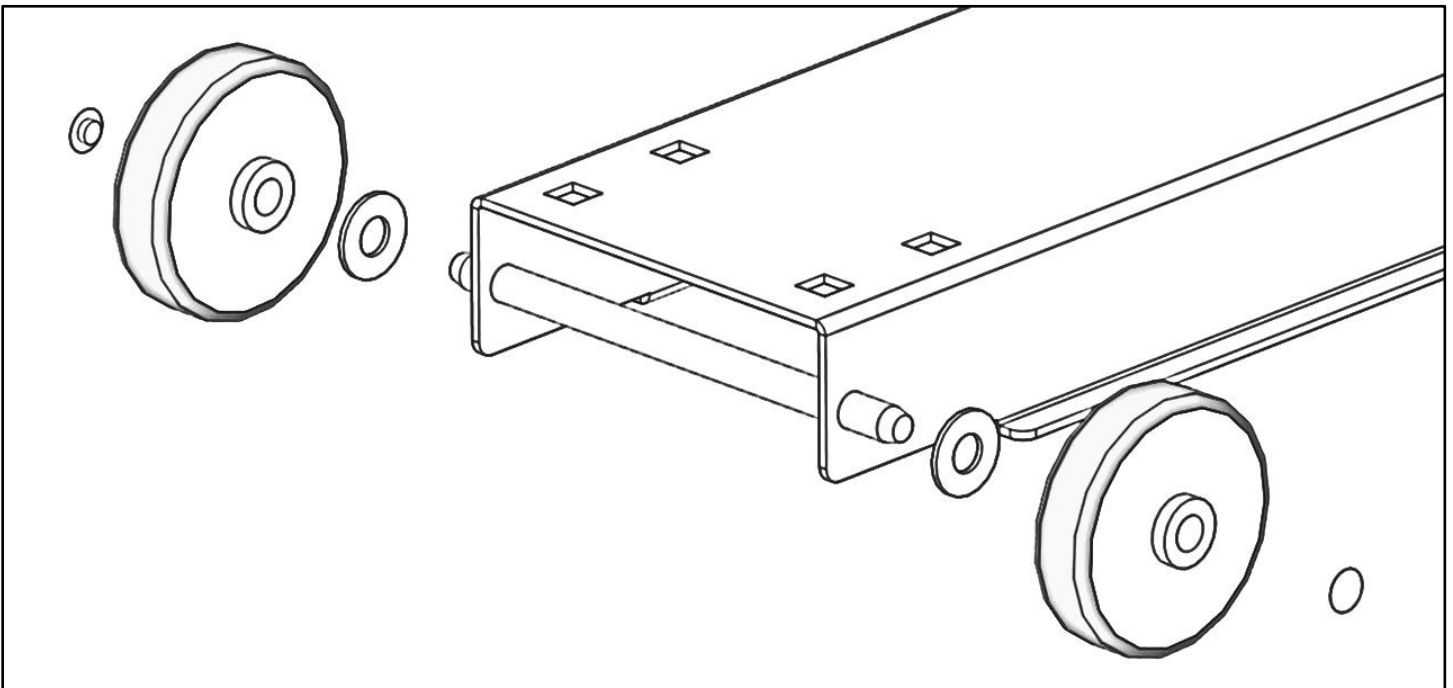

## Step 5 – Install Rear Pan

- Identify the rear pan assembly, it will have two mounting locations on one of the arms as shown.

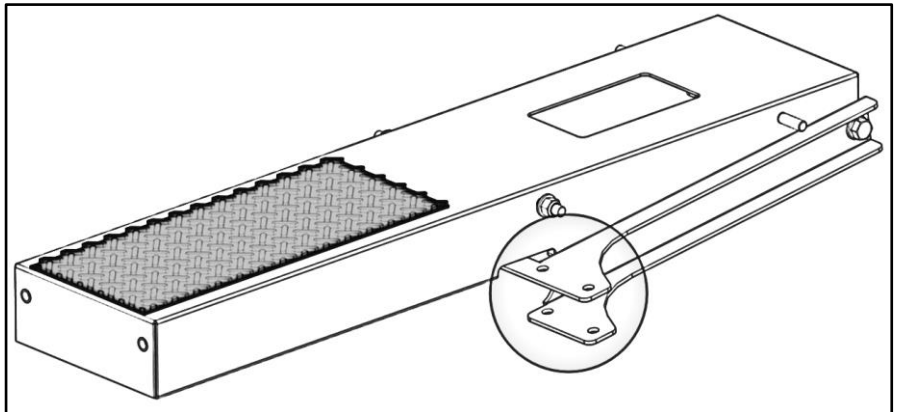

- Remove the pre-installed hardware from the damper mechanism.

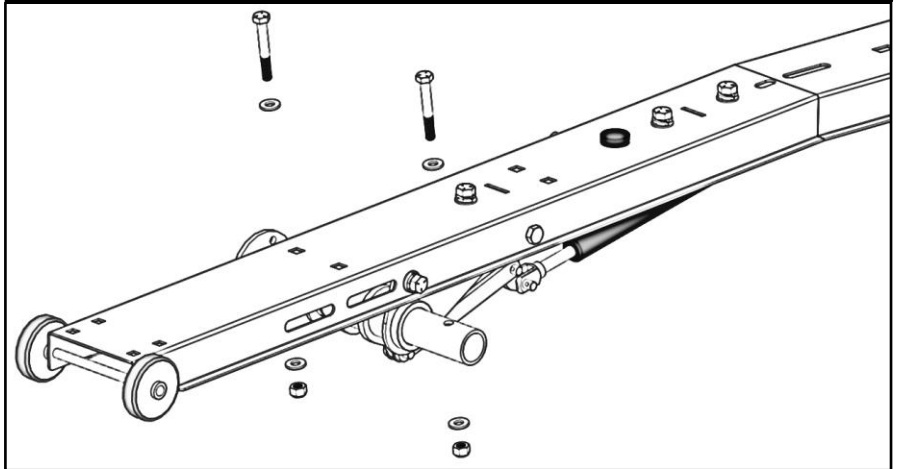

- Place the rear pan on top of the wheels and bow. **BE SURE THE WHEEL CAPS DID NOT COME OFF.**

- Align the arms from the rear pan with the holes in the tube on the damper mechanism where the previous hardware was removed.

- Bolt **ONLY** the front side of the rear pan assembly to the tube using the hardware removed previously in this step. At the rear of the pan assembly, insert the hex head bolt to align the pan arm with the tube. **DO NOT LOSE** this hardware. It will be permanently installed when the handle mount mechanism is installed.

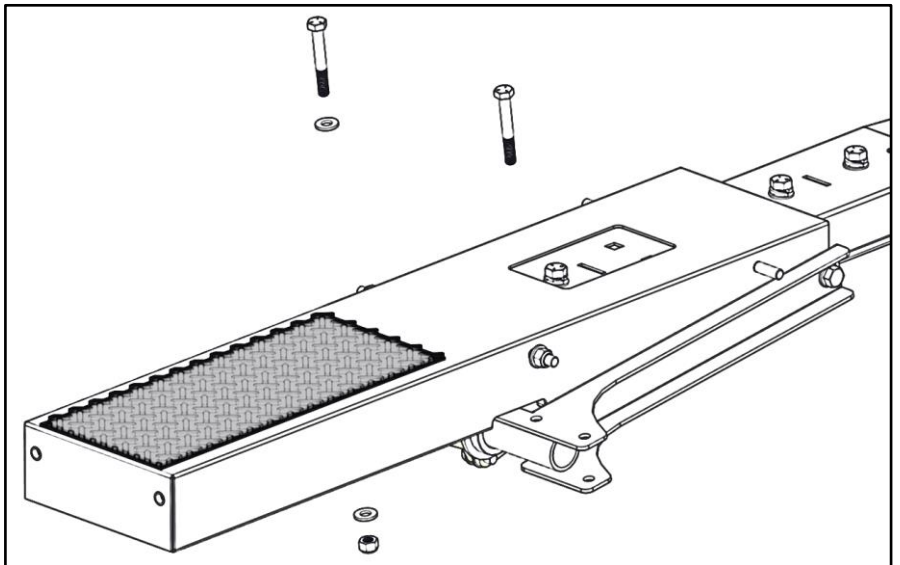

- Snug tighten, but allow movement.



## Step 6 – Install Front Mechanism

- Mount the front mechanism to the underside of the front bow in the location shown.
- Use the hardware pre-installed on the mechanism to attach to the front bow.
- TIGHTEN.

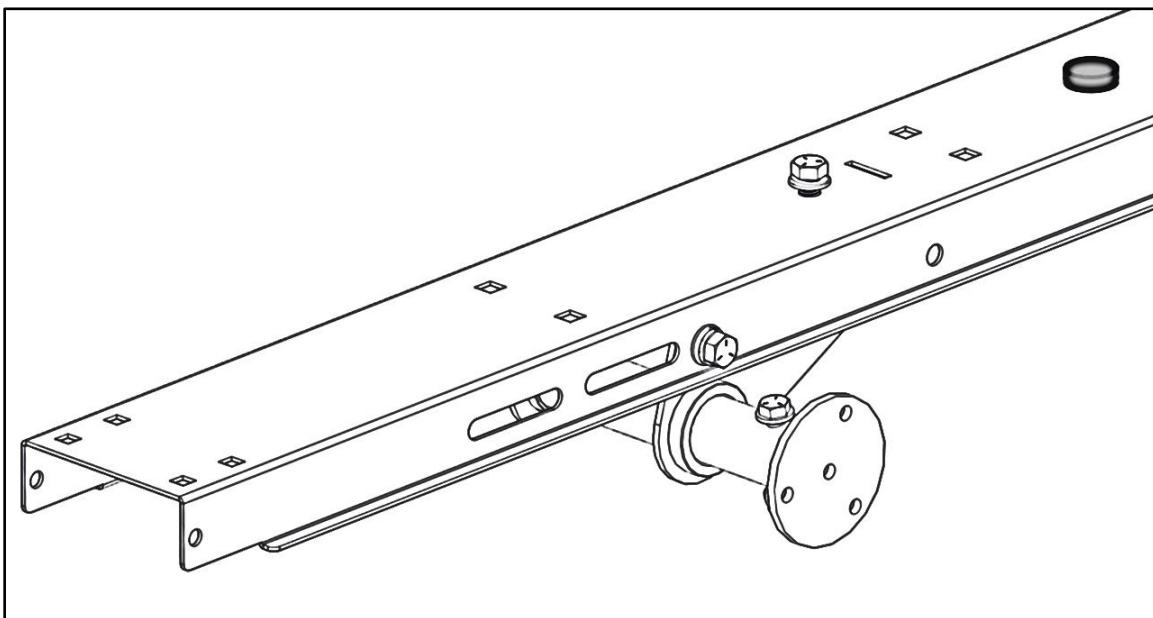
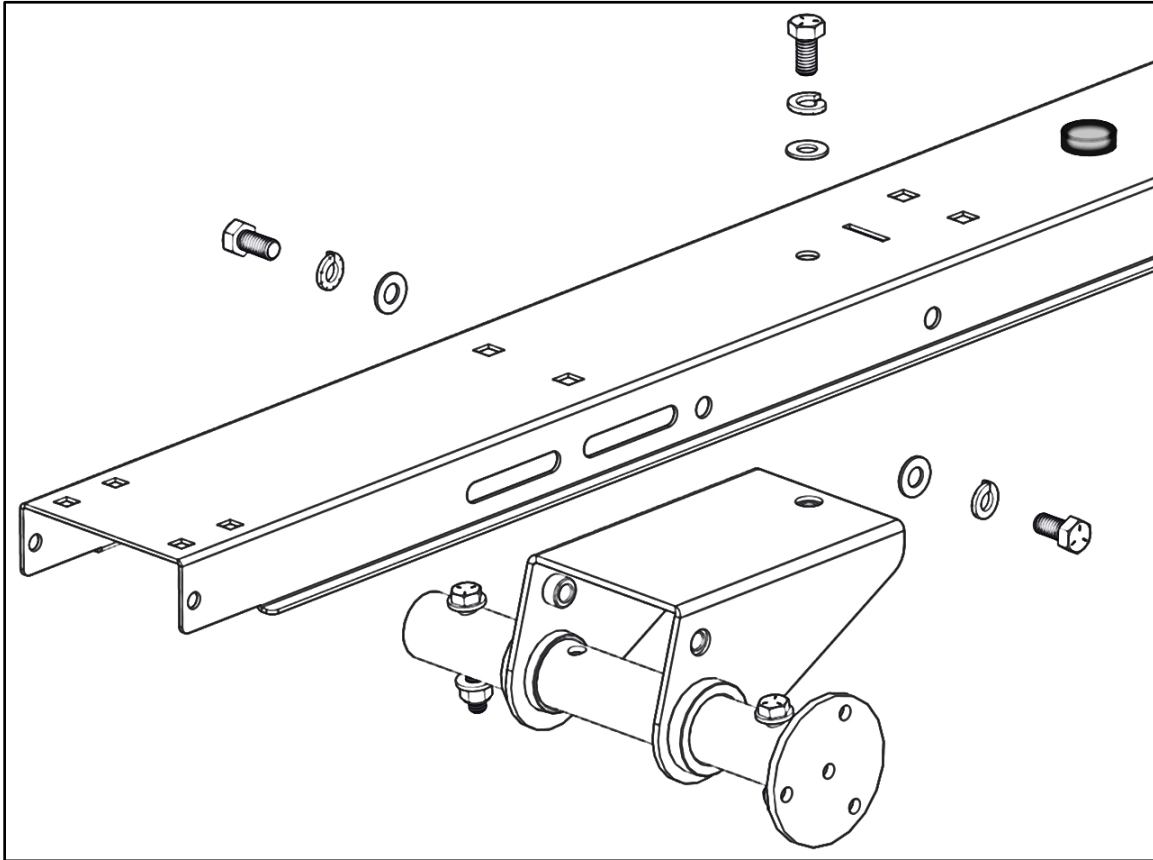

## **Step 7 – Install Front Wheels**

- Slide wheel axle in the holes at the end of the front bow.
- Place a nylon washer on the axle up against the outside of the bow.
- Place a wheel at each end of the axle, one on each side of the bow.
- Cap each wheel with a wheel cap.

**WHILE PLACING THE PAN IN THE NEXT STEP, BE SURE THE WHEEL CAPS DO NOT COME OFF.**

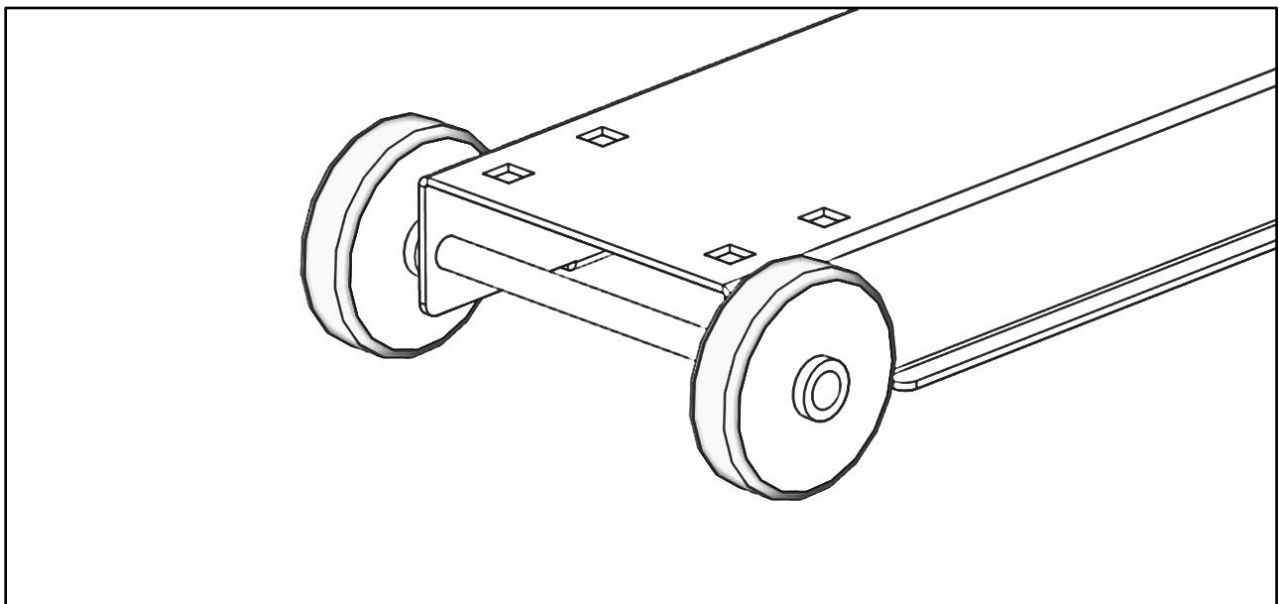
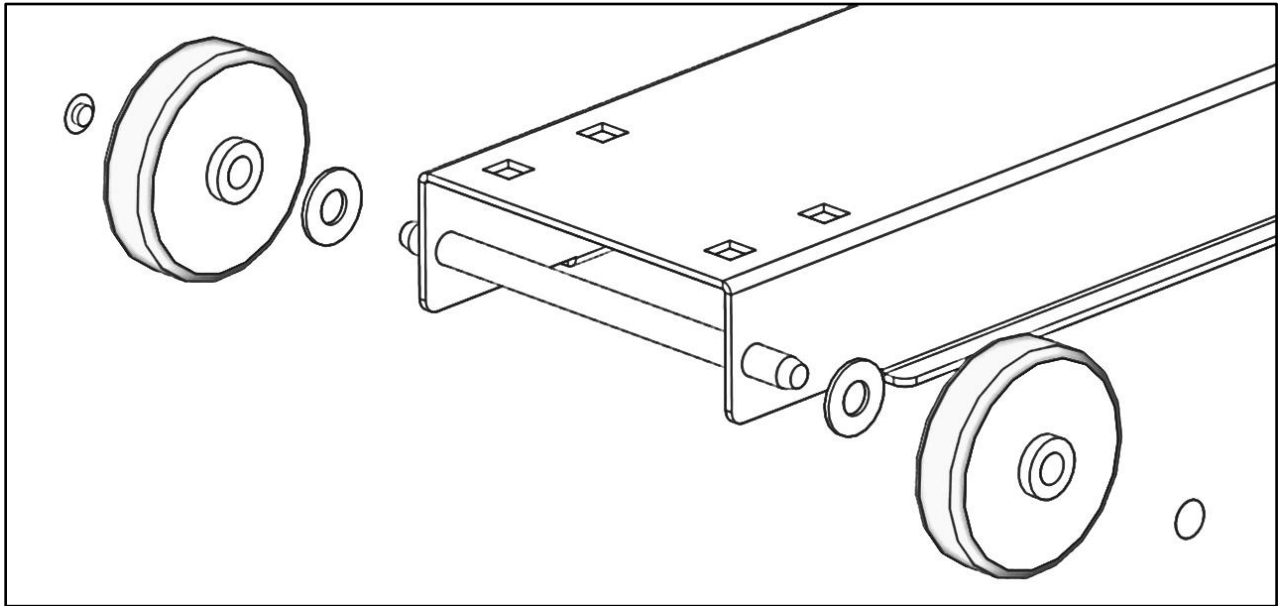

## Step 8 – Install Front Pan

- Remove the hardware shown below from the damper mechanism.

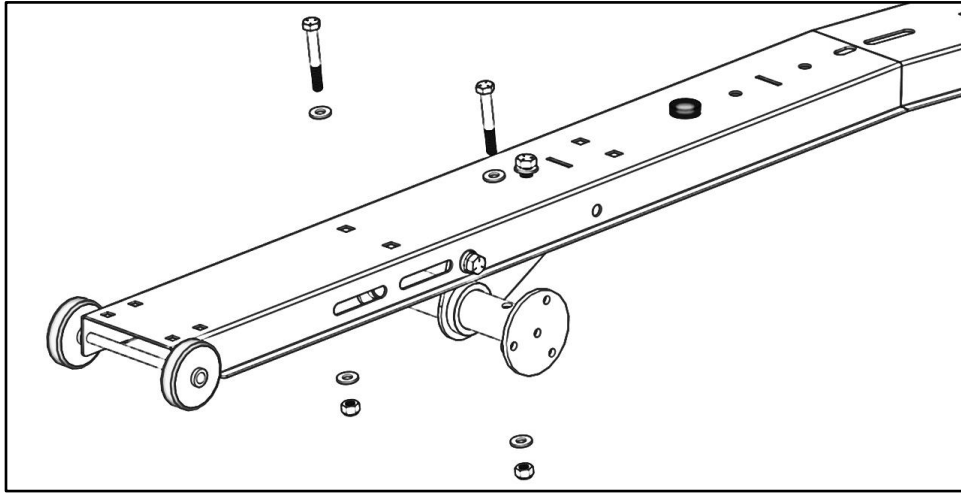

- Place the front pan on top of the wheels and bow. **BE SURE THE WHEEL CAPS DID NOT COME OFF.**
- Align the arms from the front pan with the holes in the tube of the front mechanism where the previous hardware was removed.
- Snug tighten, but allow movement.

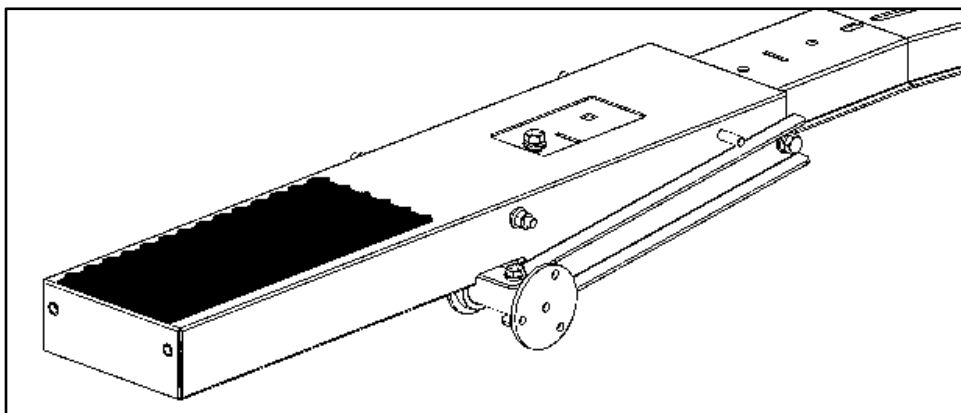
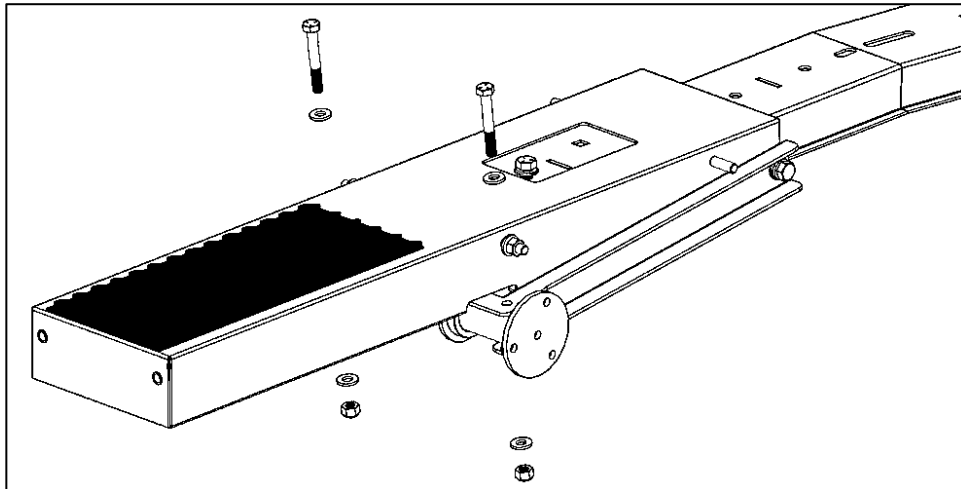

## Step 9 – Install Torque Tube

- Place the torque tube in between the front and rear bow in the location shown.
- Attach the torque tube to the front and rear bow using one 1/4" x 7/8" hex head, two 1/4" flat washers and one 1/4" lock nut for each of the 3 holes. Repeat on each bow.
- Snug tighten, but allow movement.

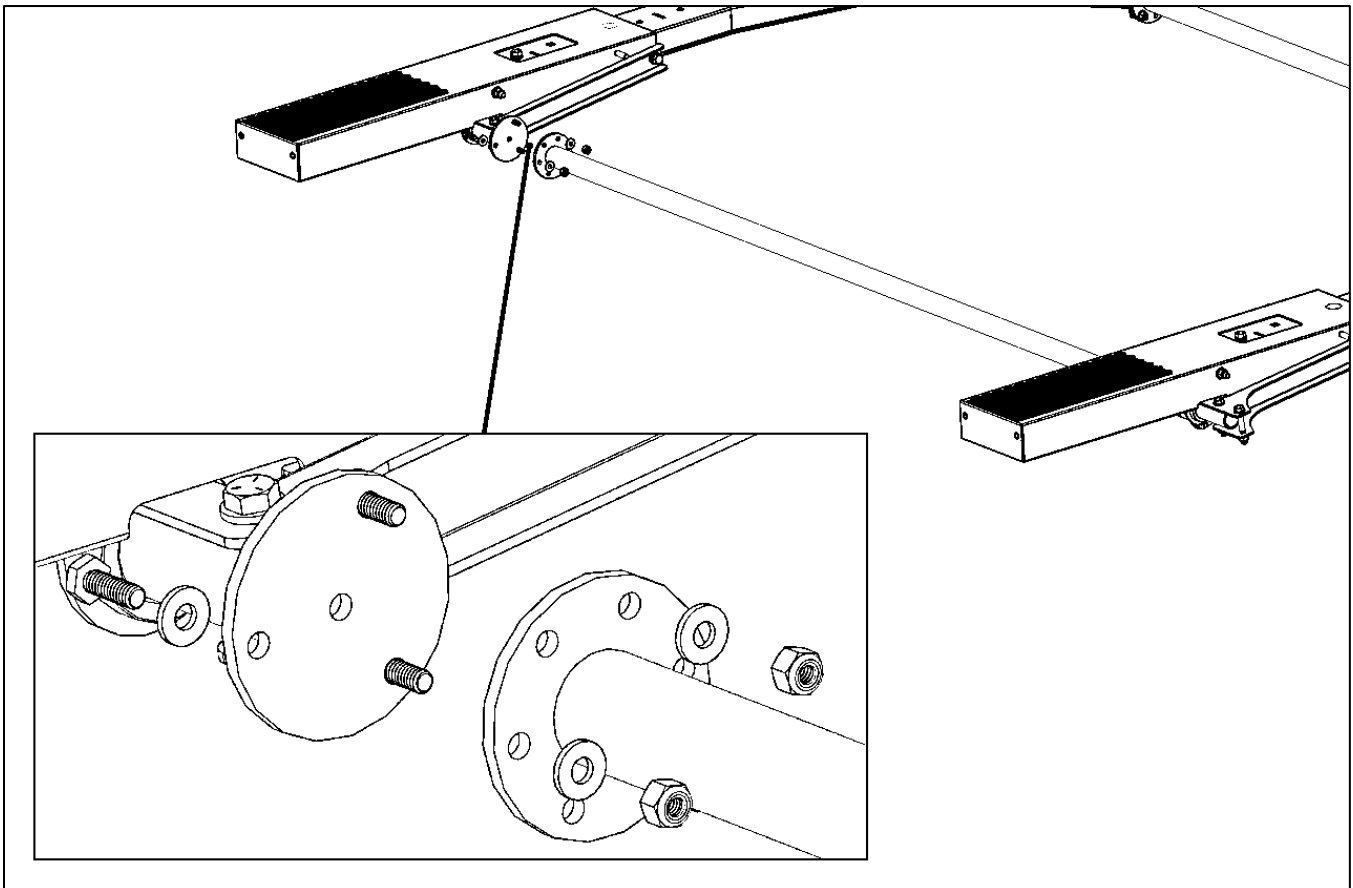
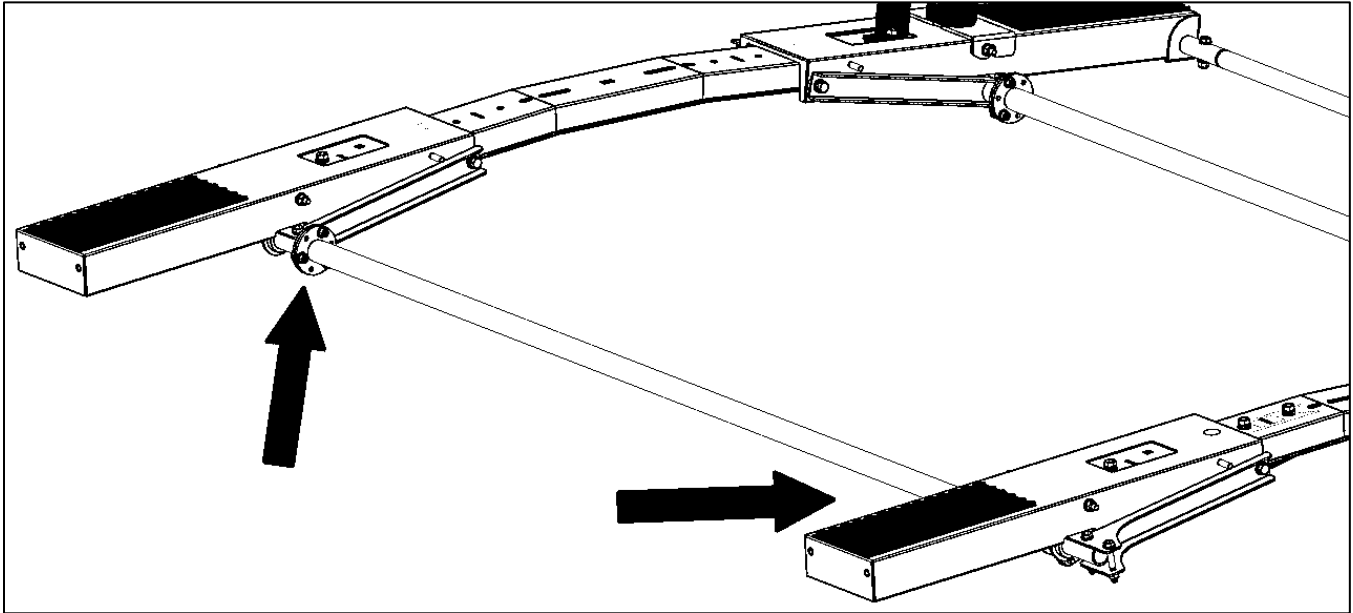

## Step 10 – Install End Tube

- Place the end tube assembly at the end of the front and rear bow.
- Attach the end tube assembly to both bows using 5/16" x 5/8" hex heads, 5/16" lock washers and 5/16" flat washers in that order.
- Snug tighten, but allow movement.

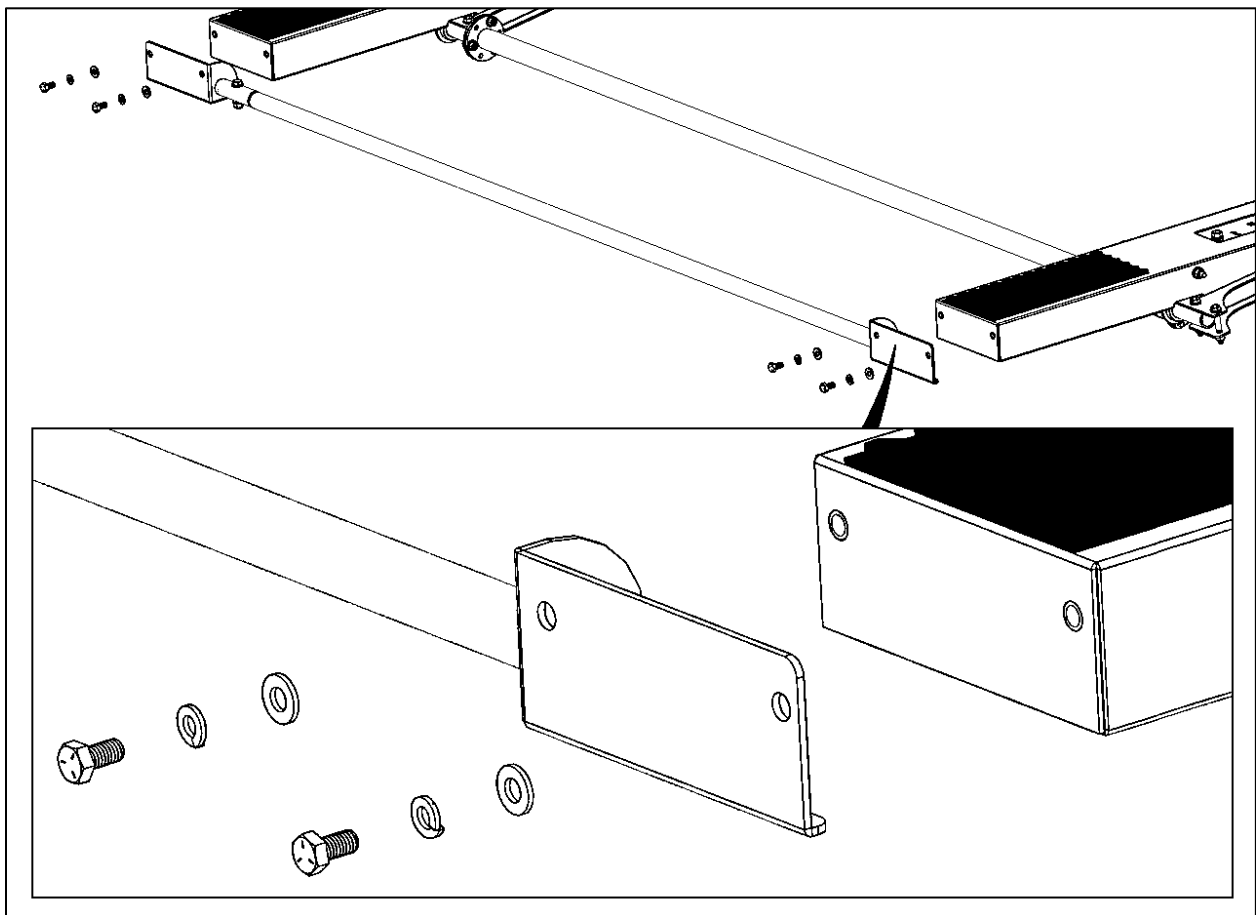
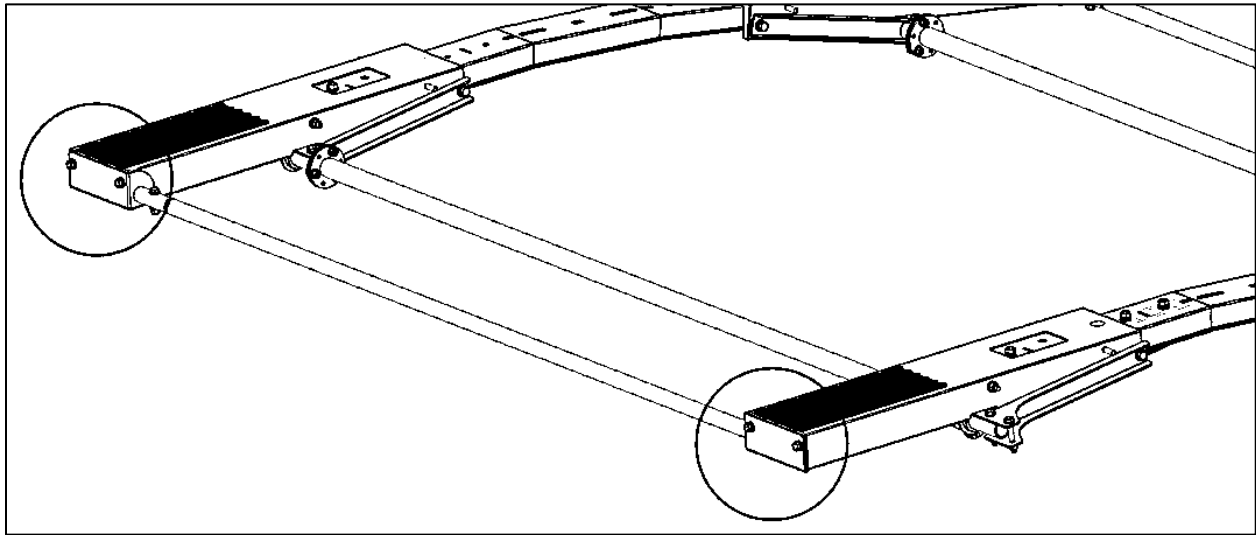

## **Step 11 – Install Ladder Hooks**

- Determine best location for the ladder hooks. There are two options on each bow. These options can be identified by locating the threaded studs sticking outwards from the bow.

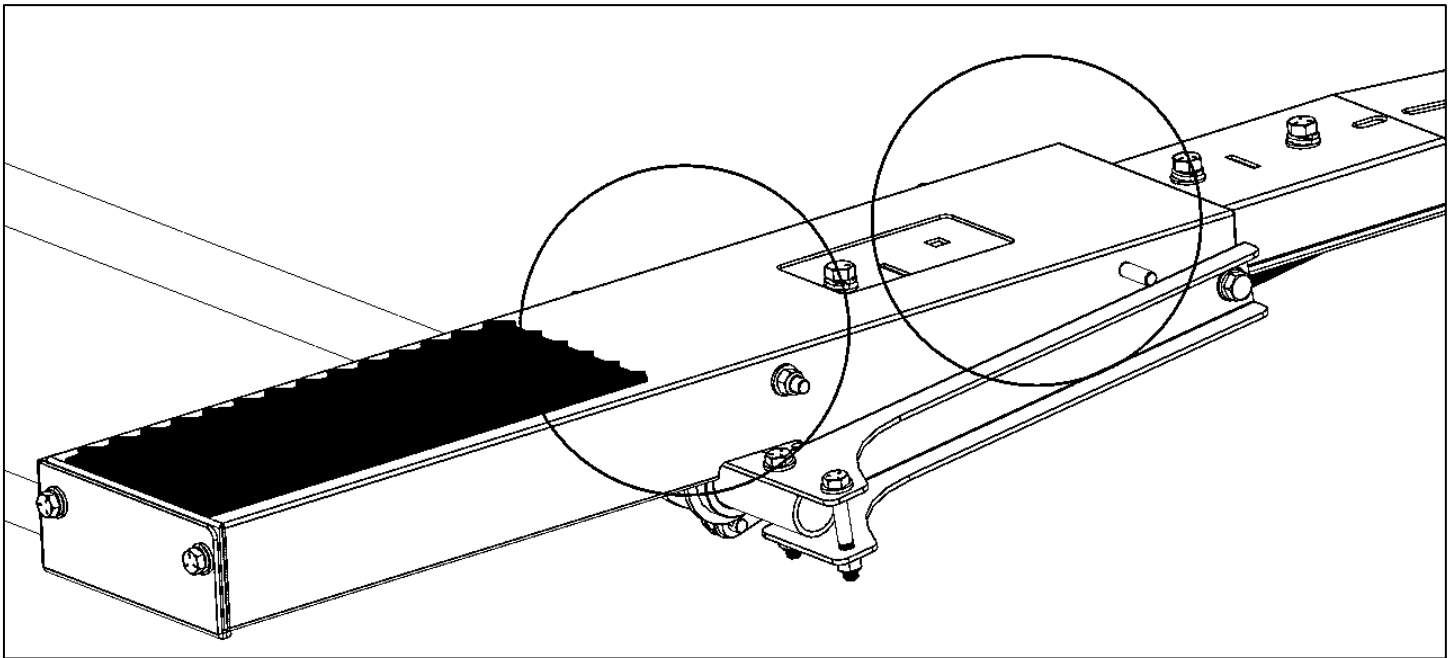

- Typically, the ladder hook on the front bow is installed on the threaded stud closest to the end of the bow.

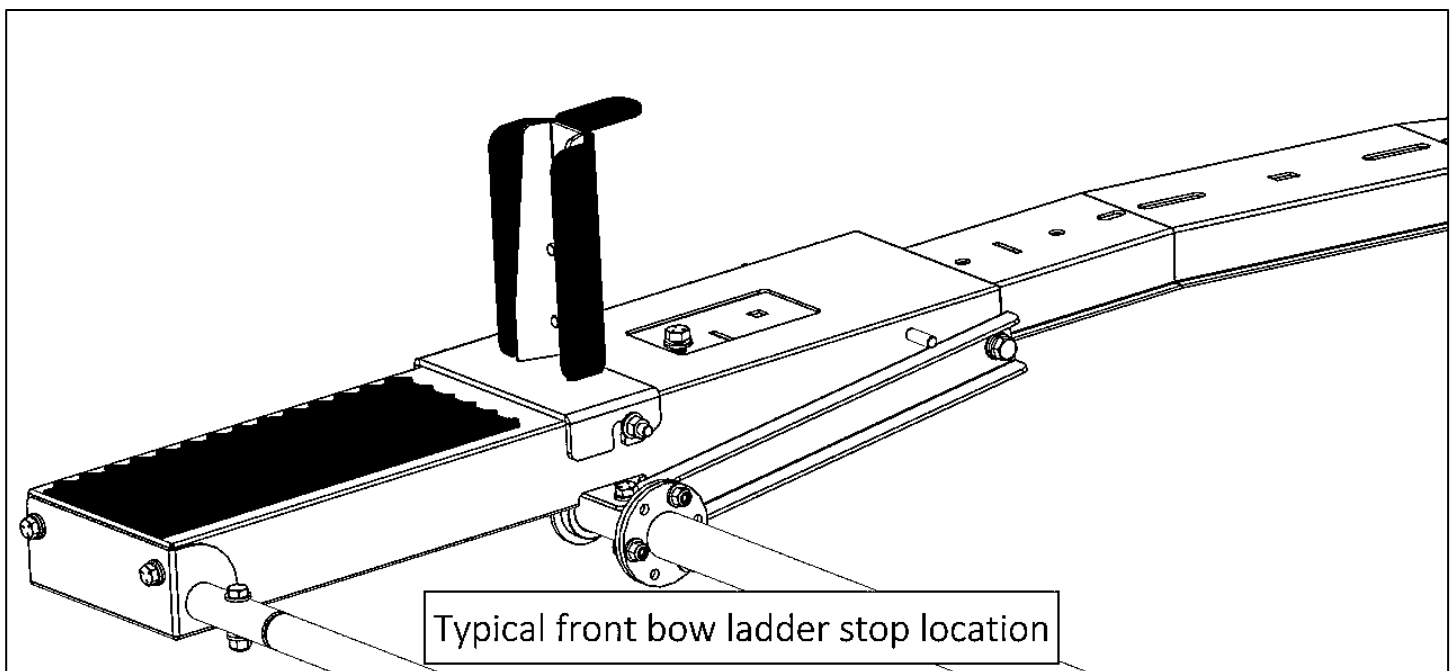

- Typically, the ladder hook on the rear bow changes with the type of ladder being used on the rack.

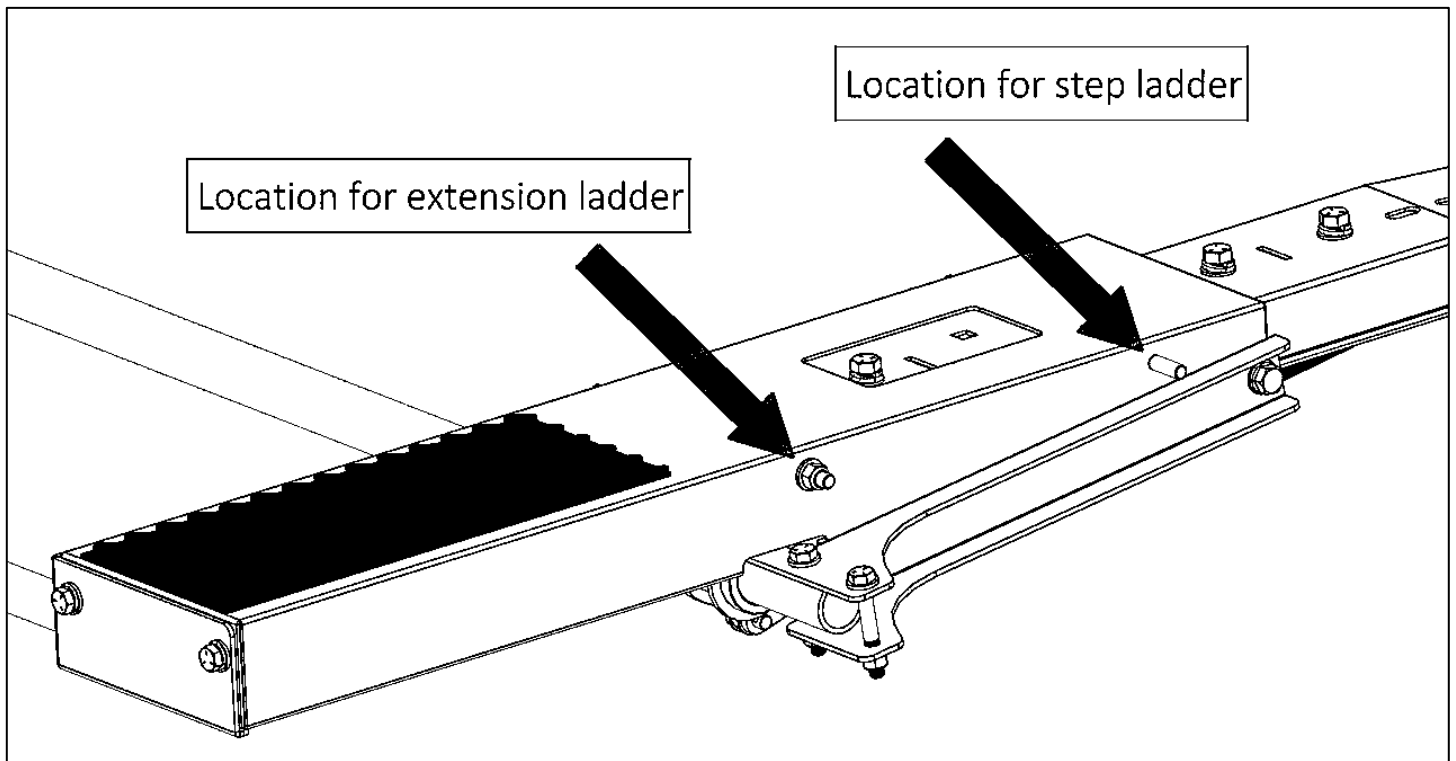

- When using an extension ladder, place the ladder hook at the threaded location closest to the end of the pan.

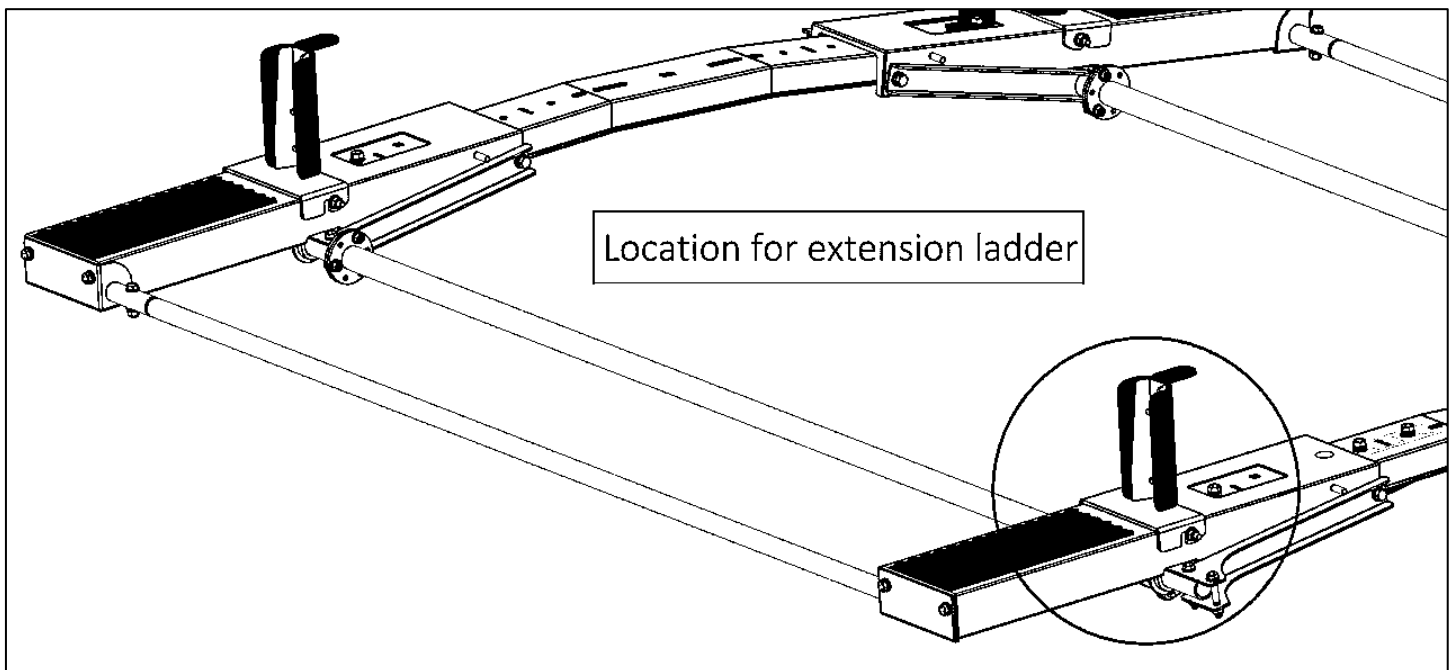

- When using a step ladder, place the ladder hook at the threaded location closest to the center of the bow.

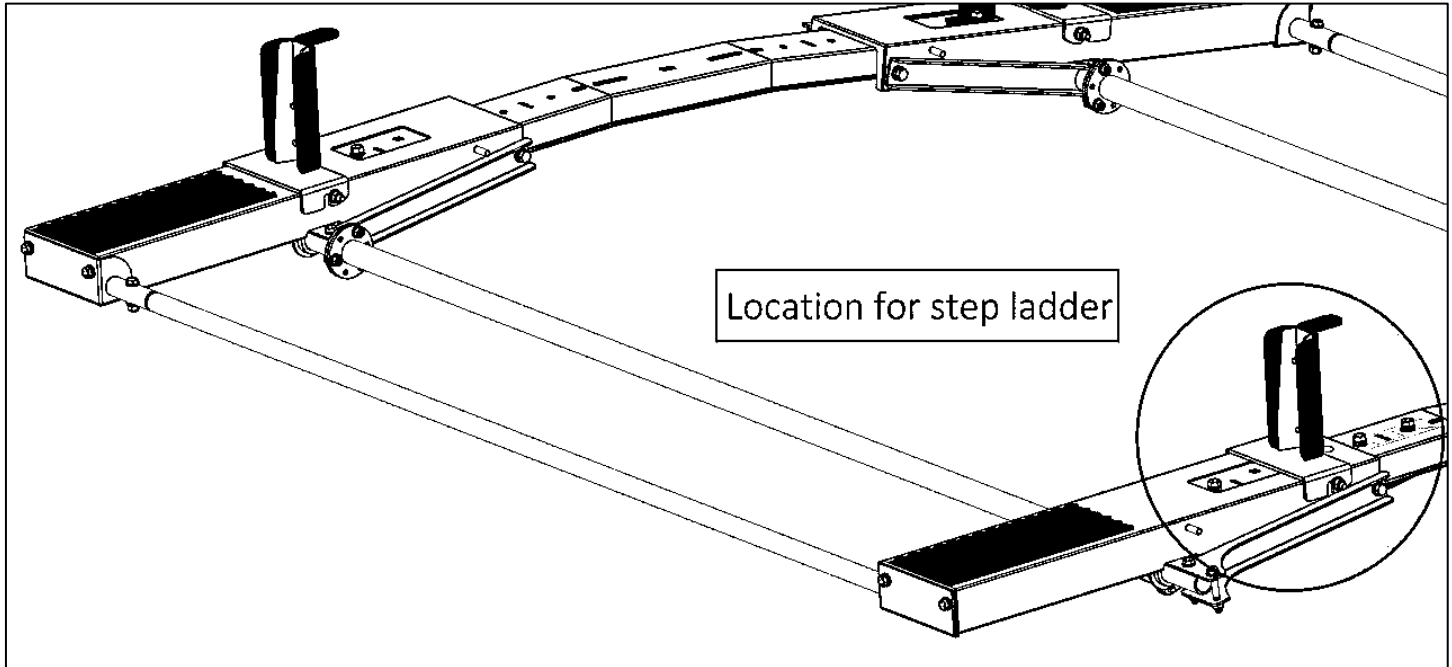

- Using the hardware and the threaded studs on the bows, loosen the nuts and slide ladder hook into place. **Be sure the washers are on the outside of the ladder hook.**
- TIGHTEN.

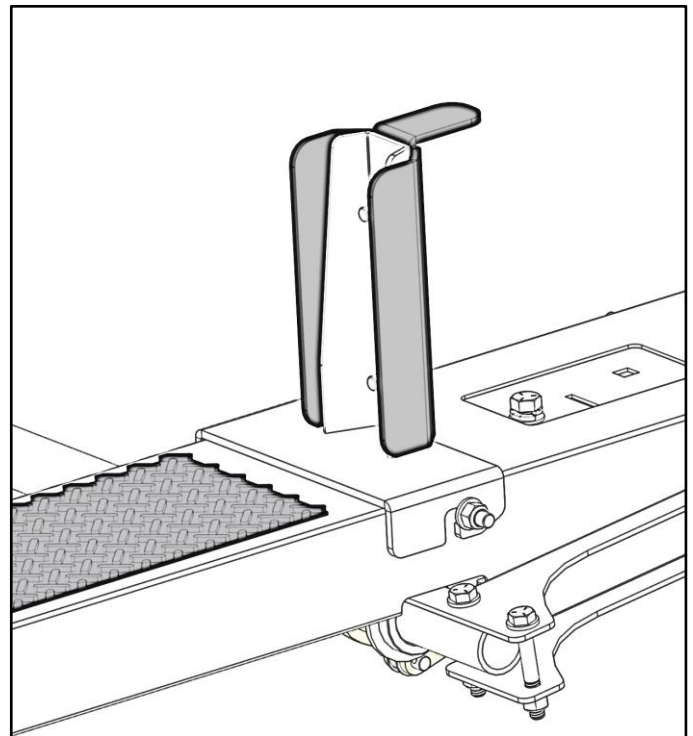
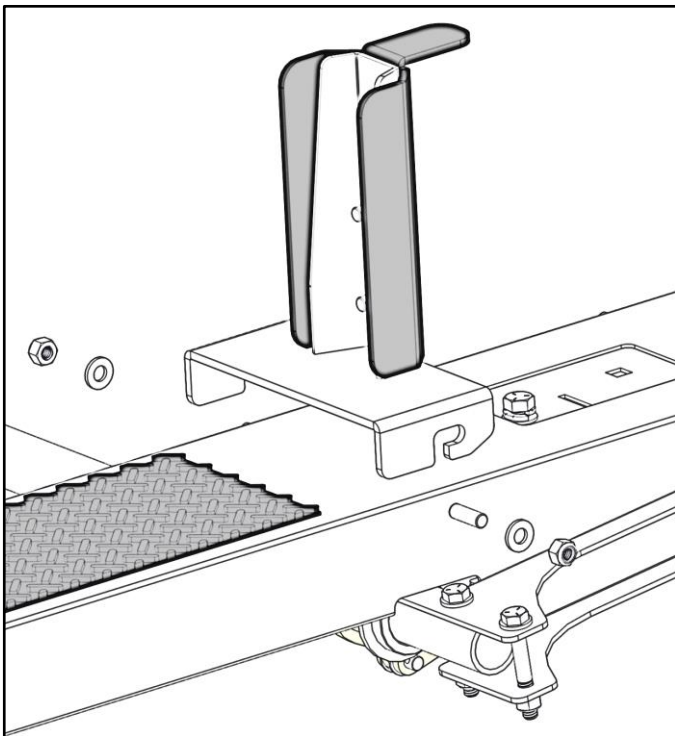



## Step 12 – Install Ladder Stops

- Identify the potential ladder stop location near the previously installed ladder hooks.
- Remove the installed hardware on the bows next to the rectangular cut outs near the installed ladder hooks.
- The ladder stop and the ladder hook will provide a secure location for a ladder to be placed.
- **Be sure the flange on the ladder stop aligns inside the rectangular cut out in the bow.**
- **Attach the ladder stop using the hardware previously removed.**
- TIGHTEN.

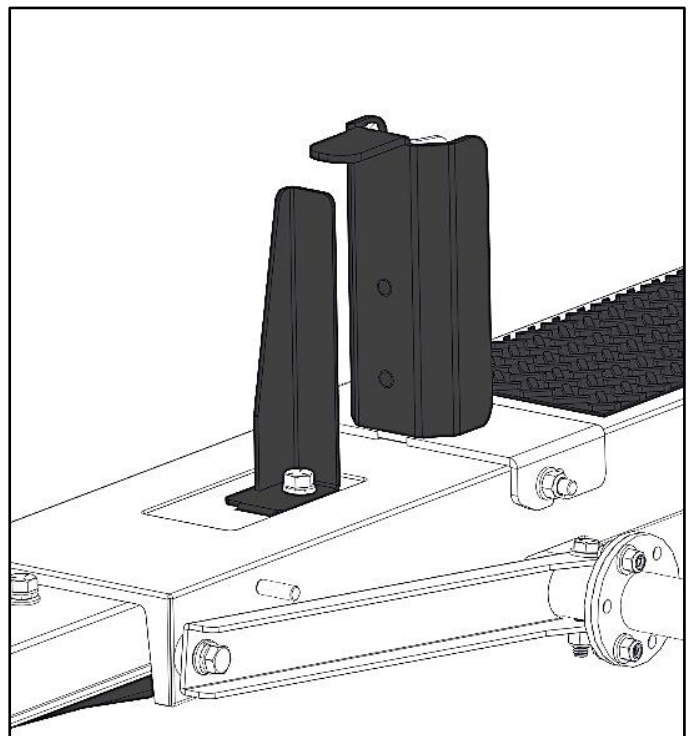
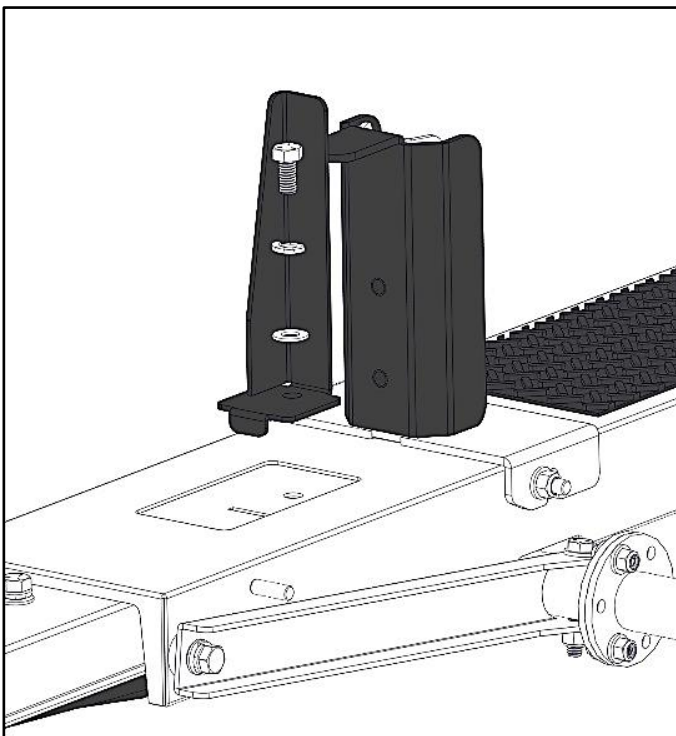
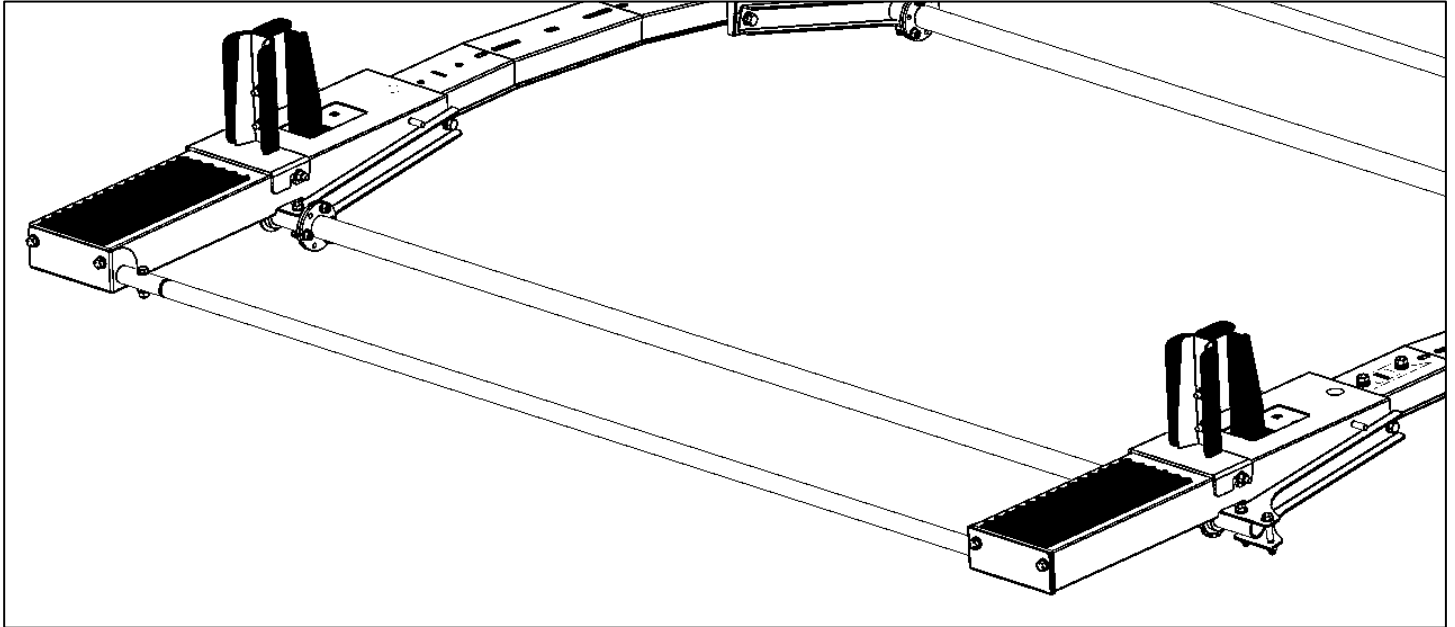

## **Step 13 – Install Handle Mechanism**

- Place sealant along the swage joint to ensure no water can enter the tube.
- Insert the handle mechanism into the swage on the rear bow.
- Use the hardware removed in Step 5 to attach the mechanism.
- TIGHTEN.

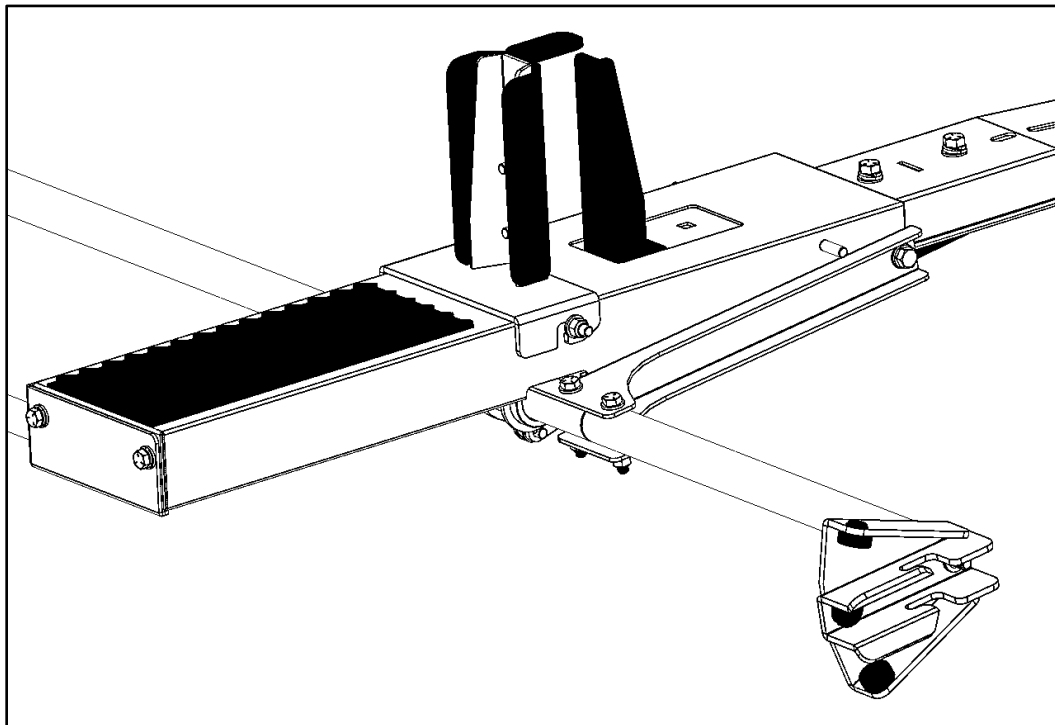
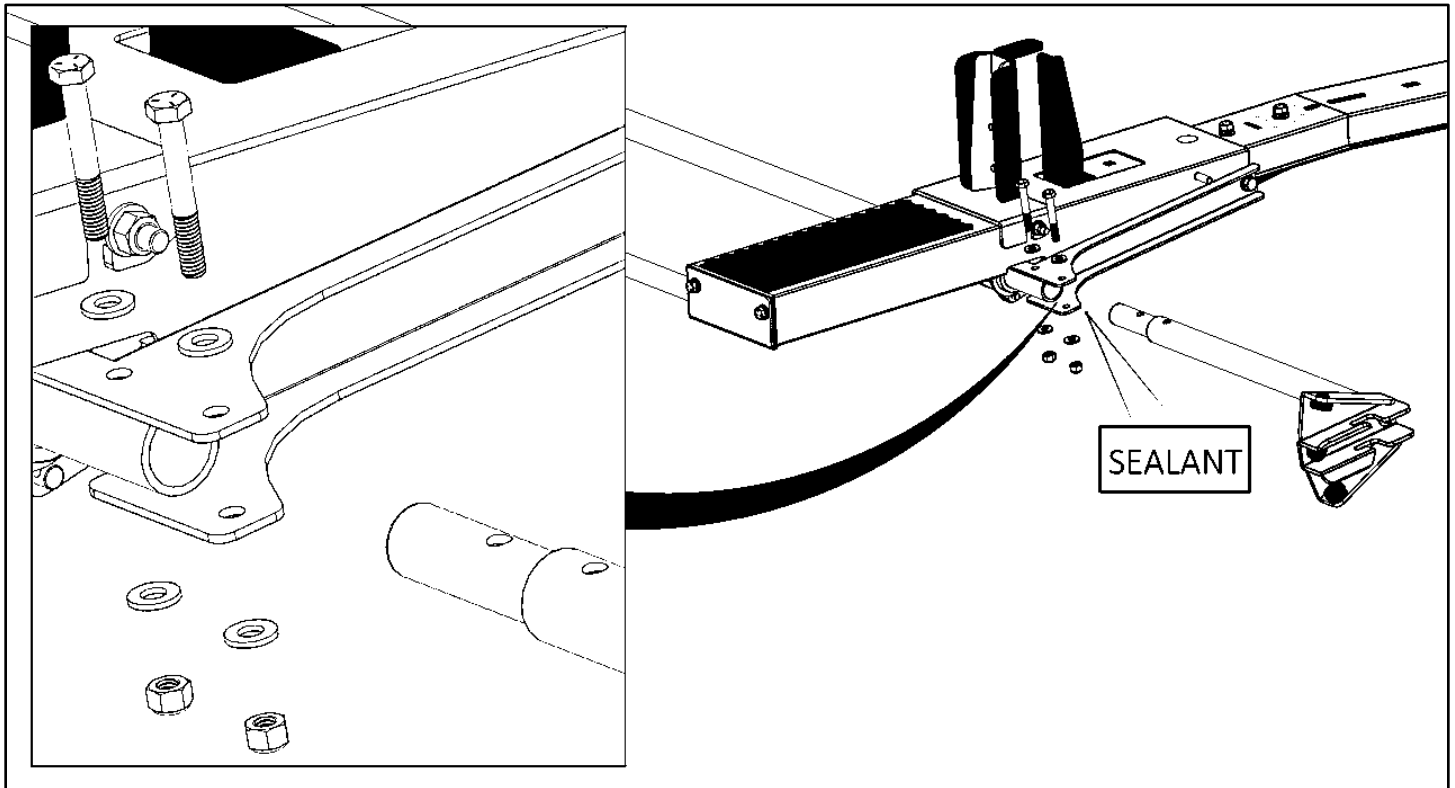

## Step 14 – Use Handle

- Go back and tighten all hardware on rack. Start at the rear and in the middle of the rack and work your way forward.
- Use the handle that is included with the main rack assembly to operate the rack. **Be sure there are no issues with operation.**
- If the dampers were not able to be installed in previous steps, go back and install the dampers as needed by using the handle as leverage.

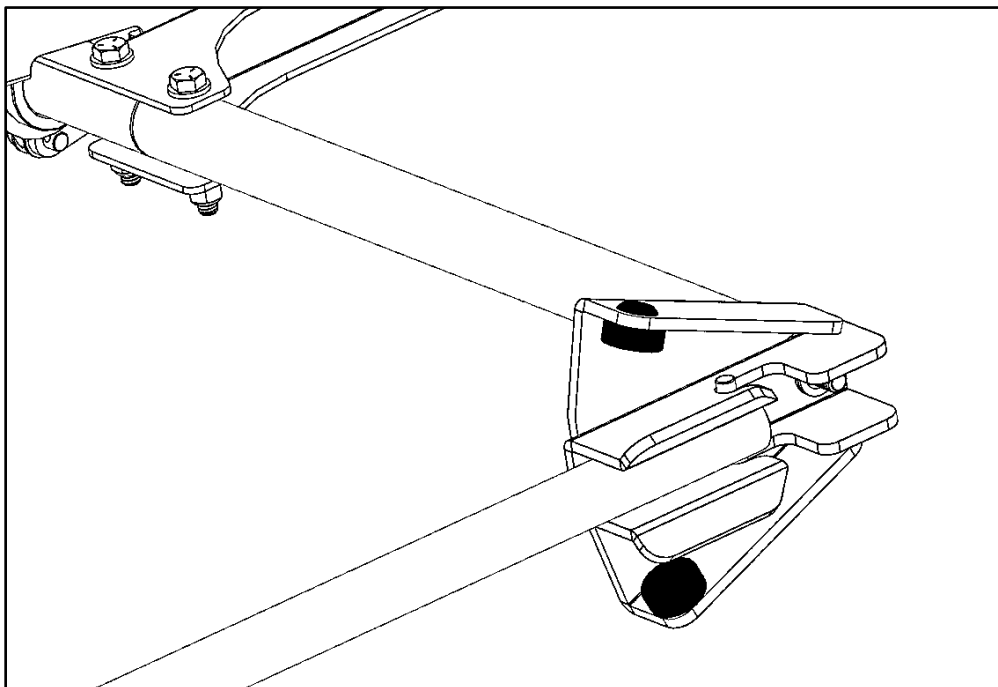
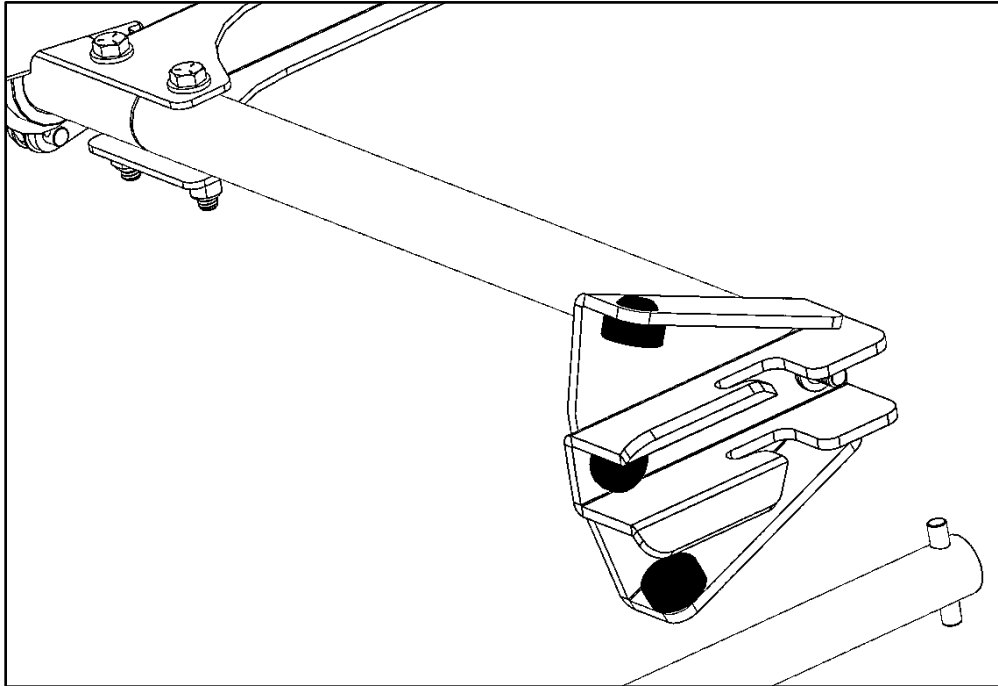

**ENSURE ALL HARDWARE IS TIGHT.**

**DO NOT EXCEED MANUFACTURERS WEIGHT CAPACITY.**

**YOUR INSTALLATION IS NOW COMPLETE.**

