

Holman

Instruction Guide 48301PC

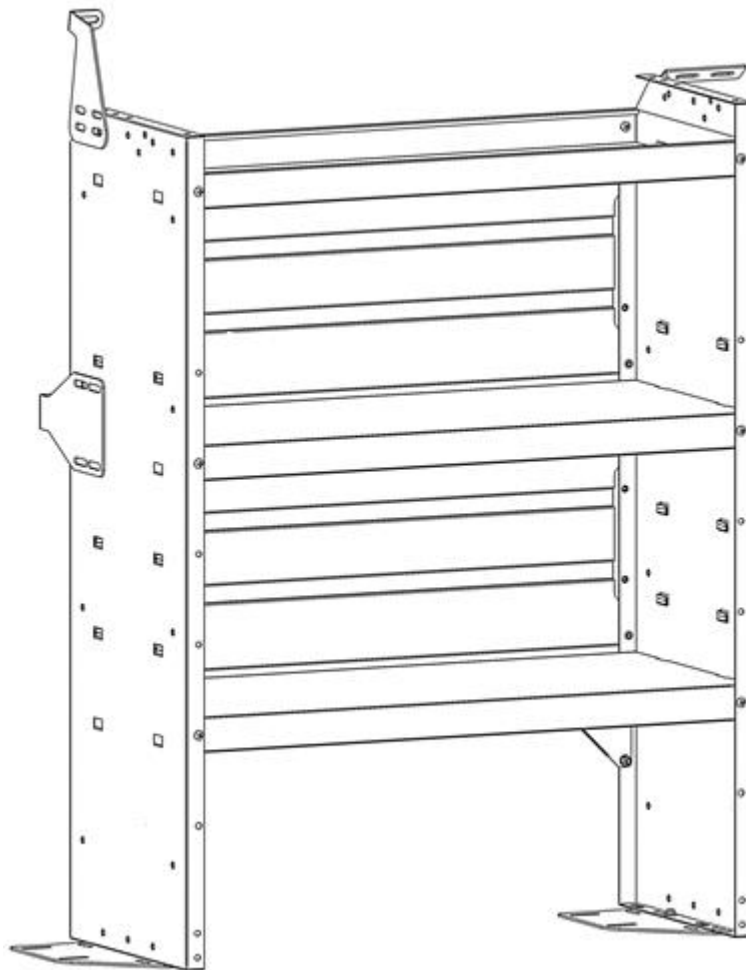

Holman
Rancho Cordova, CA 95742
800-343-7486
InstallationSupport@Holman.com

PLEASE READ ALL INSTRUCTIONS AND WARNINGS PRIOR TO ASSEMBLING, INSTALLING, AND USING THIS PRODUCT.

Warning



Always check for wires, fuel tanks and lines, brake lines and other important vehicle functionality items prior to drilling and installing all products.

Tools Needed

7/16", 1/2", 9/16" Sockets and Wrench	10mm Socket and Wrench
7/16" Box Wrench	Drill
25/64" Drill Bit	Drill Stop

Table of Contents

Before You Begin 1

Parts List 2

Hardware 2

Shelf Assembly Options 4

Step 1 – Determine Installation Location 4

Step 2A – Installing Shelf Directly to Threaded Bosses 5

Step 2B – Install Shelf Offset of Threaded Bosses 5

Step 3 – Install L-Mounting Bracket 6

Step 4 – Install 2014TC Wall Mount 7

Step 5 – Install Door Mount Bracket 8

Before You Begin

- Read all instructions prior to installing any Holman product.
- Ensure it is safe to drill before drilling anywhere on vehicle.
- Instructions shown using a 43”H x 32”W shelf. Instructions are the same for the 26”W shelf.
- **When installing, LIFT shelf into position, DO NOT DRAG shelf to position.**



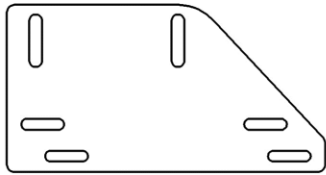
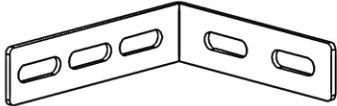
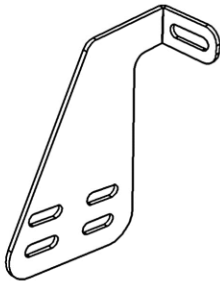
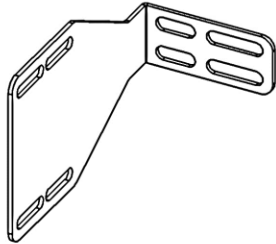

Parts List

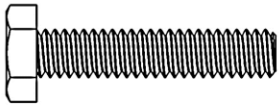
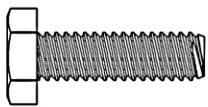
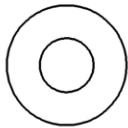
ITEM NO.	ITEM	PART NUMBER	DESCRIPTION	QTY.
1		4016L-43-001	BASE PLATE BRACKET	2
2		4016T-10-005	L MOUNTING BRACKET	1
3		4016L-43-004	2014TC DOOR MNT BRKT	1
4		4016L-43-003	2014TC WALL MOUNT-02	1
5		18-48301PC	48301PC HARDWARE KIT	1

Hardware

ITEM	HARDWARE TO SCALE	PART NUMBER	DESCRIPTION	QTY.
1		13800	1/4"-20 X 1-1/4" HEX HEAD BOLT	1
2		13004	1/4"-20 X 7/8" HEX HEAD BOLT	4
3		33078	1/4" FLAT WASHER	11

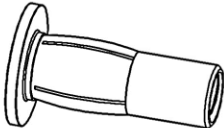
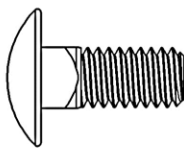
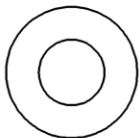
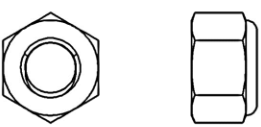
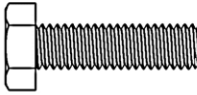
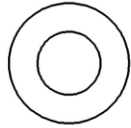
Hardware (Continued)

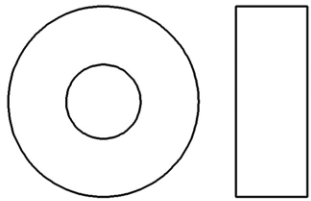
ITEM	HARDWARE TO SCALE	PART NUMBER	DESCRIPTION	QTY.
4		33618	1/4" LOCK WASHER	3
5		37018	1/4"-20 NYLON INSERT LOCK NUT	4
6		920313726	1/4"-20 PLUS NUT	1
7		21810	5/16"-18 X 3/4" CARRIAGE BOLT	4
8		33080	5/16" WASHER	4
9		0169777	5/16"-18 NYLOC	4
10		38566	M6-1 X 25MM HEX HEAD BOLT	2
11		40357	M8 FLAT WASHER	1
12		11511017	M8-1.25 NYLON NUT	1
13		11517442	3/8" ID 1" OD NYLON SPACER	2

Shelf Assembly Options

- Option 1: Bottom shelf moved up one location and lower back panel removed. This assembly configuration allows the shelf to be moved closer to the wall giving more aisle room.
- Option 2: Bottom shelf on bottom location, lower back panel in place. In this assembly configuration, allows Holman drawer units to be mounted to the bottom shelf.

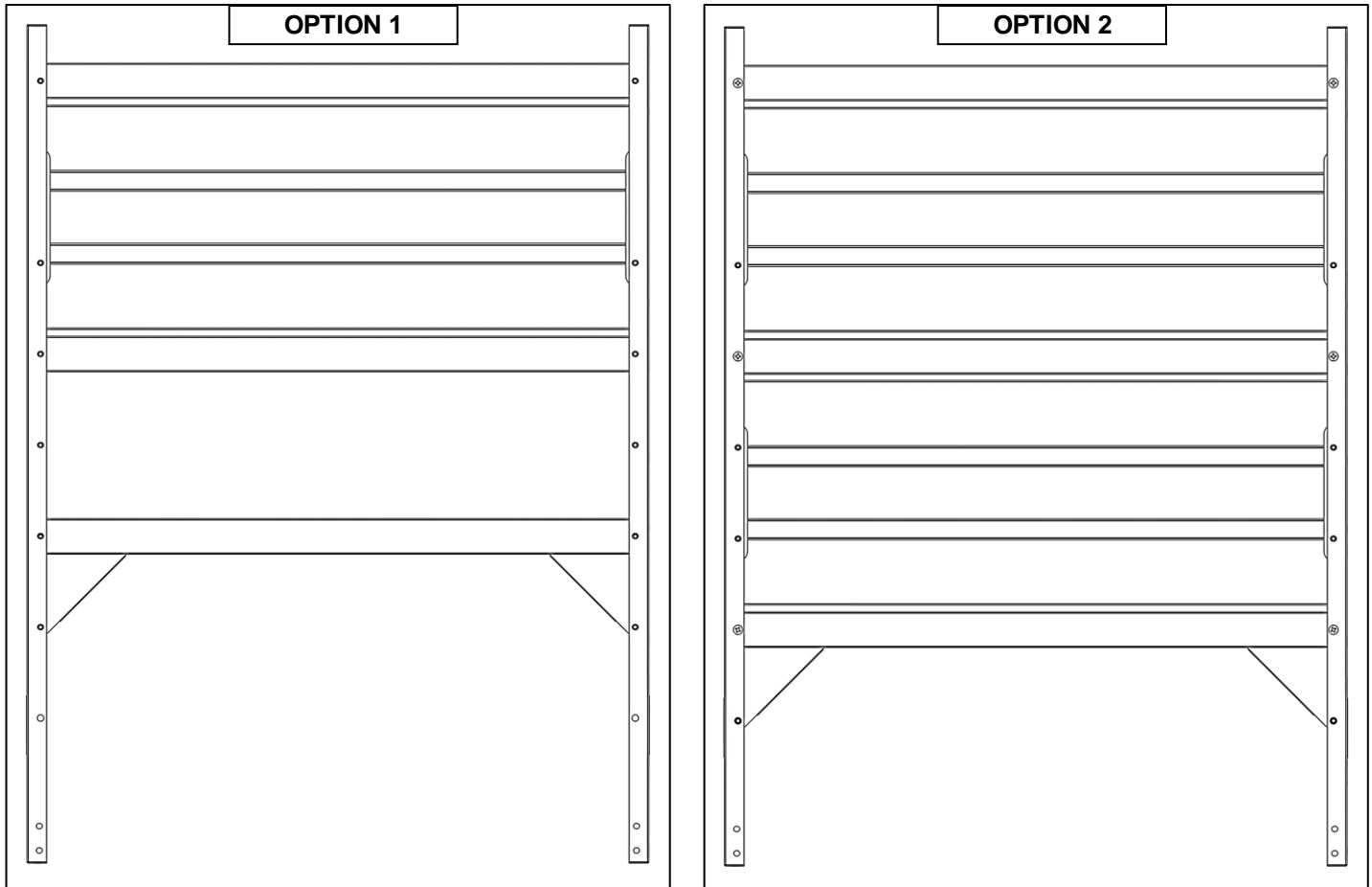

Step 1 – Determine Installation Location

- Remove D-rings installed on the floor to the front of and rear of the wheel well.
- **Determine the desired installation position. The shelf may be installed in different positions as follows.**
 - **The shelf may be installed directly onto D-ring threaded bosses. Proceed to Step 2A.**
 - **The Base Plate Brackets may be installed and the shelf installed into the van offset forward or backward to the D-ring threaded holes. Proceed to Step 2B.**

Step 2A – Installing Shelf Directly to Threaded Bosses

- Set shelf in vehicle with holes in bottom of shelf aligned with threaded bosses.
- Using two M6 x 25MM bolts, two 1/4" flat washers, two 1/4" lock washers, and if necessary, two 3/8" nylon floor spacers, bolt the shelf to the threaded bosses in the floor. Be sure to insert the 3/8" nylon floor spacers between shelf and floor if gap exists between shelf and floor.
- Skip Step 2B.

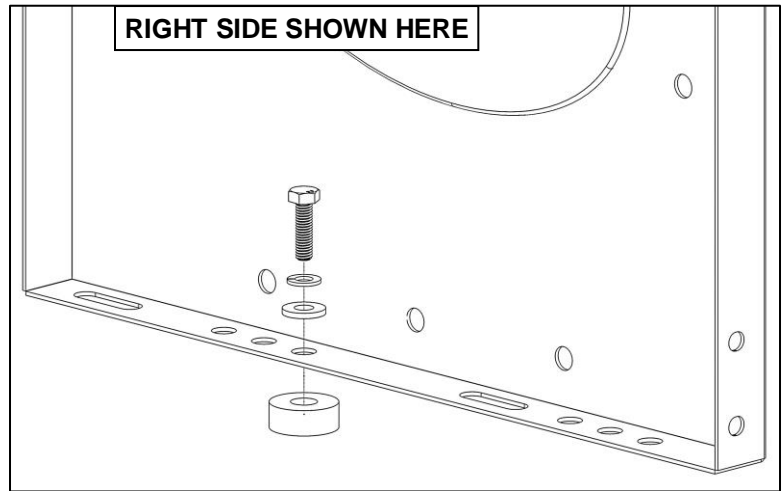

Step 2B – Install Shelf Offset of Threaded Bosses

- Using two 5/16" x 3/4" carriage bolts, two 5/16" flat washers, and two 5/16" lock nuts, install the base plate brackets to the bottom of the shelf per the following diagrams.
- Repeat on opposite side.

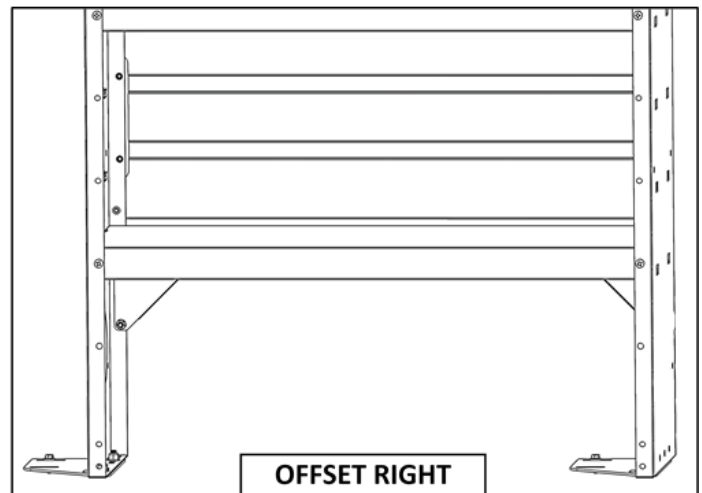
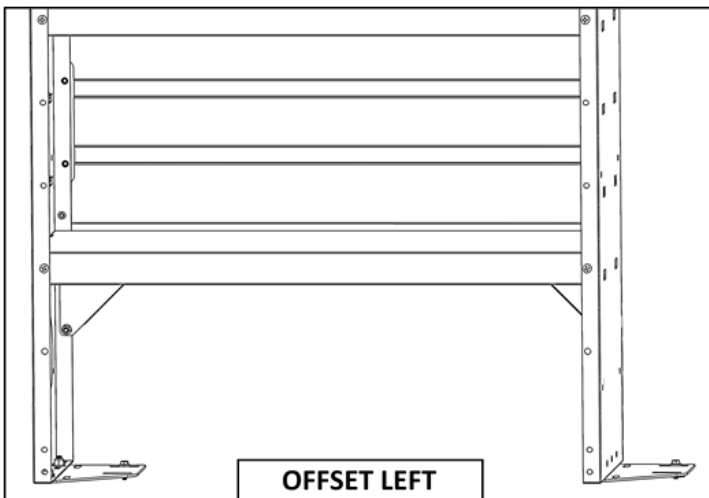
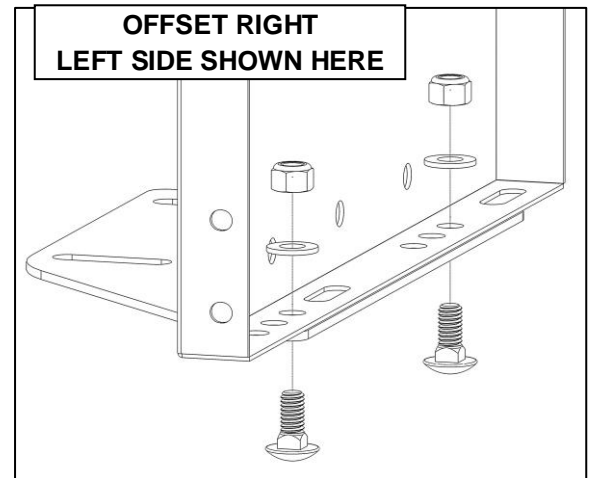

- Using one M6 x 25MM bolts, one 1/4" flat washer, one 1/4" lock washer, and if necessary, one 3/8" nylon floor spacer, bolt the shelf to the threaded bosses in the floor. Be sure to bolt the 3/8" nylon spacer between shelf and floor only if gap exists between shelf and floor.
- Repeat on opposite side.

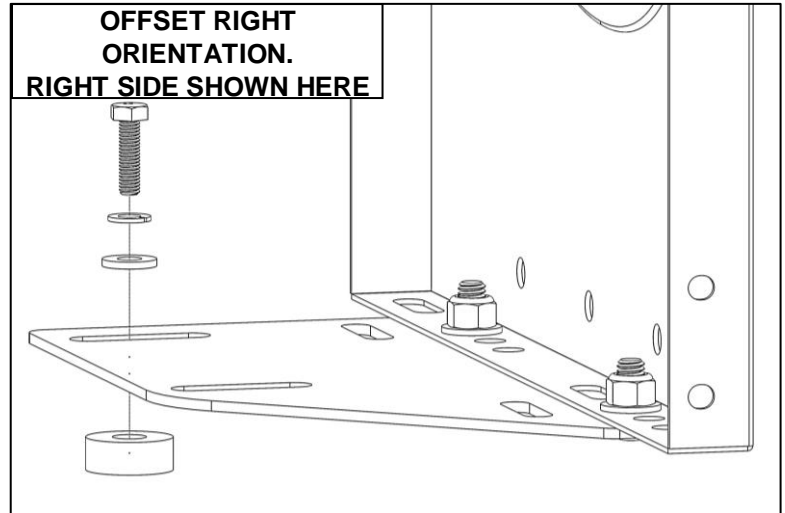

Step 3 – Install L-Mounting Bracket

- Place and hold the L-mounting bracket in a position at the rear of the shelf so one of the slots in the L-mounting bracket aligns with a hole in the shelf. It is recommended to attach the rear of the shelf to the rear pillar of the vehicle.
- Using one 1/4" x 7/8" bolt, two 1/4" flat washers, and one 1/4" lock nut, loosely bolt the L-mounting bracket to the shelf unit.
- Using one 1/4" x 7/8" bolt, two 1/4" flat washers, and one 1/4" lock nut, bolt the L-mounting bracket to the rear pillar unit. There are existing holes in the rear pillar of the van that can be utilized. The picture shows a 46" high shelf installation. If installing a 43" high shelf, use the lower slot on the L-mounting bracket.

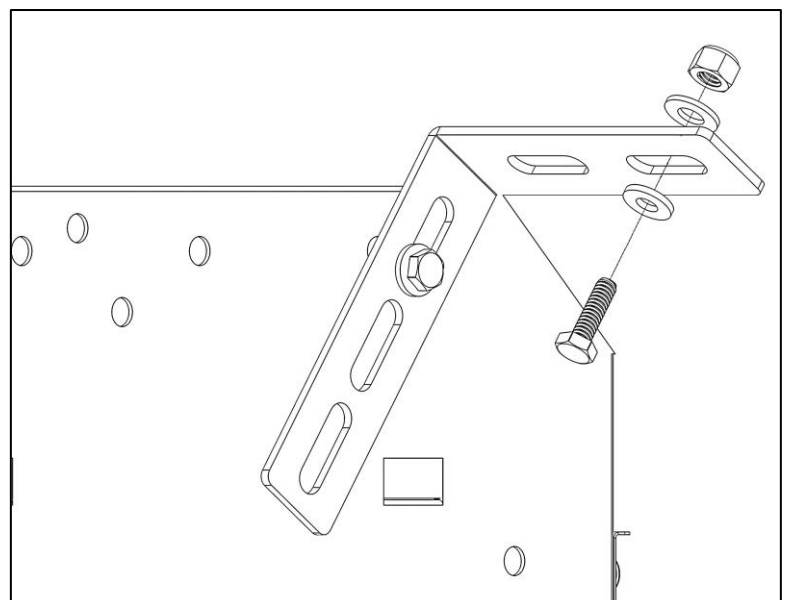
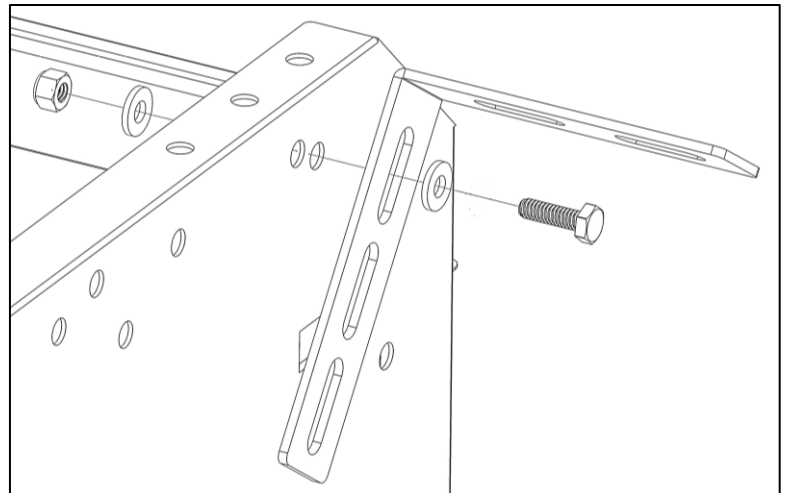

Step 4 – Install 2014TC Wall Mount

- Using one M8 washer and M8 lock nut, LOOSELY install the wall mount onto the van's factory installed stud protruding from the wall.

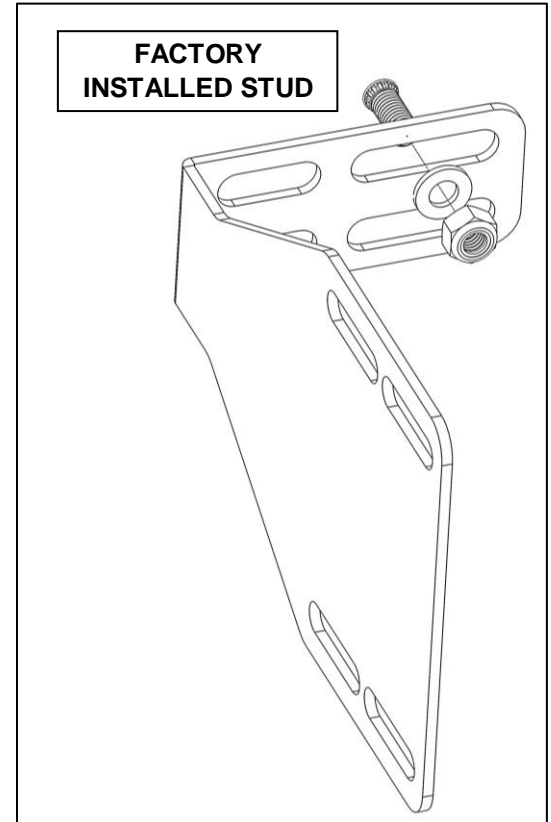

- Set the wall mount against the left side of the shelf and align a hole in the wall mount to a hole in the shelf.
- Using one 1/4" x 7/8" bolt, two 1/4" flat washers, and one 1/4" lock nut, LOOSELY bolt the wall mount to the side of shelf.

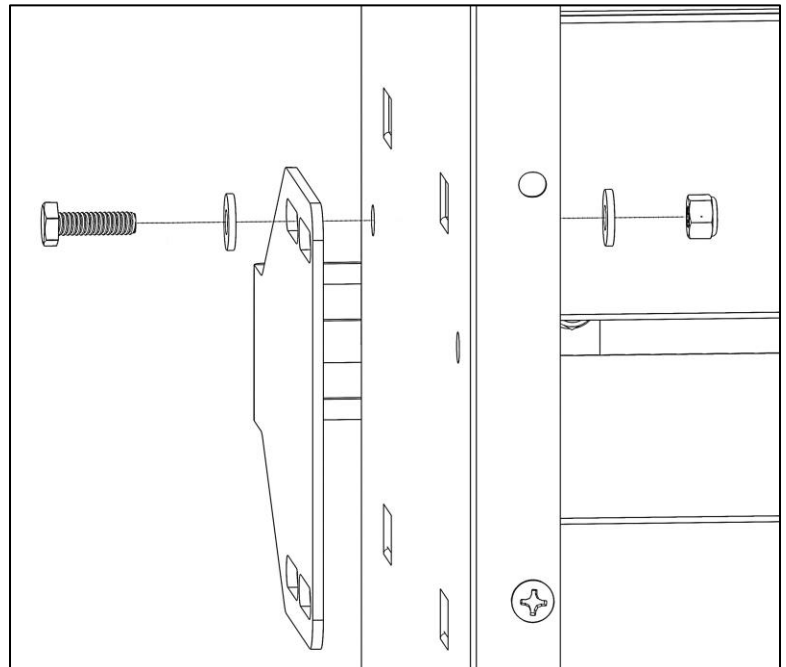

Step 5 – Install Door Mount Bracket

NOTE: The door mount bracket requires drilling and installation of a plus nut. It is not required for all installations but is highly recommended for added support.

- Place the door mount bracket against the van side panel and align one of the holes in the door mount bracket to a hole in the shelf.
- Using one 1/4" x 7/8" bolt, two 1/4" flat washers, and one 1/4" lock nut, bolt the door mount bracket to the side of shelf **SNUGLY, BUT ALLOW FOR MOVEMENT.**
- Mark the location of the slot onto the van side panel.
- Rotate the wall mount out of the way.

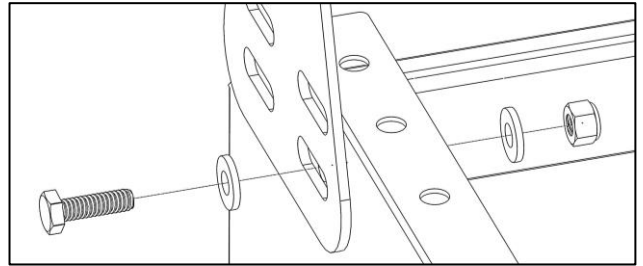

When installing hardware through any installation surface, always ensure the area behind the installation surface is clear of electrical wiring, fuel tank or lines, or any vehicle safety features.



Use a drill stop to keep from drilling through van side.

- At the location marked, drill a hole using a 25/64" drill bit and appropriate sized drill stop. A 3/8" drill bit can be used, although it may be necessary to tap in the plus nuts with a rubber mallet.
- Screw 1/4" x 2-1/4" hex head bolt through plus nut installation tool P9902, and then into plus nut. Knurled end of plus nut tool must be directed away from bolt head and contacting plus nut.
- Insert plus nut into hole.
- Using the 9/16" box wrench, hold the plus nut tool stationary and then tighten hex head bolt until plus nut is tightly gripping and does not spin when hex bolt is loosened.

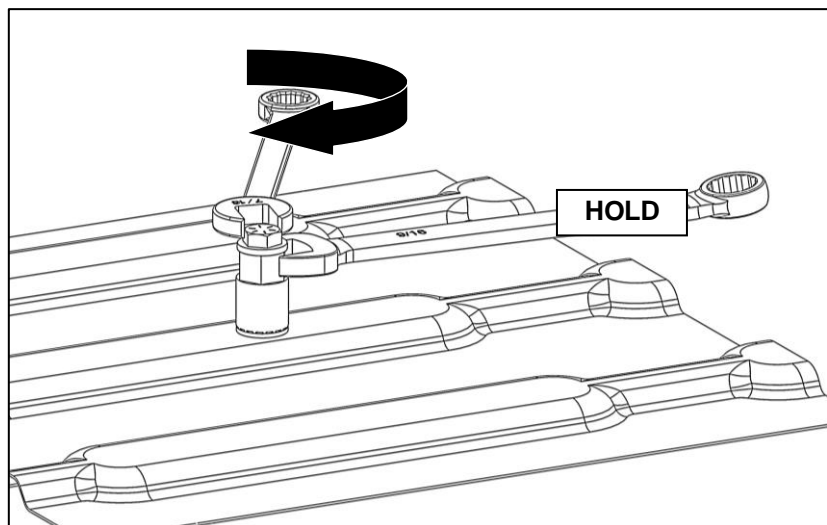
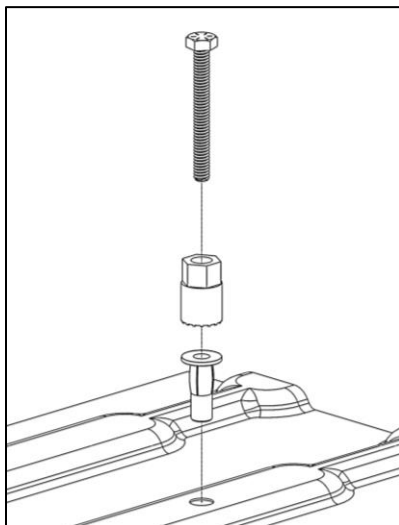

- Using one 1/4"x 1-1/4" bolt, one 1/4" flat washer, and one 1/4" lock washer, bolt the door mount bracket to installed plus nut.
- Align and level shelf.
- Tighten hardware.

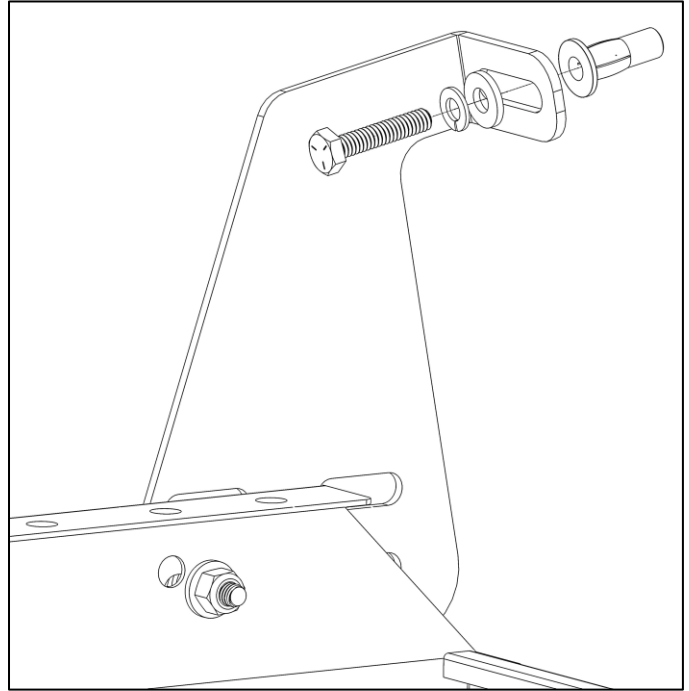

GO BACK AND ENSURE ALL HARDWARE IS TIGHTENED.

INSTALLATION IS COMPLETE.