

Holman

Instruction Guide 4A824

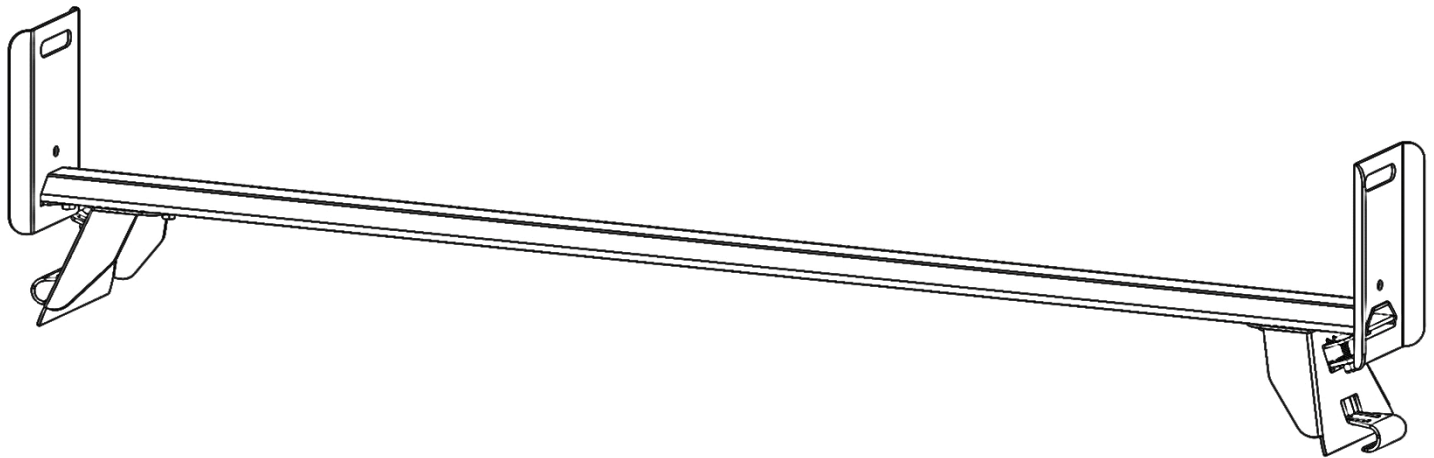

Holman
Rancho Cordova, CA 95742
800-343-7486
InstallationSupport@Holman.com

PLEASE READ ALL INSTRUCTIONS AND WARNINGS PRIOR TO ASSEMBLING, INSTALLING, AND USING THIS PRODUCT.

Warning



ALWAYS SECURE ALL PAYLOADS AND LADDERS PRIOR TO TRANSPORT OR MOVING VEHICLE.

Tools Needed

1/2" Socket and Wrench	1/2" Box Wrench
------------------------	-----------------

Table of Contents

Parts 2

Hardware 2

Step 1 – Modify Existing 4A823 Rack..... 3

 Step 1A – Move 4A823 Front Crossbar 3

 Step 1B – Prepare 4A823 Rear Crossbar 3

 Step 1C – Install Spacers on 4A823 Rack 4

Step 2 – Assemble and Install 4A824 Third Crossbar 4

 Step 2A – Attach Feet to Crossbar 4

 Step 2B – Attach End Stops..... 5

 Step 2C – Install Rack to Vehicle..... 6

 Step 2D – Fasten Foot Assemblies to Crossbows 7

 Step 2E – Tighten Feet to Vehicle 7



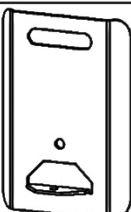
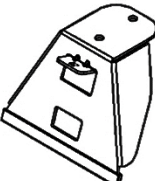
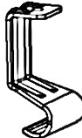

Before You Begin

- Read all instructions prior to assembling or installing any Kargo Master product.
 - **Always locate your installation locations prior to performing any work.**
 - **ENSURE SAFETY WHILE INSTALLING ONTO VEHICLE.**
-

Parts

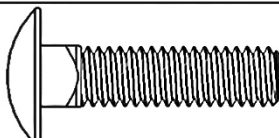
NO.	ITEM	PART NUMBER	DESCRIPTION	QTY.
1		4A820-001	CROSSBAR	1
2		4A820-002	END STOP	2
3		40849C-10	GM Gutter Foot ASM	2
4		11-02085	GM GUTTER CLAMP	2
5		18-4A824	HARDWARE KIT	1

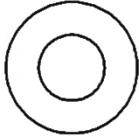
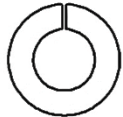
Hardware

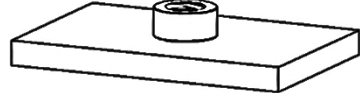
ITEM	HARDWARE TO SCALE	PART NUMBER	DESCRIPTION	QTY.
1		74431	5/16-18 X 1-1/4" CARRIAGE BOLT	2
2		11138689	5/16-18 X 1" HEX HEAD BOLT	6
3		11545144	5/16" FLAT WASHER	8
4		1171067	5/16" LOCKING WASHER	6
5		70861	5/16"-18 NYLOC	2
6	 NOT TO SCALE	4A820-005	SLIDER PLATE	2

Hardware (Continued)

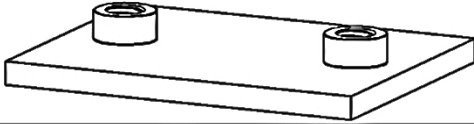
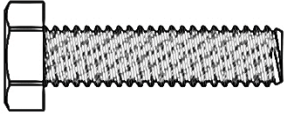
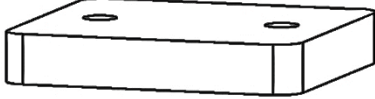
ITEM	HARDWARE TO SCALE	PART NUMBER	DESCRIPTION	QTY.
7	 NOT TO SCALE	4A820-004	MOUNTING PLATE	2
8		11241181	5/16"-18 X 1-1/2" HEX HEAD BOLT	8
9	 NOT TO SCALE	101067	GM CROSSBAR NYLON SPACER	4

DO NOT EXCEED MANUFACTURERS WEIGHT CAPACITY FOR ROOF.

Step 1 – Modify Existing 4A823 Rack

Step 1A – Move 4A823 Front Crossbar

- Loosen 5/16" hardware between front feet and gutter clamps.
- Move front crossbar assembly to desired position. Typical distance between front and rear crossbars is 78 inches when 4A824 additional crossbar installed.
- **LOOSELY** tighten 5/16" hardware between front feet and gutter clamps.

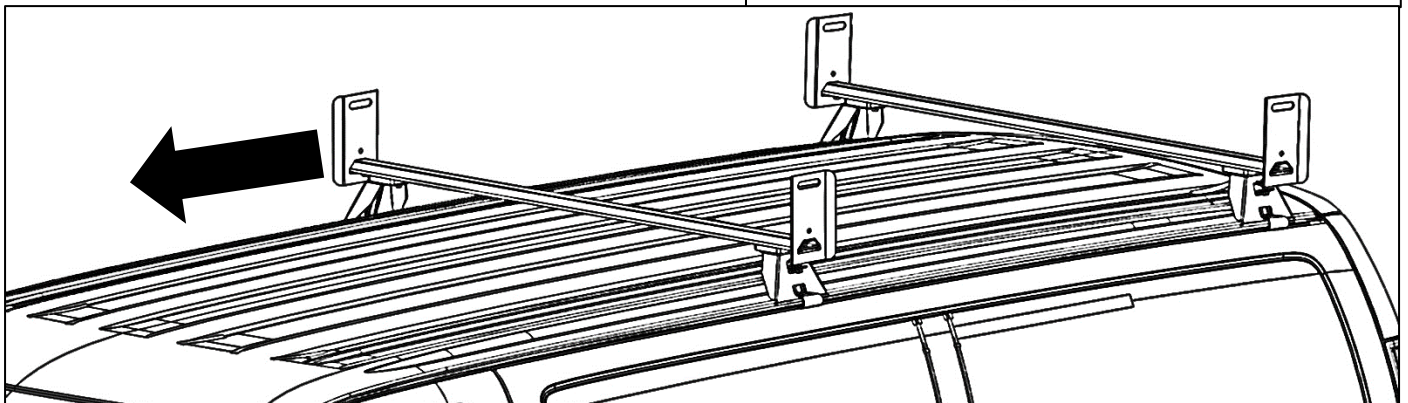
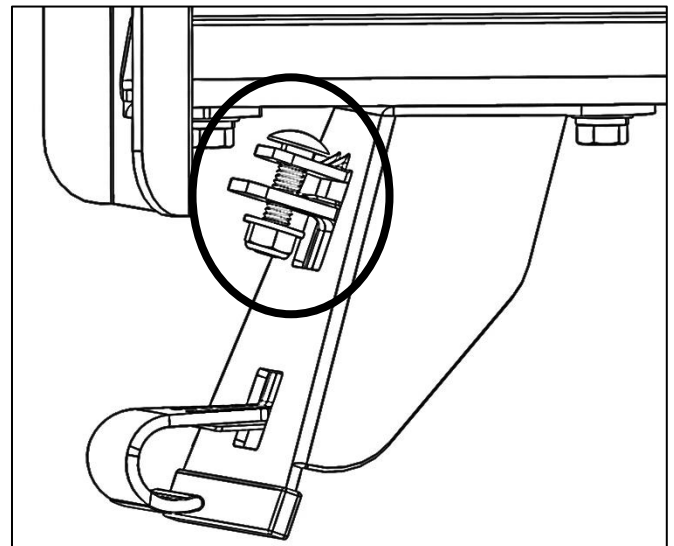

Step 1B – Prepare 4A823 Rear Crossbar

- Loosen 5/16" hardware between rear feet and gutter clamps.

Step 1C – Install Spacers on 4A823 Rack

- For each foot on existing rack, remove washers that are clamping foot to crossbar.
- Insert spacer between foot and crossbar.
- Using 5/16" x 1-1/2" hex head bolts provided and previously removed 5/16" lock washers and 5/16" flat washers, bolt through foot and spacer into mounting plate.
- Snug tighten but allow for movement.

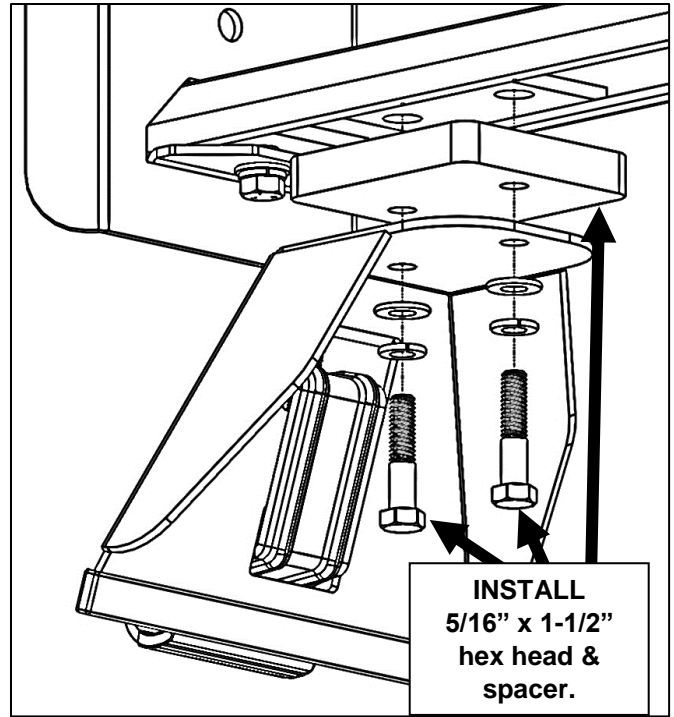
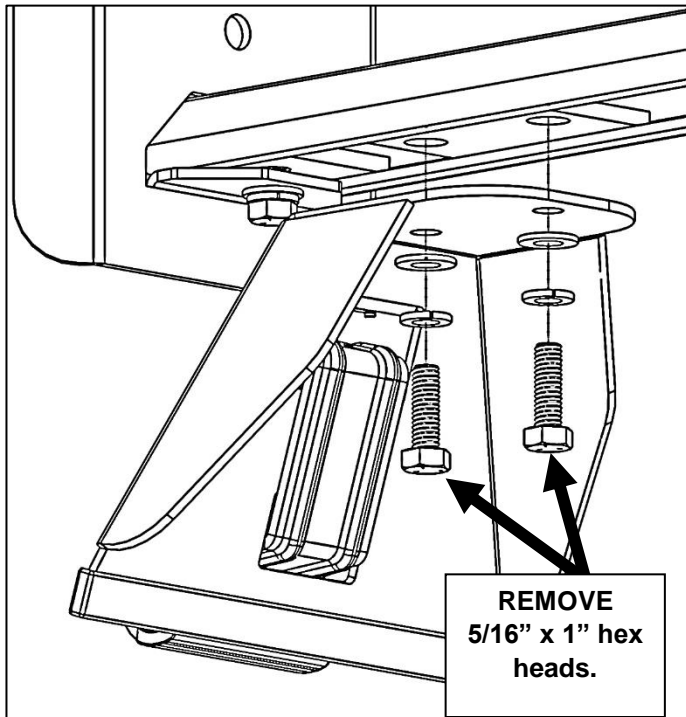

Step 2 – Assemble and Install 4A824 Third Crossbar

Step 2A – Attach Feet to Crossbar

- Using a 5/16"-18 x 1" hex head bolt, 5/16" lock washer, and 5/16" flat washer, **LOOSELY** bolt a mounting plate to a foot assembly. The press nuts on the mounting plate face up.
- **DO NOT TIGHTEN. KEEP FEET LOOSE.**
- Repeat for remaining mounting plate and foot assembly.

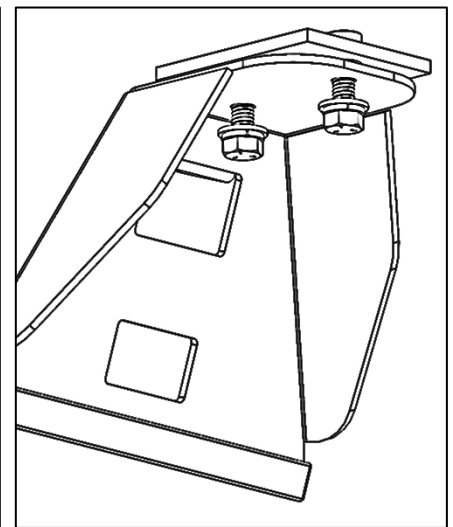
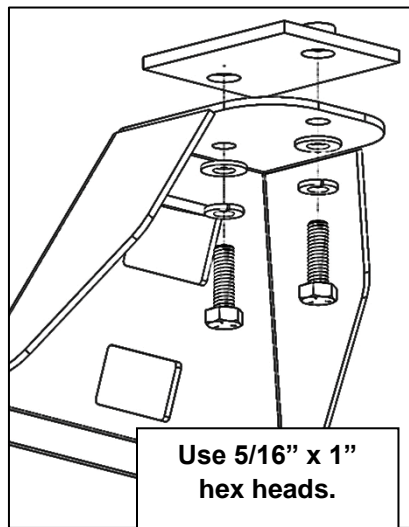

- Slide an assembled foot assembly onto the crossbar with the slanted face facing outward.
- **DO NOT TIGHTEN.**
- Repeat for opposite side of cross bar.

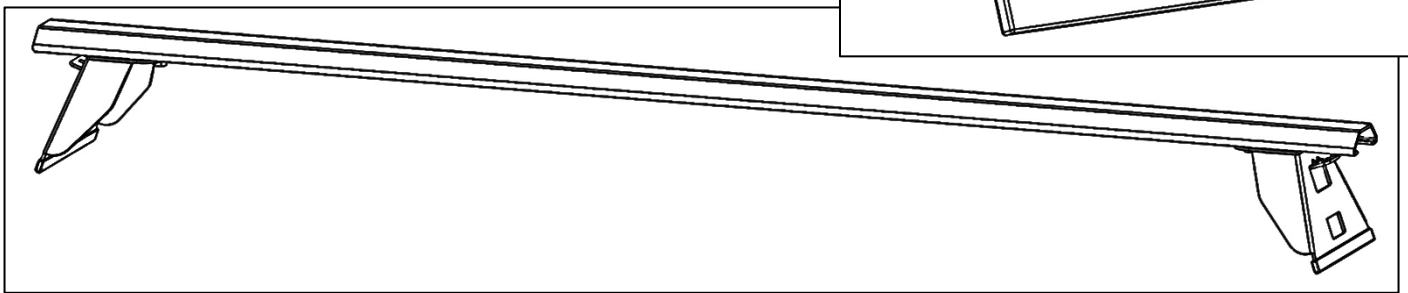
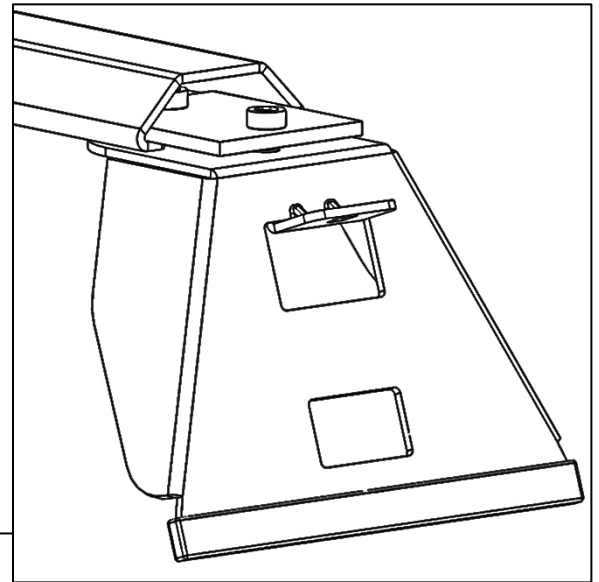

Step 2B – Attach End Stops

- Using a 5/16"-18 x 1" hex head bolt, 5/16" lock washer, and 5/16" flat washer, **LOOSELY** bolt a slider plate to an end stop. The press nuts on the slider plate face up. **DO NOT TIGHTEN.**
- Repeat for remaining end stop.

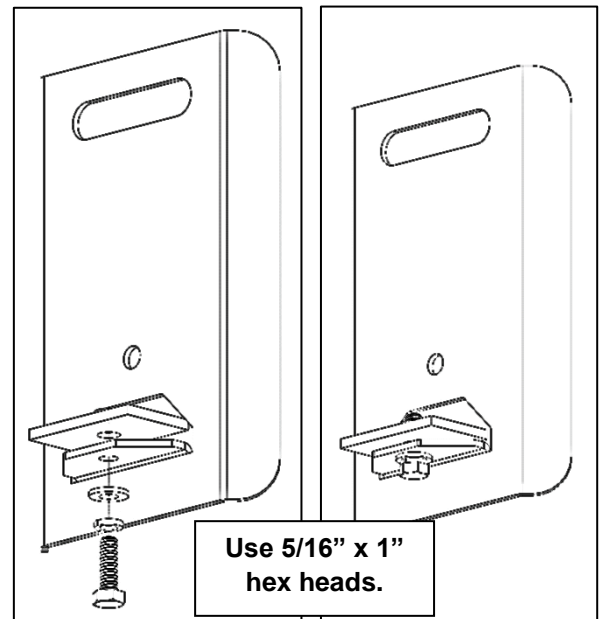
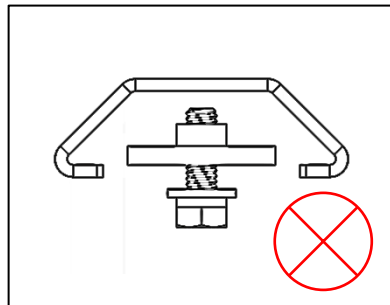
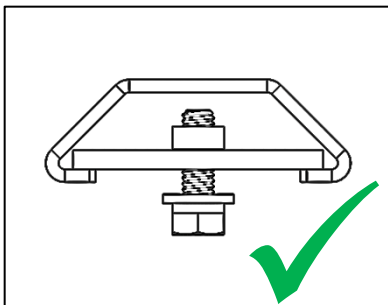

- Slide an assembled end stop onto a crossbar with the angled flanges facing outward until slider plate aligns with end of crossbar. **Be sure to insert slider plate so it cannot rotate.**
- TIGHTEN hardware securing end stop to end of crossbar.
- Repeat for opposite side of cross bar.

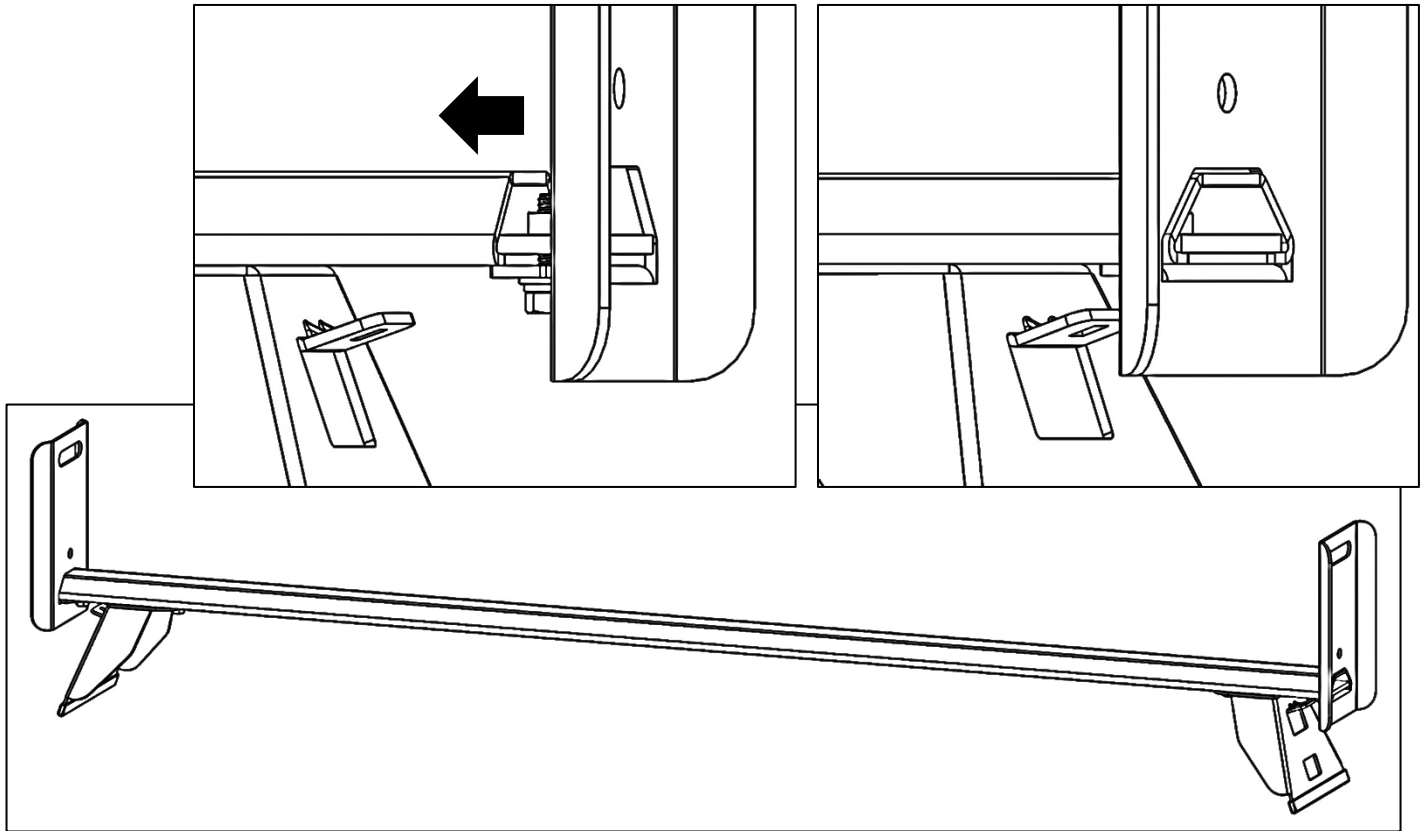

Step 2C – Install Rack to Vehicle

- Set crossbar assembly on vehicle. Be sure feet are inside rain channel on roof and clips are outside vehicles roof rain gutter.
- Center feet and rack to vehicle.
- Position crossbar midway between front and rear crossbars.

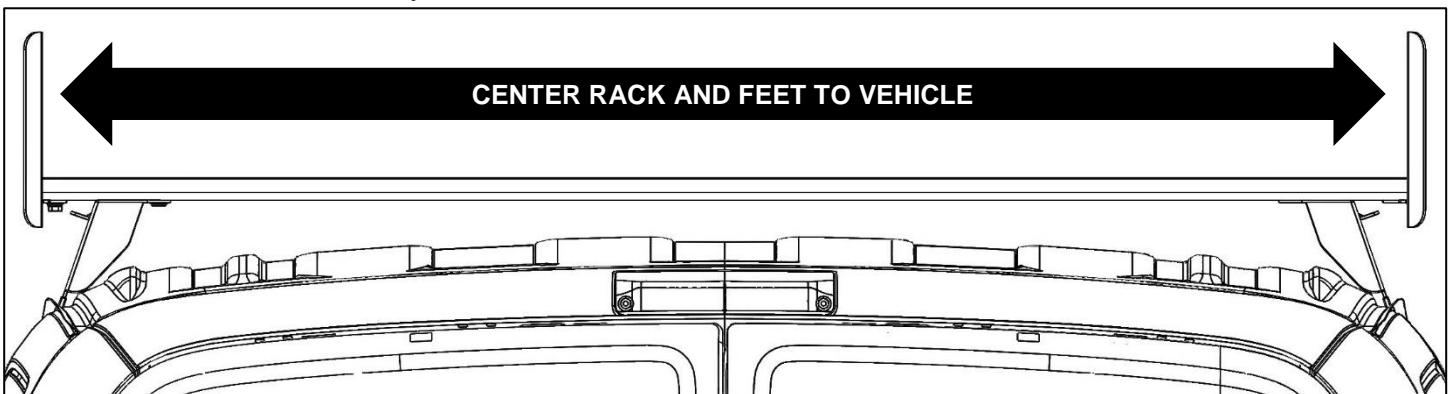

Step 2D – Fasten Foot Assemblies to Crossbows

- Insert gutter clamp through the gutter foot rectangular slots as shown.
- Position gutter clamp on underside of vehicle rain gutter.
- LOOSELY clamp the vehicle rain gutter between the gutter clamp and the foot using a 5/16" x 1-1/4" carriage bolt, 5/16" flat washer, and 5/16" lock nut. **DO NOT TIGHTEN.**
- While squeezing the gutter clamp and foot to each side of vehicles roof rain gutter, tighten foot to crossbow.
- Repeat for all other feet.

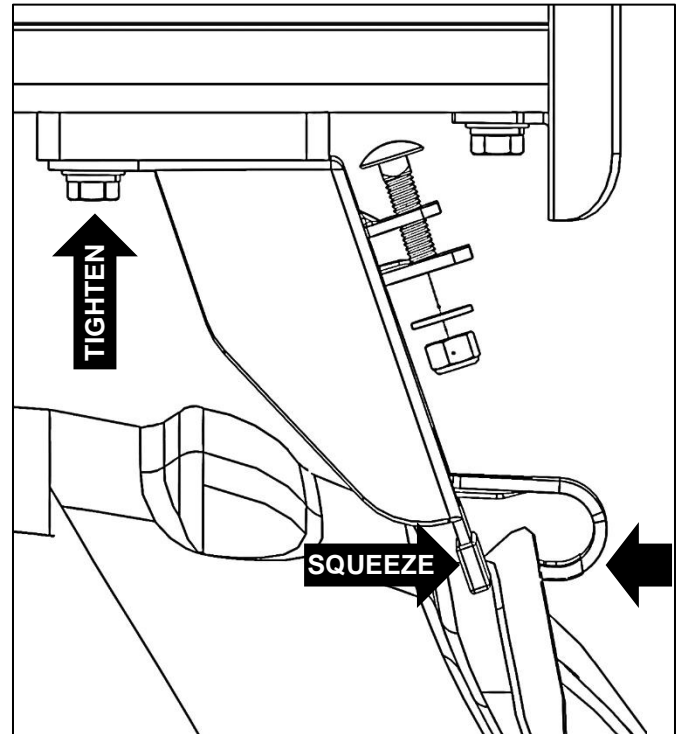
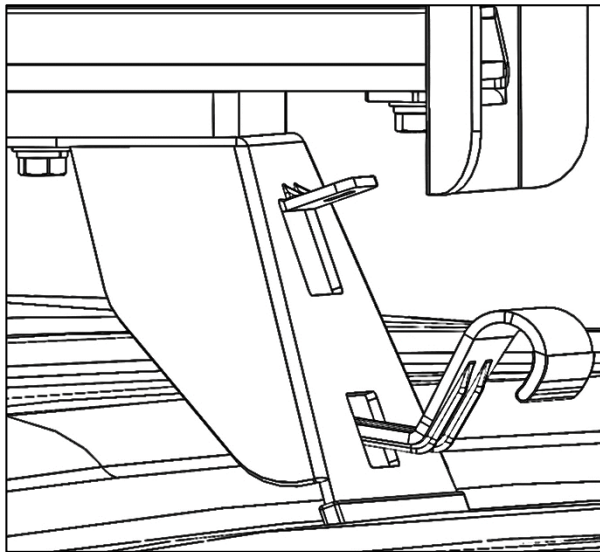

Step 2E – Tighten Feet to Vehicle

- Tighten 5/16" lock nut until foot is securely clamped between to vehicle.
- Repeat for remaining gutter clamps and feet.

GO BACK AND TIGHTEN ALL HARDWARE.

INSTALLATION AND ASSEMBLY ARE COMPLETE.

