

Holman

Instruction Guide 4A95C

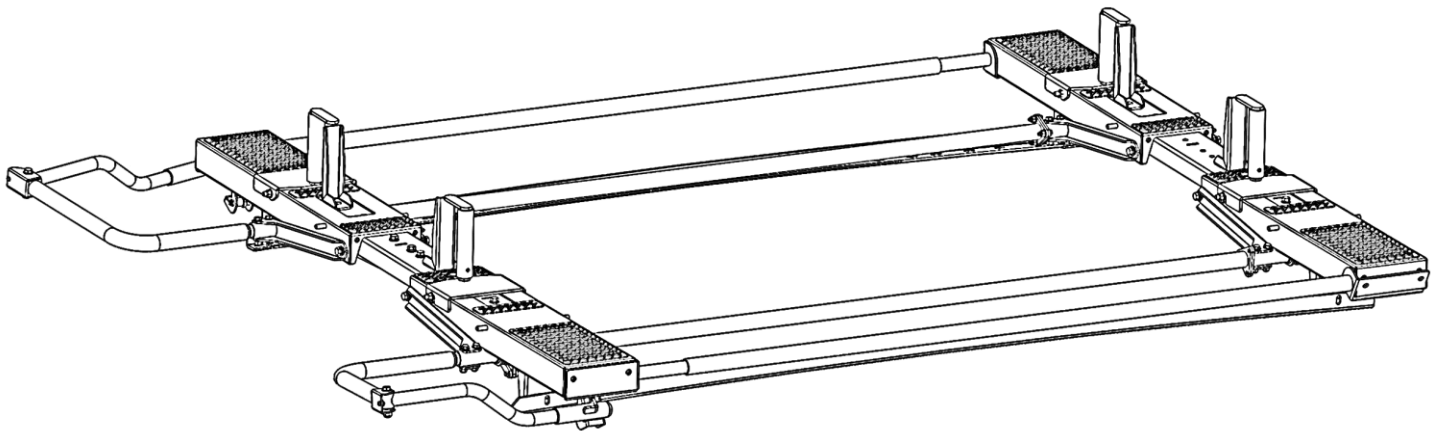

Holman
Rancho Cordova, CA 95742
800-343-7486
InstallationSupport@Holman.com

PLEASE READ ALL INSTRUCTIONS AND WARNINGS PRIOR TO ASSEMBLING, INSTALLING, AND USING THIS PRODUCT.

Warning



Always check for wires, fuel tanks and lines, brake lines and other important vehicle functionality items prior to drilling and installing all products.

DO NOT EXCEED MANUFACTURERS WEIGHT CAPACITY FOR ROOF.

Tools Needed

5/16" Wrench and Socket	3/8" Wrench and Socket
1/2" Wrench and Socket	1/2" Wrench and Socket
Tape Measure	

Table of Contents

Before You Begin 1

Parts List..... 2

Hardware 3

Step 1A – ProMaster City Rail Installation 5

Step 1B – NV200/City Express Rail Installation..... 6

Step 1C – Transit Connect Rail Installation 7

Step 1D – Metris Rail Installation..... 8

Step 2 – Identify Front and Rear Bows 9

Step 3 – Mount Feet to Rails 9

Step 4 – Place Bows on Feet 10

Step 5 – Install Torque Tubes..... 12

Step 6 – Install Ladder Pan Stiffeners 13

Step 7 – Determine Ladder Stop Locations 14

Step 8 – Install Latches 16





Step 9 – Install Handle..... 16

Step 10 – Assemble Ladder Hooks 17



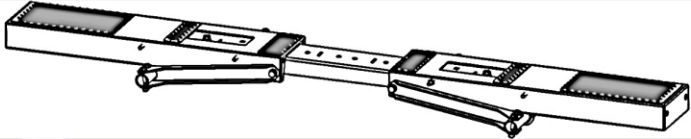
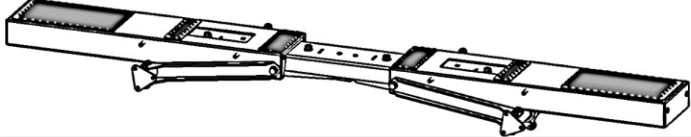
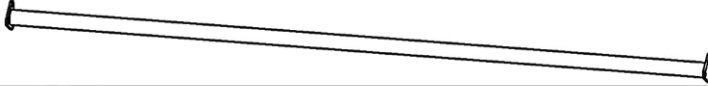
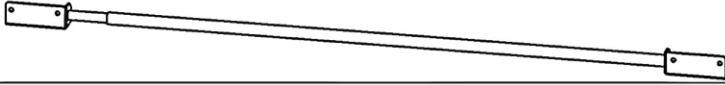
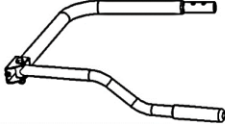
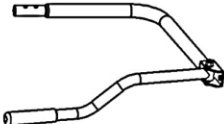
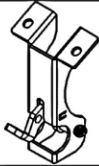
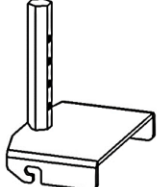





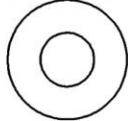

Before You Begin

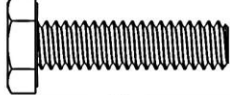
- Read all instructions prior to installing any Holman product.
- **Find your vehicle roof rail mounting locations prior to rack assembly.**
- **Be sure to apply sealant in the following location.**
 - Between roof and mounting rails, and around the holes in the roof.
 - Around all threads entering cargo area.
 - Between the rubber spacer and roof of vehicle to prevent water from leaking into cargo area.
 - Around all swage joints to avoid water from leaking inside of ladder rack.

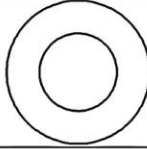

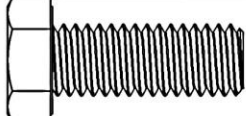
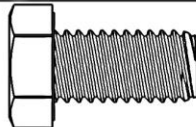
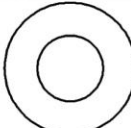
Parts List

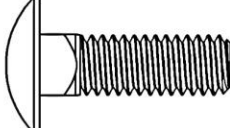
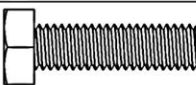
ITEM NO.	ITEM	PART NUMBER	DESCRIPTION	QTY.
1		4A95C-FRONT	FRONT BOW ASM	1
2		4A95C-REAR	REAR BOW ASM	1
3		4A93L-50	TORQUE TUBE, 71.5" LR	2
4		4A93L-7	SUPPORT TUBE ASSY	2
5		4A98L-40	ASSEMBLY, HANDLE, DROP DOWN, MINI	1
6		4A97L-40	ASSEMBLY, HANDLE, DROP DOWN, MINI	1
7		4A92L-44	LATCH ASSY.	2
8		4A900-36	BASE LADDER HOOK WELDMENT	4
9		4A900-35	LADDER HOOK	4
10		4A900-30-004	LADDER STOP	4
11		4A800-02	COMPACT VAN MOUNTING RAIL	2
12		4A933-10	5.5" ALUMINUM FOOT	4
13		18-4A95C	HARDWARE	1

Hardware

ITEM	HARDWARE TO SCALE	PART NUMBER	DESCRIPTION	QTY.
1		11541082	1/4 FLAT WASHER	34
2		33618	1/4" LOCK WASHER	10
3		0169789	1/4-20 NYLOC NUT	12
4		110120304	1/4-20 X 1" HEX HEAD	16
5		0123496	3/8 LOCK WASHER	16
6		11541089	3/8" STEEL FLAT WASHER	20
7		0169791	3/8"-16 LOCK NUT	2
8		11241197	3/8-16 X 1" HEX HEAD BOLT	10
9		11241196	3/8-16 X 3/4" HEX HEAD BOLT	8
10		33080	5/16" FLAT WASHER	12
11		0169777	5/16"-18 LOCK NUT	8
12		21811	5/16-18 X 1" CARRIAGE BOLT	8
13		38560	M6 X 1.0 X 22MM HEX HEAD BOLT	6
14		91263A839	M6-1 X 20MM FLAT HEAD CAP SCREW	4

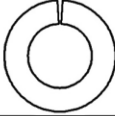
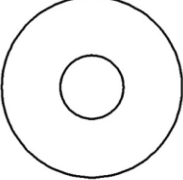
Hardware (Continued)

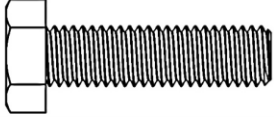
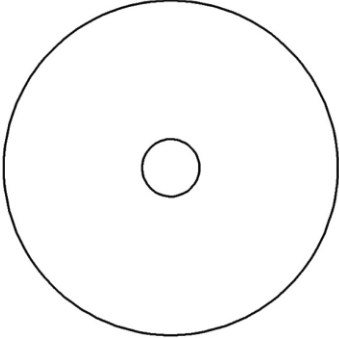
ITEM	HARDWARE TO SCALE	PART NUMBER	DESCRIPTION	QTY.
15			5/16" LOCKING WASHER	4
16			5/16" FENDER WASHER	4
17		11511017	M8-1.25mm NYLON NUT	4
18		11552488	M8X30 HEX HEAD	4
19			5/16" RUBBER FENDER WASHER, 1-3/4" OD X 1/8" THK	6
20			SEALANT	1

DO NOT EXCEED MANUFACTURERS WEIGHT CAPACITY FOR ROOF.

Step 1A – ProMaster City Rail Installation

- Locate the 6 mounting locations shown on roof of van.
- Remove plugs from roof.
- Place the rail on the roof so the holes align with the threaded holes in roof. In most installs, the rail upright flange is to the outside of the van.

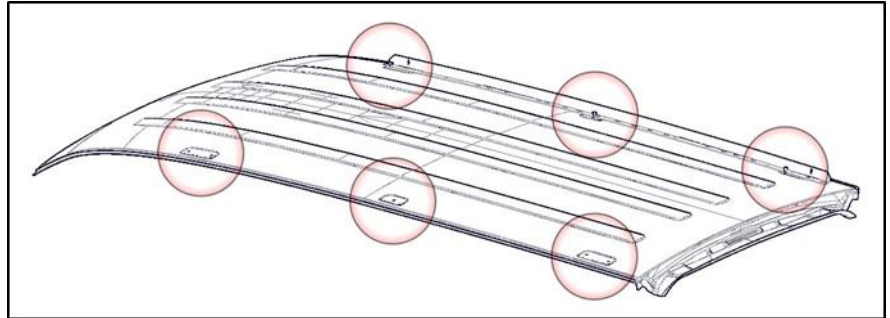

- Insert rubber washer between the mounting rail and the roof to ensure sealing.
- Place sealant on and around threaded holes and bolt threads to seal roof. (Passenger side shown)
- Install mounting rail as shown using M6 x 22mm bolts, 1/4" lock washers, and 1/4" flat washers. **Be sure to apply sealant around bolts as you fasten them.**

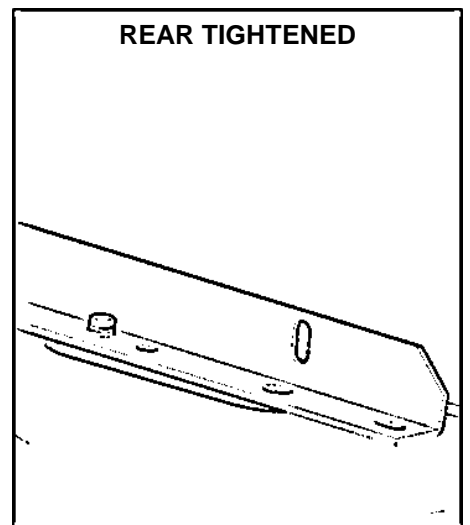
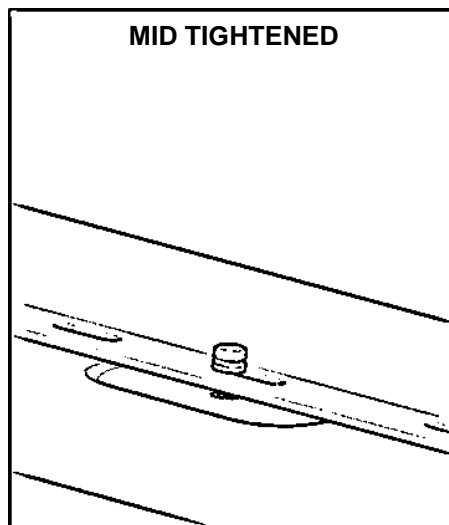
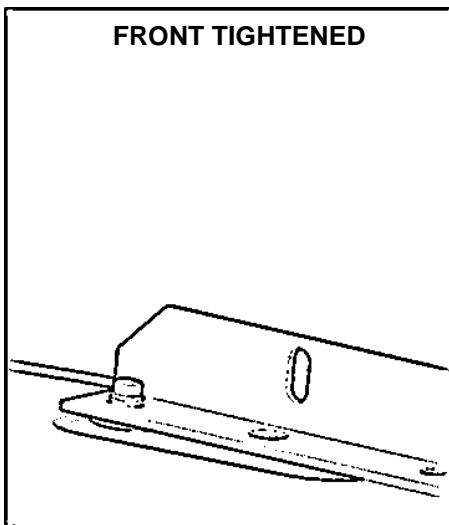
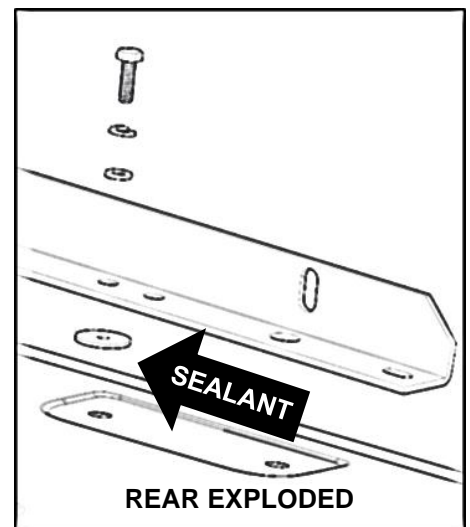
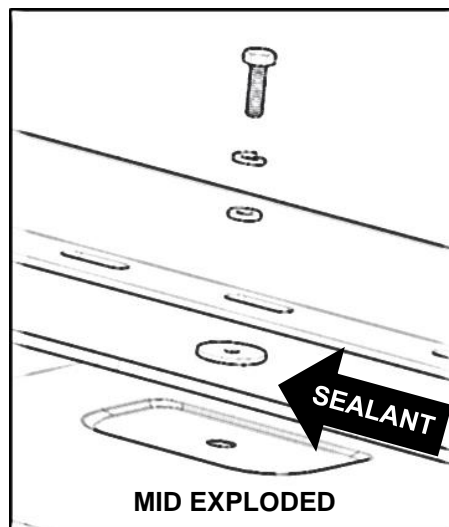
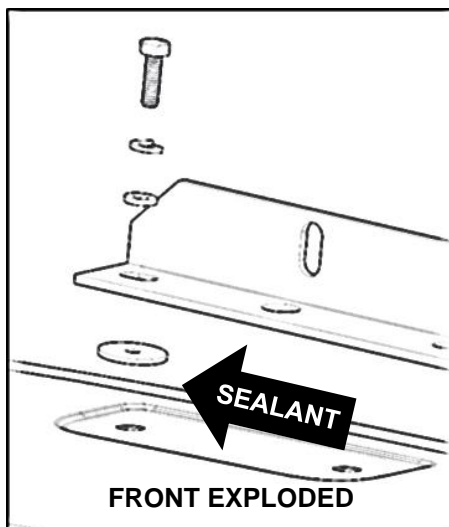

DO NOT EXCEED MANUFACTURERS WEIGHT CAPACITY FOR ROOF.

Step 1B – NV200/City Express Rail Installation

- Locate the 4 mounting locations shown on roof of van.
- Remove plugs from roof.
- Place the rail on the roof so the holes align with the threaded holes in roof and with approximately 1" between the rear of the rail and the rear door opening. In most installs, the rail upright flange is to the outside of the van.
- Insert rubber washer between the mounting rail and the roof to ensure sealing.
- Apply sealant on and around threaded holes and bolts threads to seal roof. (Passenger side shown)
- Install mounting rail as shown using M8 x 30mm bolts, 5/16" lock washers, and 5/16" flat washers. **Be sure to apply sealant around bolts as you fasten them.**

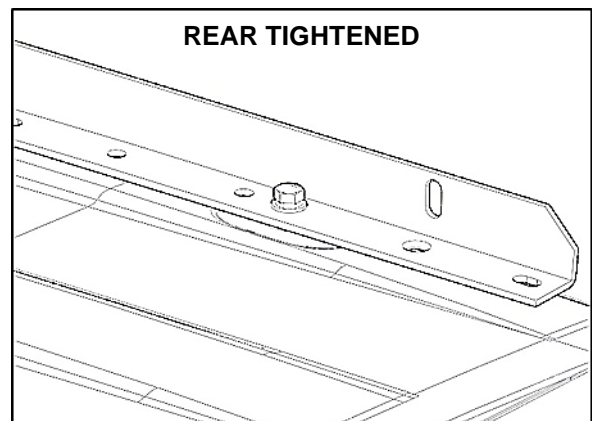
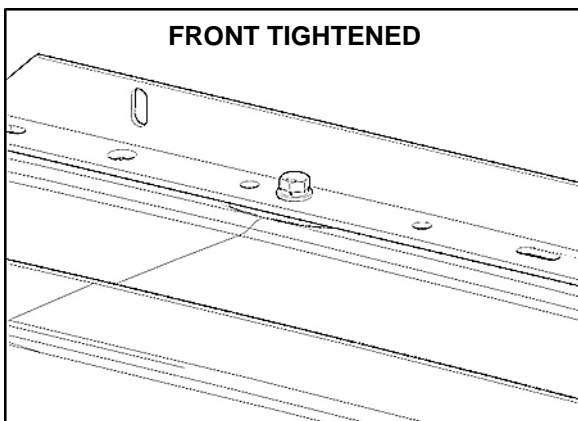
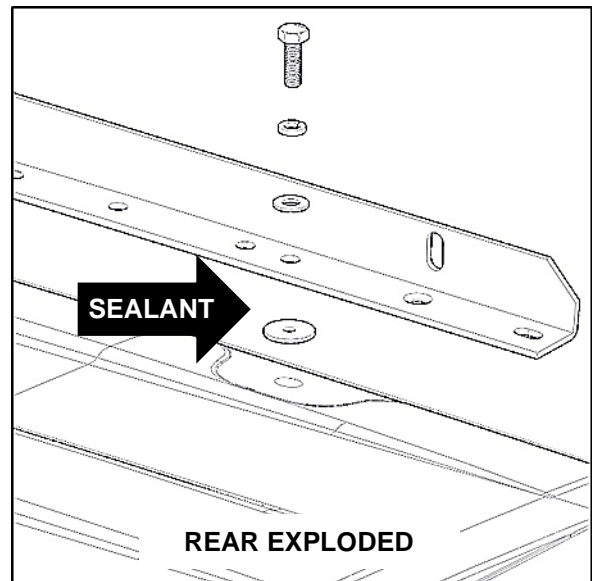
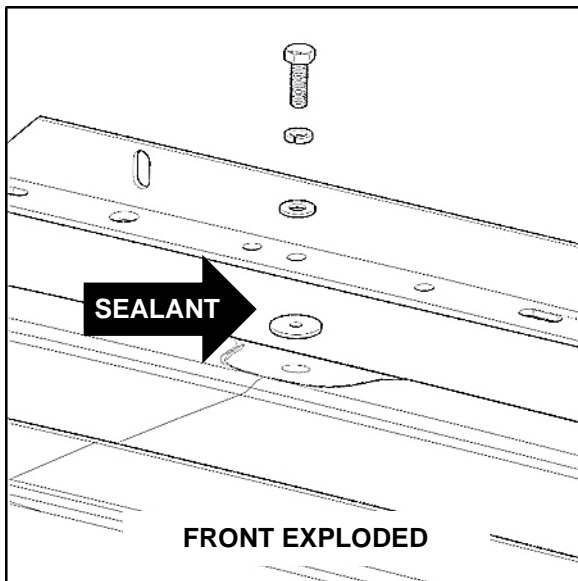
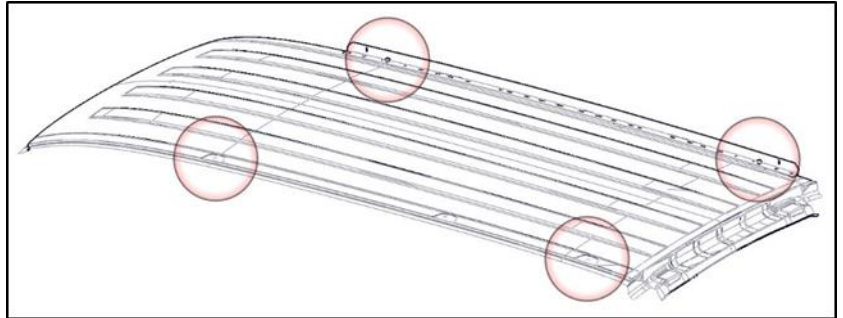

DO NOT EXCEED MANUFACTURERS WEIGHT CAPACITY FOR ROOF.

Step 1C – Transit Connect Rail Installation

- Locate 4 mounting locations shown on roof of van.
- Remove plugs from roof.
- Place the rail on the roof so the holes align with the threaded holes in roof and with approximately 1" between the rear of the rail and the rear door opening. In most installs, the rail upright flange is to the outside of the van.
- Insert rubber washer between the mounting rail and the roof to ensure sealing.
- Apply sealant around holes in the roof and around bolt threads to seal roof. (Passenger side shown)
- Install mounting rail as shown using M8 x 30mm bolts and 5/16" flat washers on the outside. Use the 5/16" fender washer and M8 lock nut on the inside of the van. **Be sure to apply sealant on and around threads to seal roof.**

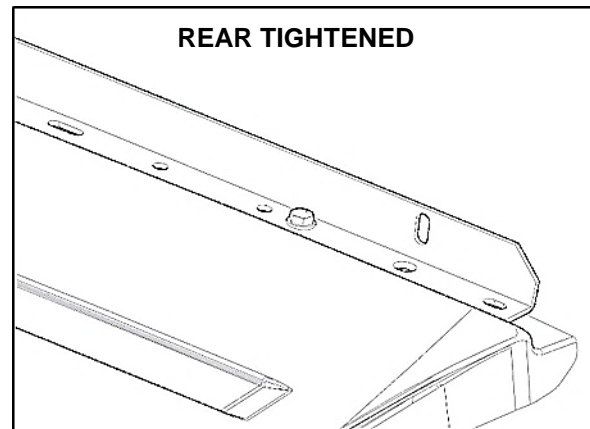
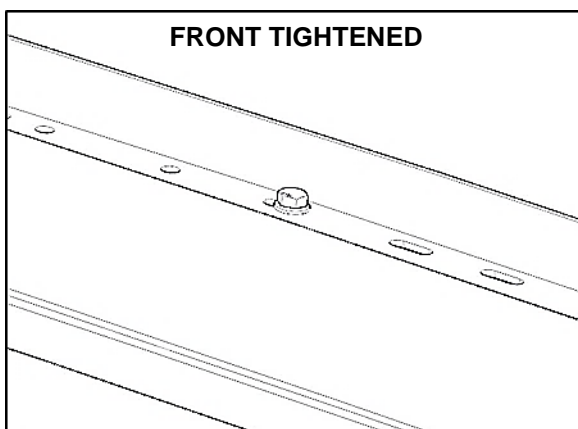
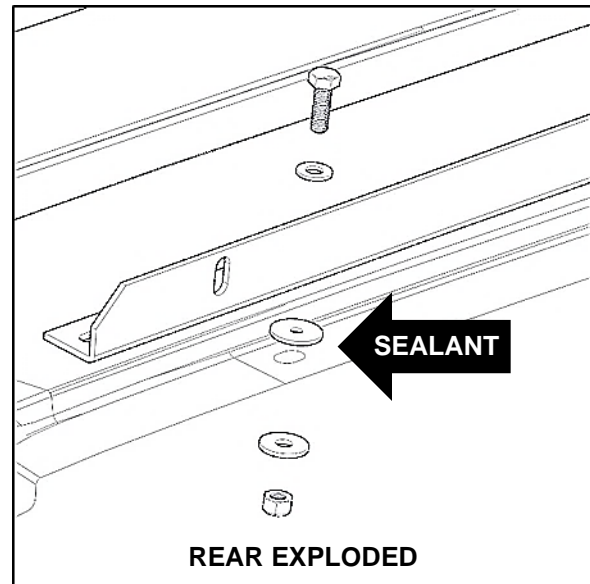
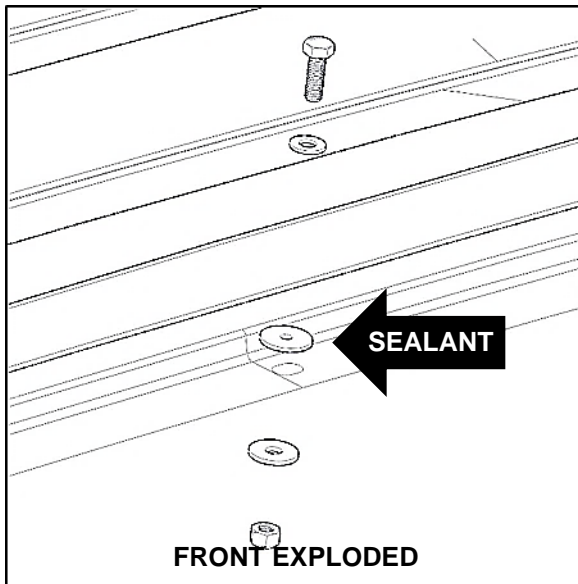
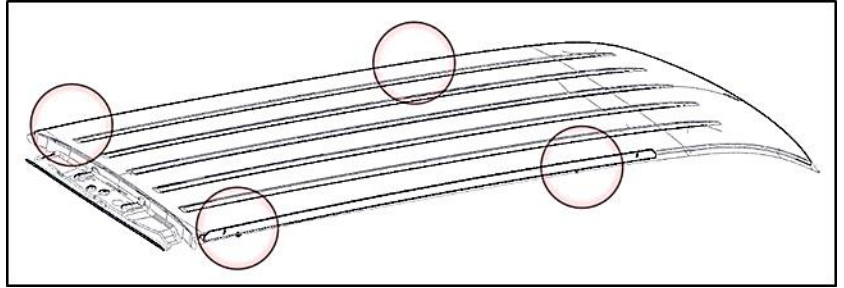

DO NOT EXCEED MANUFACTURERS WEIGHT CAPACITY FOR ROOF.

Step 1D – Metris Rail Installation

- Locate 6 mount locations on van roof, 4 rear and 2 mid-roof, as shown.
- Remove plastic cap in these locations indicated to expose threads in the roof.
- Place the rail on the roof so the holes align with the threaded holes in roof and with approximately 5" between the rear of the rail and the rear door opening. In most installs, the rail upright flange is to the outside of the van.
- Insert rubber washer between the mounting rail and the roof to ensure sealing.
- Apply sealant on and around threaded holes and bolt threads to seal roof. (Passenger side shown)
- Install mounting rail as shown using M6 x 22mm bolts, 1/4" lock washers, and 1/4" flat washers on the outside. **Be sure to apply sealant around bolts as you fasten them.**

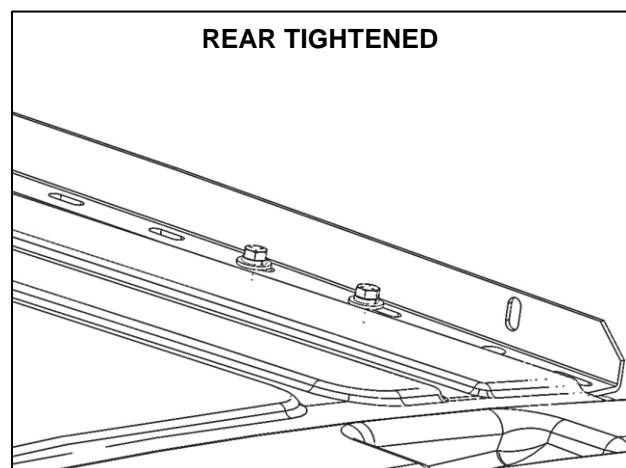
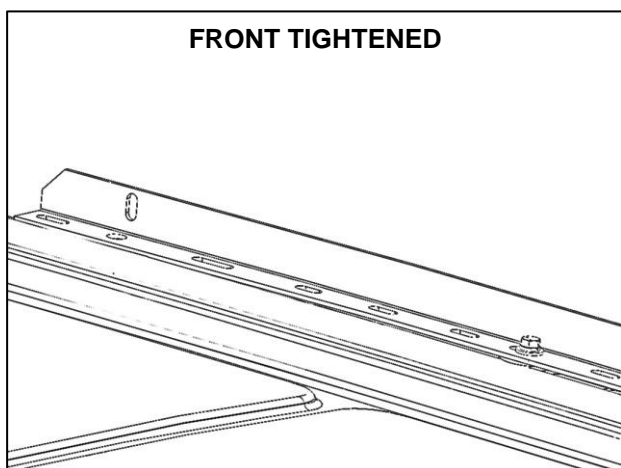
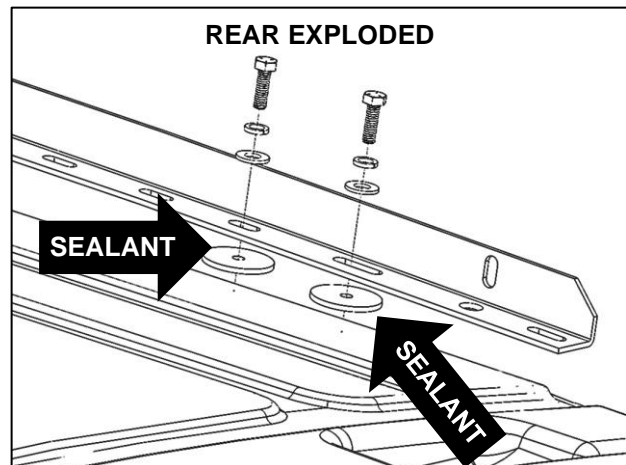
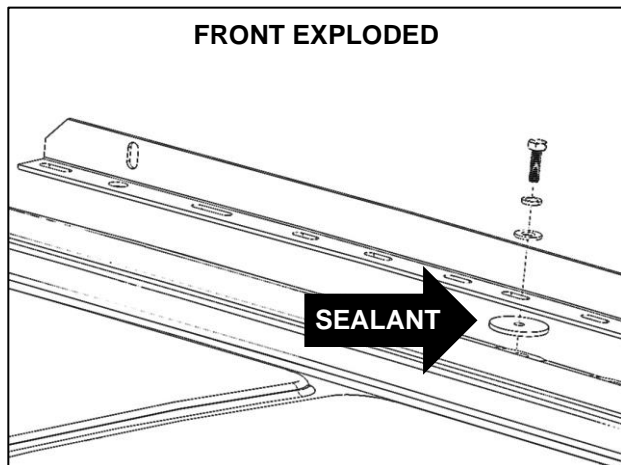
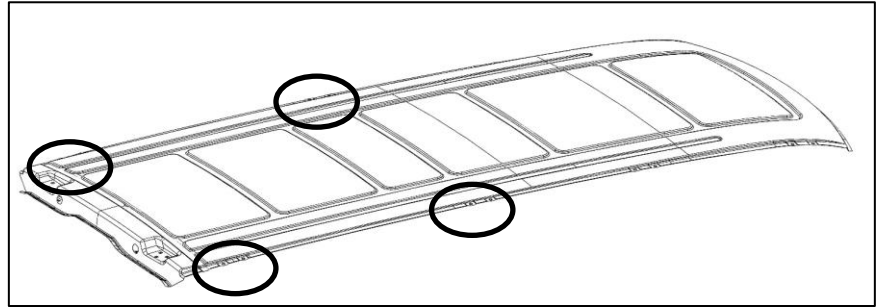

Step 2 – Identify Front and Rear Bows

- Determine front and rear bow. The rear bow will have a dampening mechanism attached. Notice the location of the triangular piece.

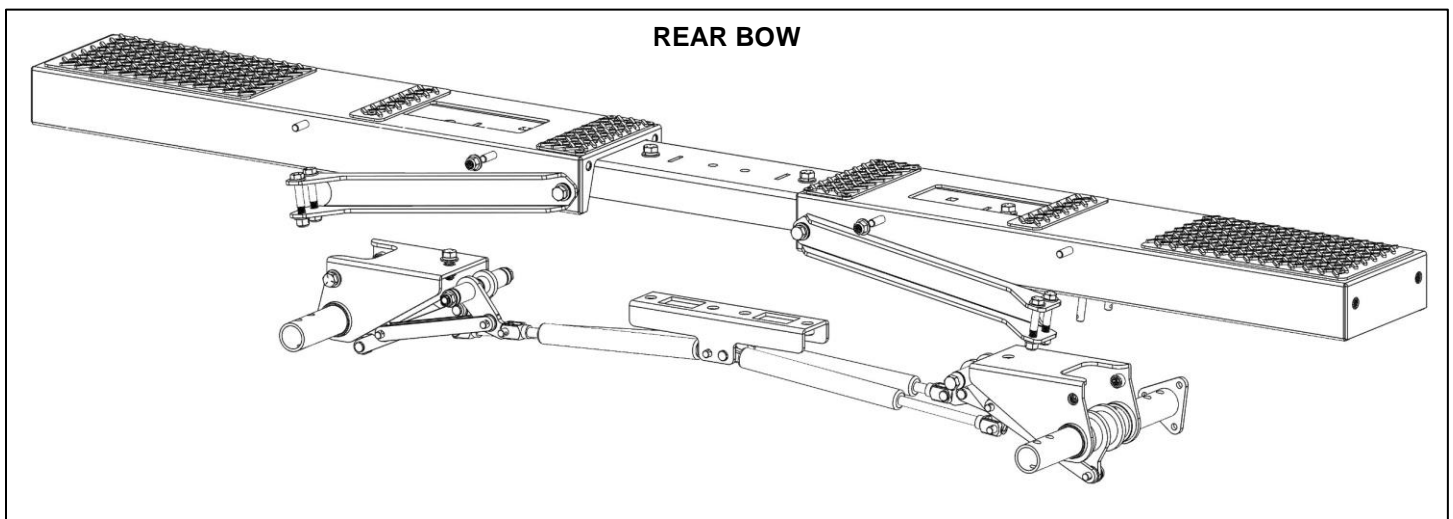
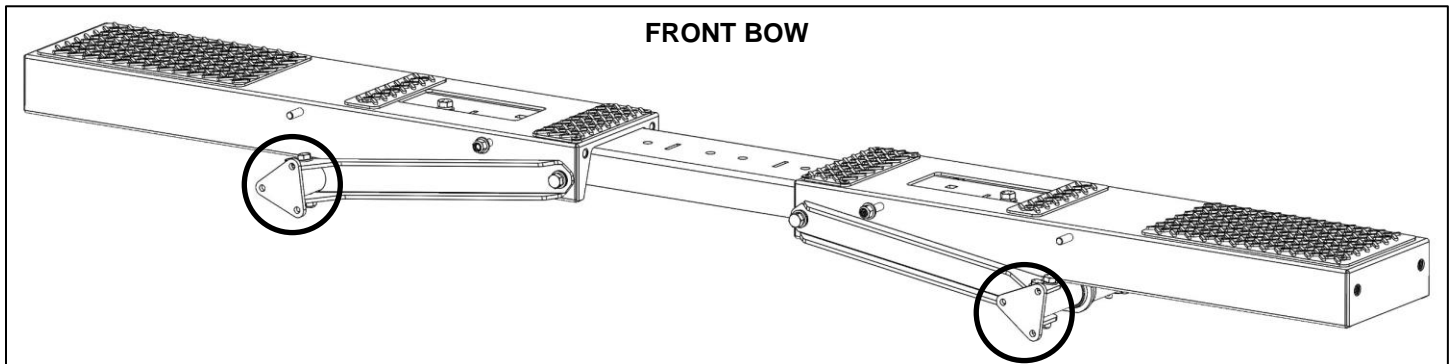

Step 3 – Mount Feet to Rails

- Locate the four mounting locations on the mount rails as shown below.

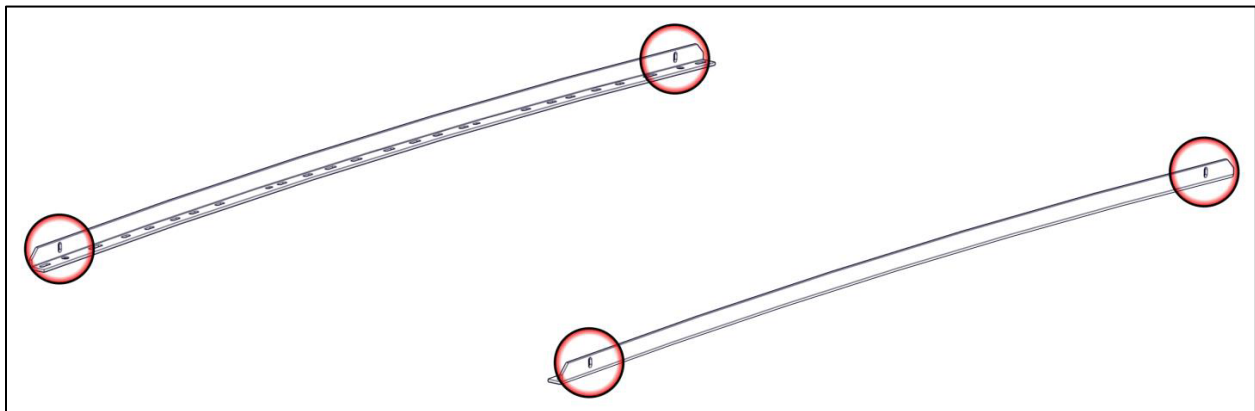

- Using 5/16" x 1" carriage bolts, 5/16" flat washers and 5/16" lock nuts, bolt a foot to the mount rail in the orientation shown.
- Repeat for remaining 3 feet.

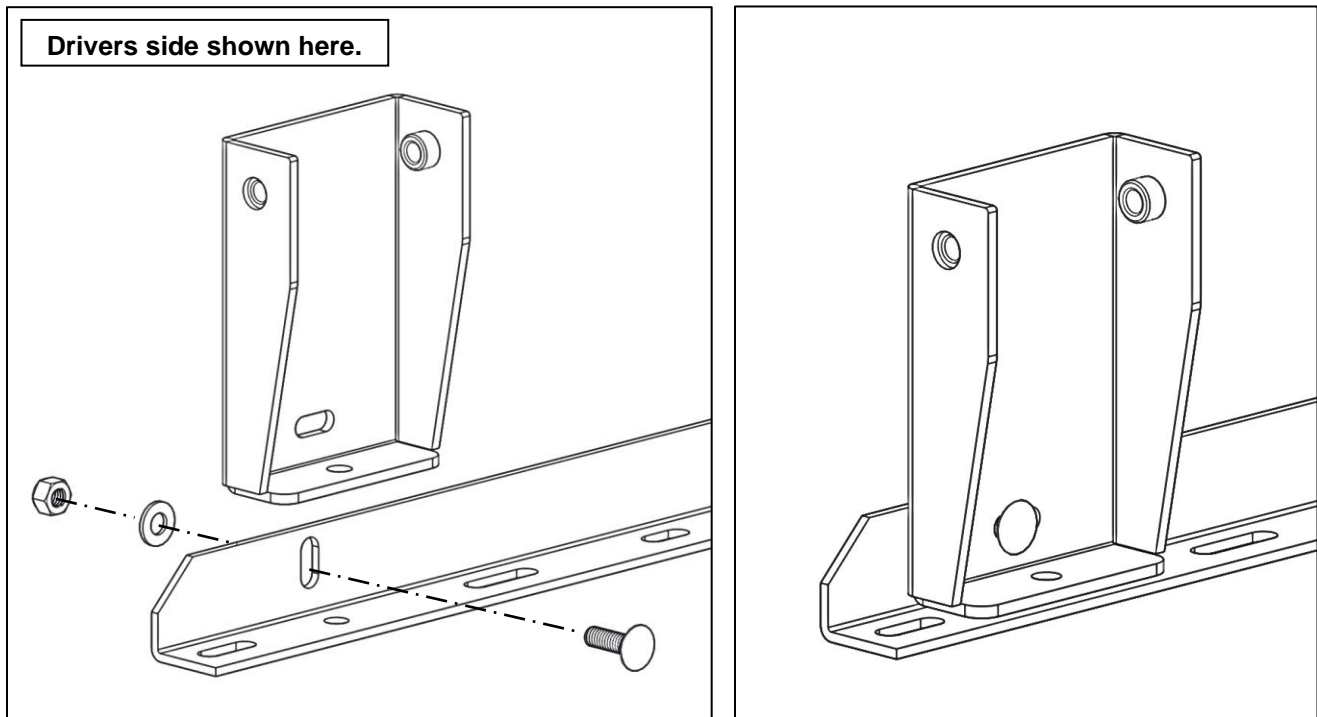

Step 4 – Place Bows on Feet

- Place the front bow on top of the front most mounts on the vehicle and the rear bow on the rear most mounts.
- **Be sure there is an equal distance from the center of the cross bow to each foot as shown below.** The same slot, but on opposite ends of the bow should be used.

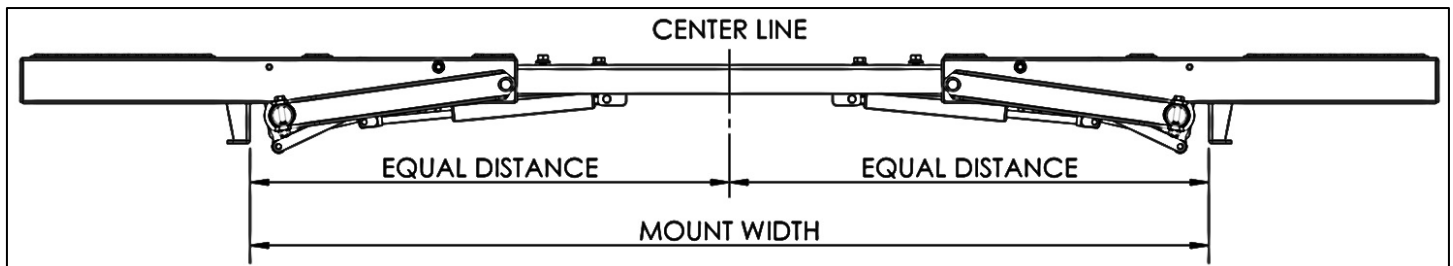

- Rotate the pan to expose the slots in the bow. Place a foam block from the packaging to hold the pan in an up position in order to access the mounting slots.
- Using 3/8" x 1" hex head bolts, 3/8" split lock washers and 3/8" flat washers, attach the bow to foot as shown.
- **DO NOT tighten hardware.** Leave hardware loose until the rack is assembled.
- Repeat these steps for installing to remaining feet on each side of each bow.

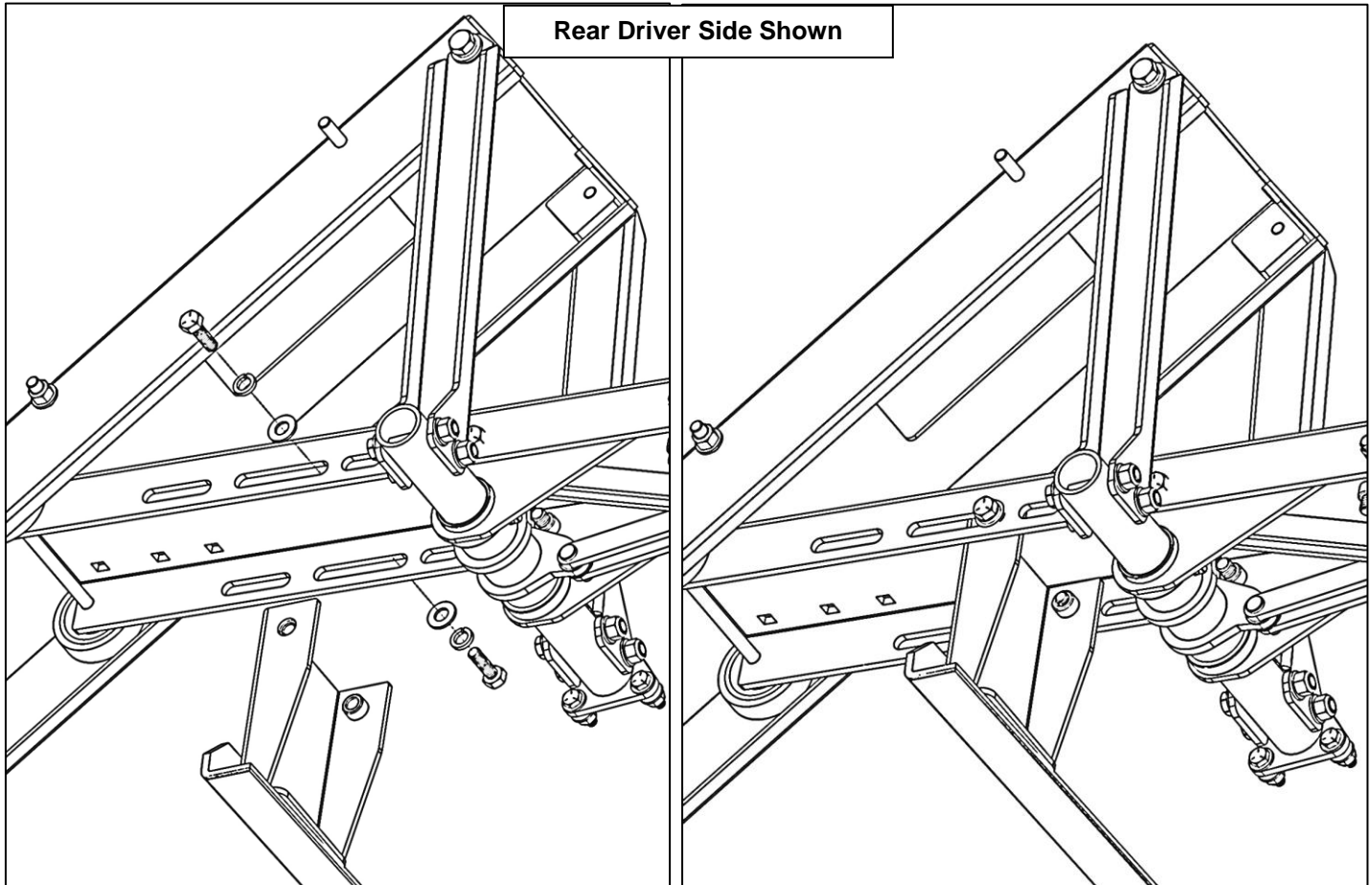

Step 5 – Install Torque Tubes

- Bolt the torque tube to the front and the rear bow using a 1/4" x 1" hex head bolt, two 1/4" flat washers and a 1/4" lock nut at each of the 3 holes through triangular ends of torque tube and actuator on bow.
- Repeat for second torque tube on opposite side of rack.

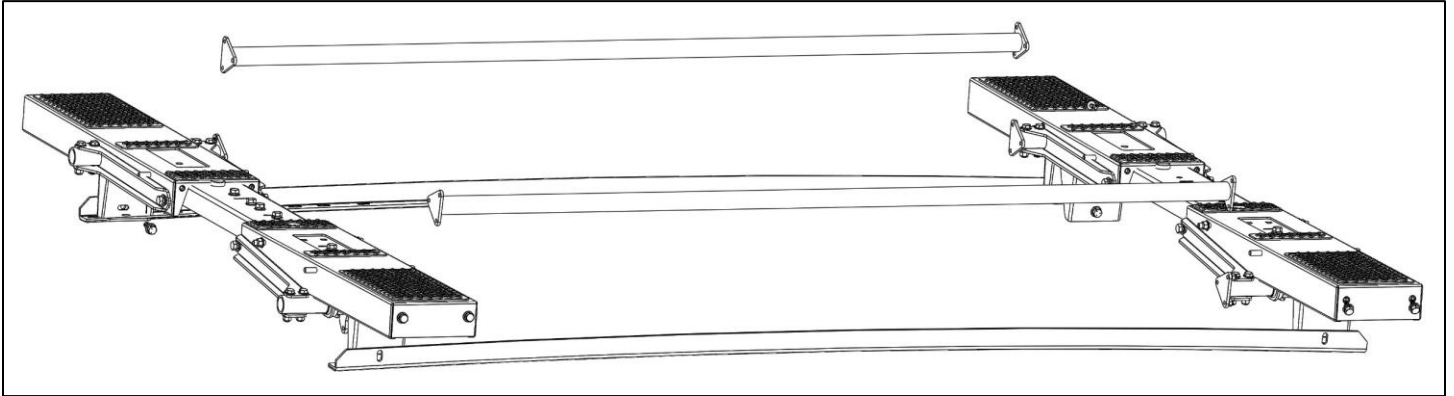

- Snug tighten but allow for movement. This hardware is best tightened after installation.

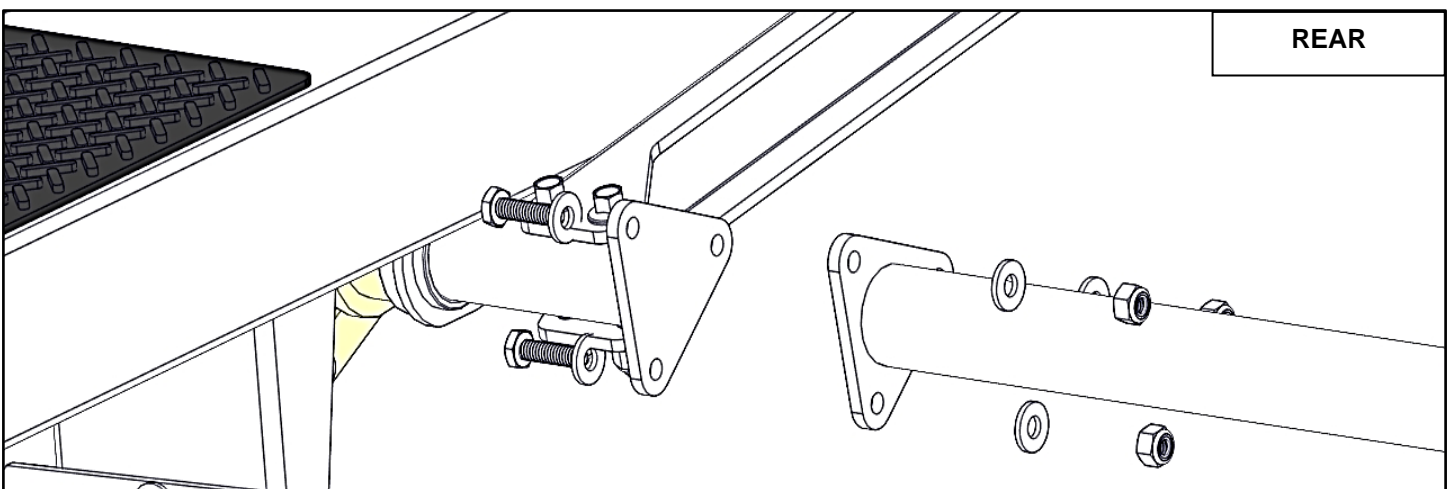
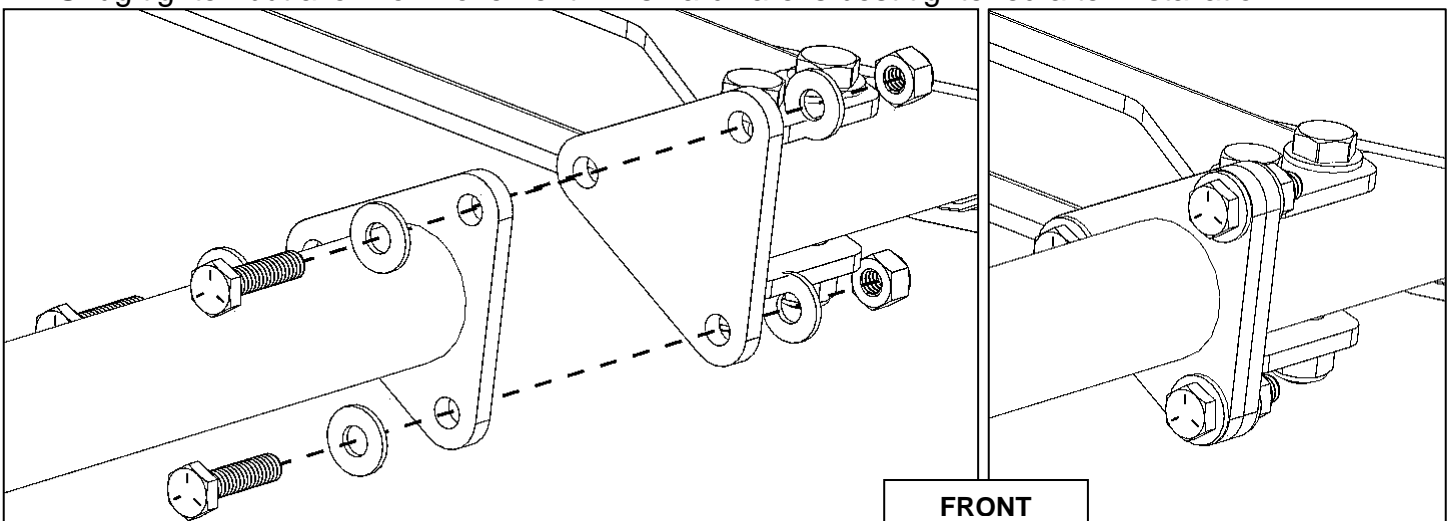

Step 6 – Install Ladder Pan Stiffeners

- Using 3/8" x 3/4" hex heads, 3/8" lock washers and 3/8" flat washers, install ladder pan stiffener to the ends of the bow pan assembly on each bow.

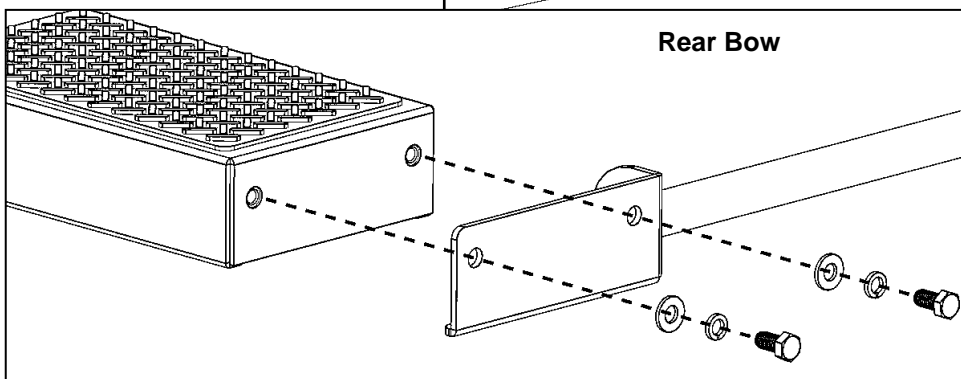
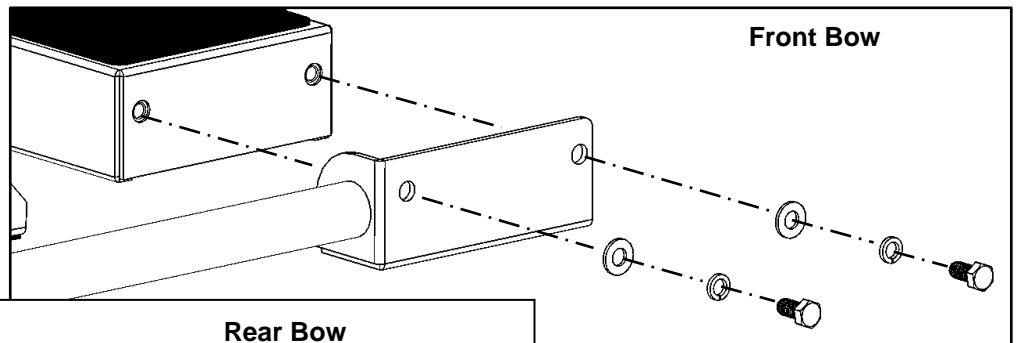
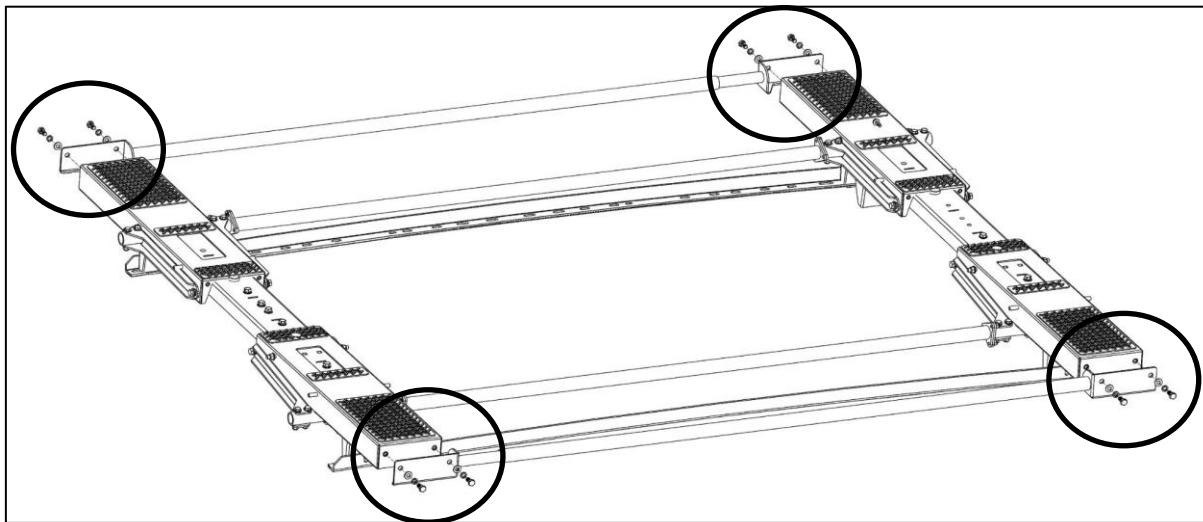
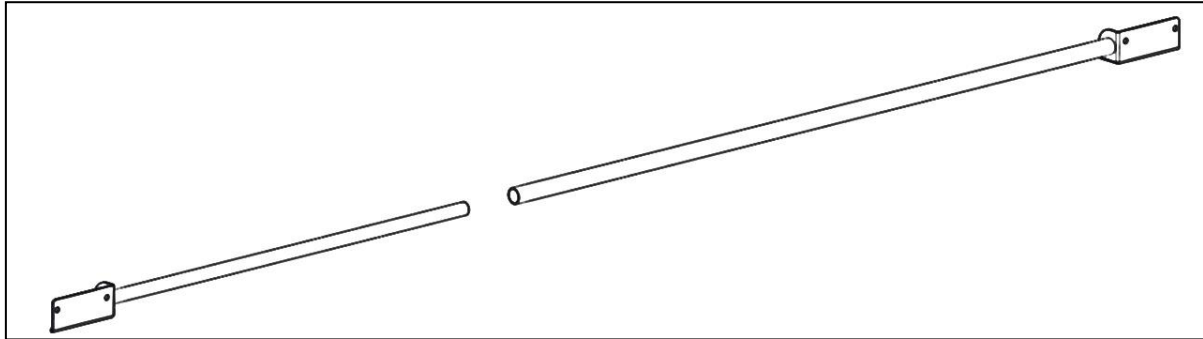

- TIGHTEN.
- Repeat on opposite side of rack.

Step 7 – Determine Ladder Stop Locations

NOTE: On side of each bow, there are two positions available for mounting the ladder stops and ladder hooks based on the size and type of ladder. Ladder stops may be installed either further inboard or further outboard, depending on the ladder to be used. It is best to determine the size and type of ladder prior to installing the ladder stops and ladder hooks. The following are examples of a typical 8 foot stepladder and 10 foot extension ladder mounted on the drop down ladder rack.

The following are the two positions available on each bow.

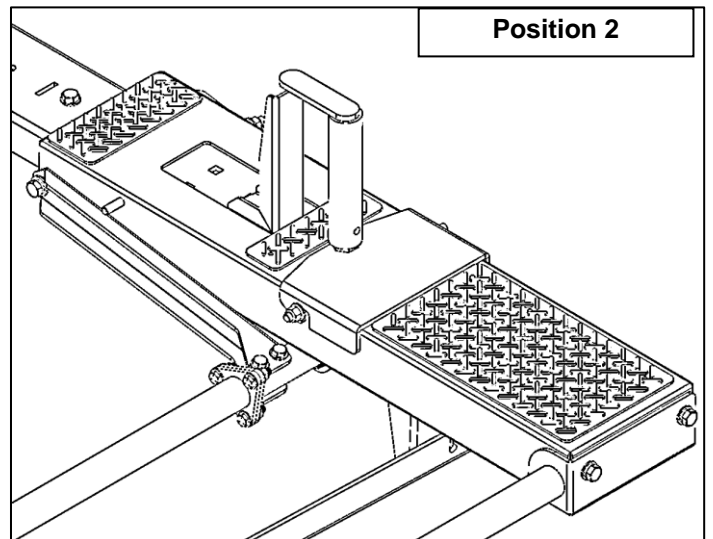
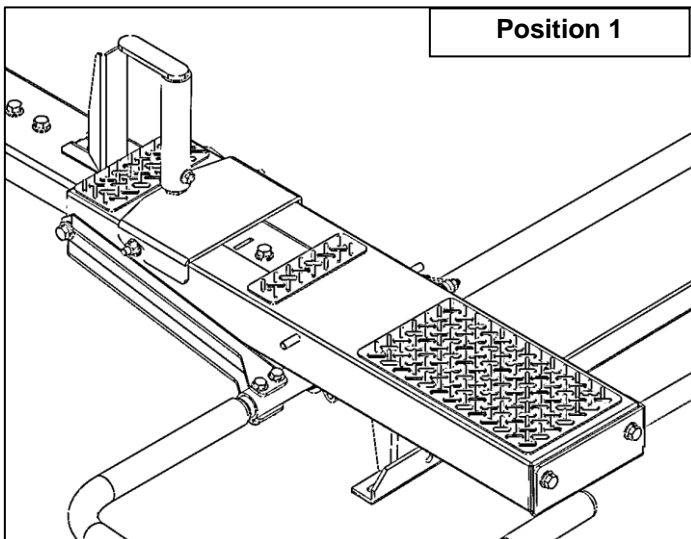
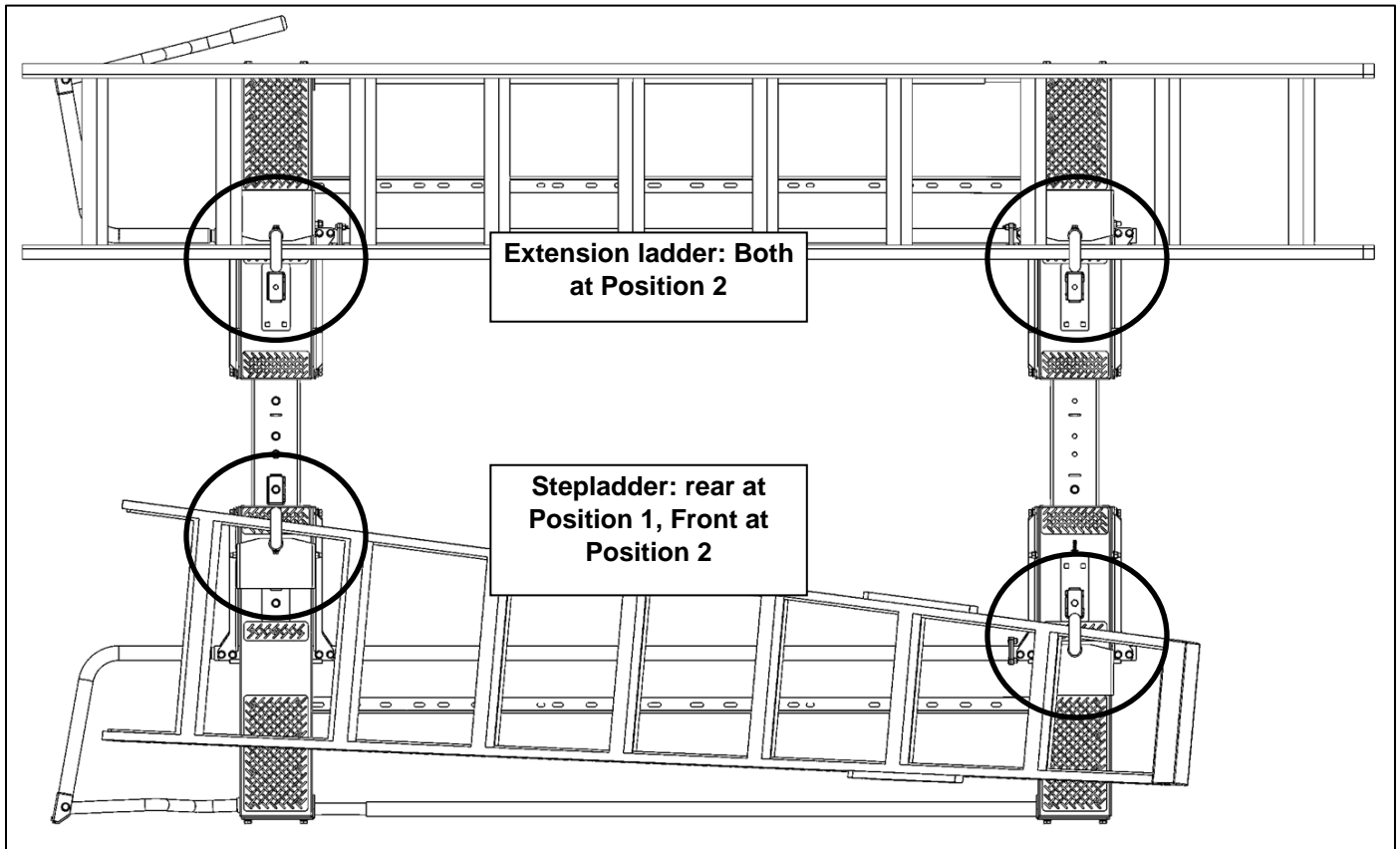

Position 1

- For each ladder hook in this position, place the ladder hook base around the threaded studs in the desired location and tighten.
- For the rear bow, remove the existing 3/8" x 1" hex head bolt, a 3/8" split lock washer and a 3/8" flat washer. For the front bow, use a 3/8" x 1" hex head bolt, 3/8" flat washers, and 3/8" lock nut from the hardware kit.
- Position the ladder stop near the ladder hook base, as shown, with the flange on ladder stop aligned with the slot in the bow.
- Install ladder stop and tighten.

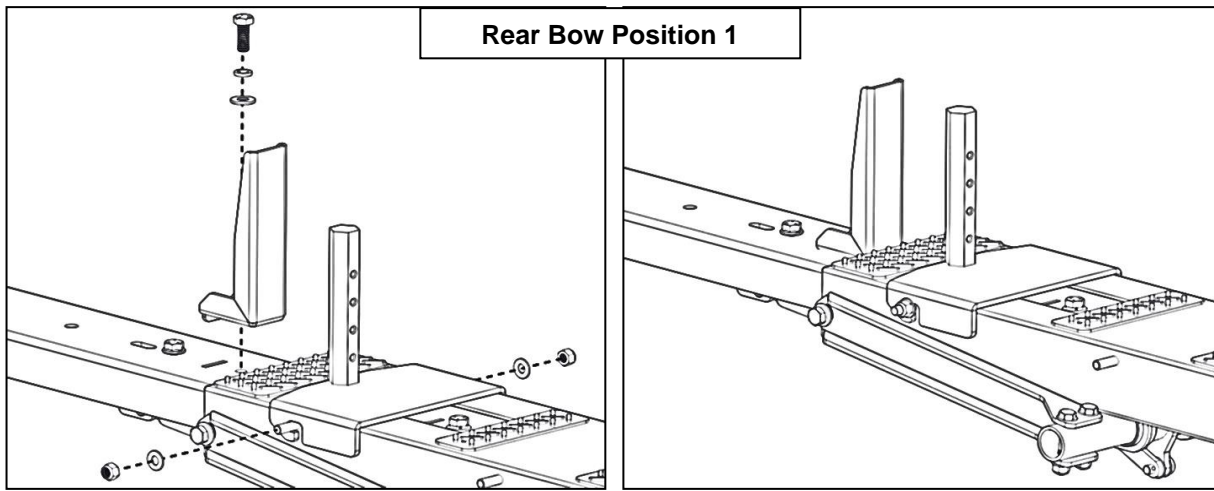

Position 2

- For each ladder hook in this position, place the ladder hook base around the threaded studs in the desired location and tighten.
- Position the ladder stop near the ladder hook base, as shown, with the flange on ladder stop aligned with the slot in the bow.
- Remove the existing 3/8" x 1" hex head bolt, a 3/8" split lock washer and a 3/8" flat washer.
- Bolt the ladder stop in place using the removed hardware.
- Repeat on opposite side of rack as required for the ladder type chosen for that side.

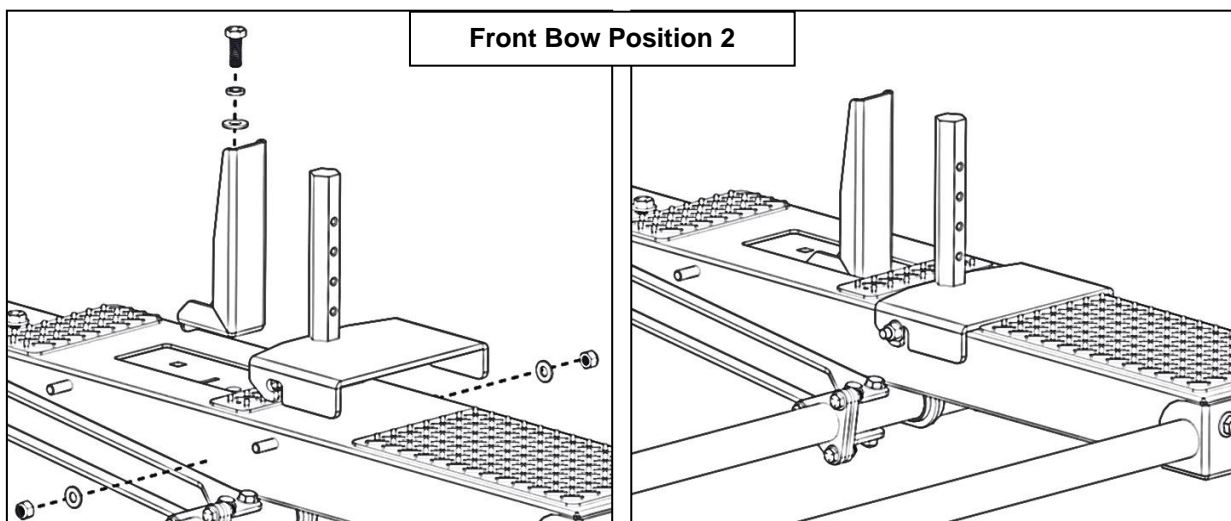

Step 8 – Install Latches

- Rotate rear pan assembly out of the way to expose the end of the cross member.
- Using 5/16" x 1" carriage bolts, 5/16" flat washers and 5/16" lock nuts, bolt through the middle set of square holes as shown.
- TIGHTEN.
- Repeat on opposite side of the rear bow.

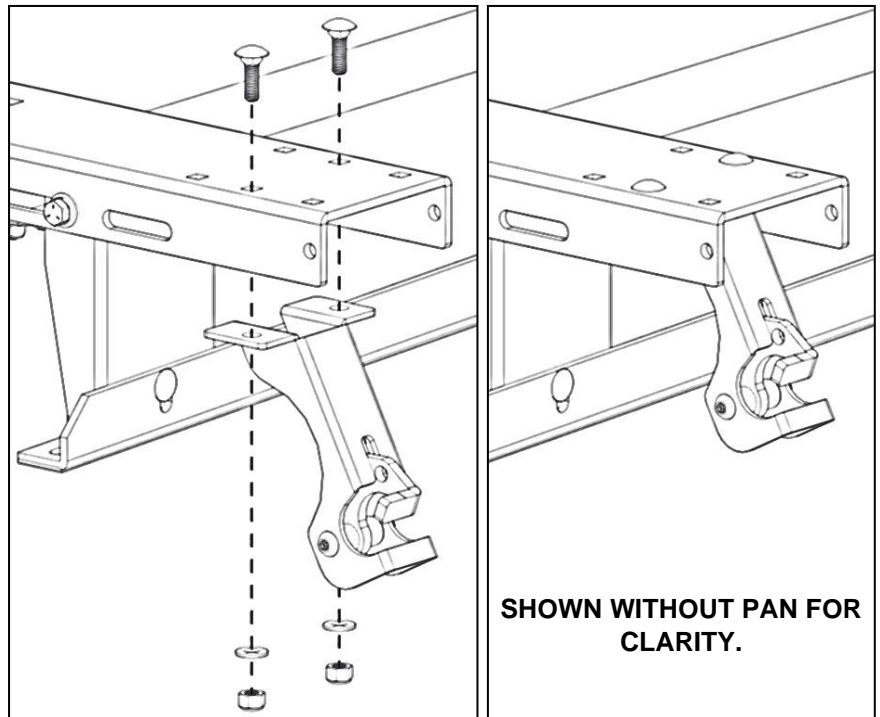

Step 9 – Install Handle

- Remove the 5/16" flanged head screws, 5/16" washers, and 5/16" lock nuts from rear bow as shown.
- Apply sealant to swaged end of handle.
- Use removed hardware to bolt handle into position.
- TIGHTEN.

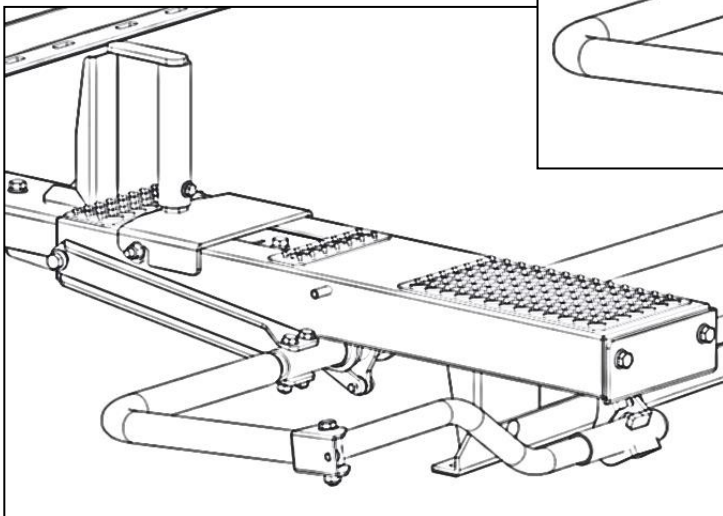
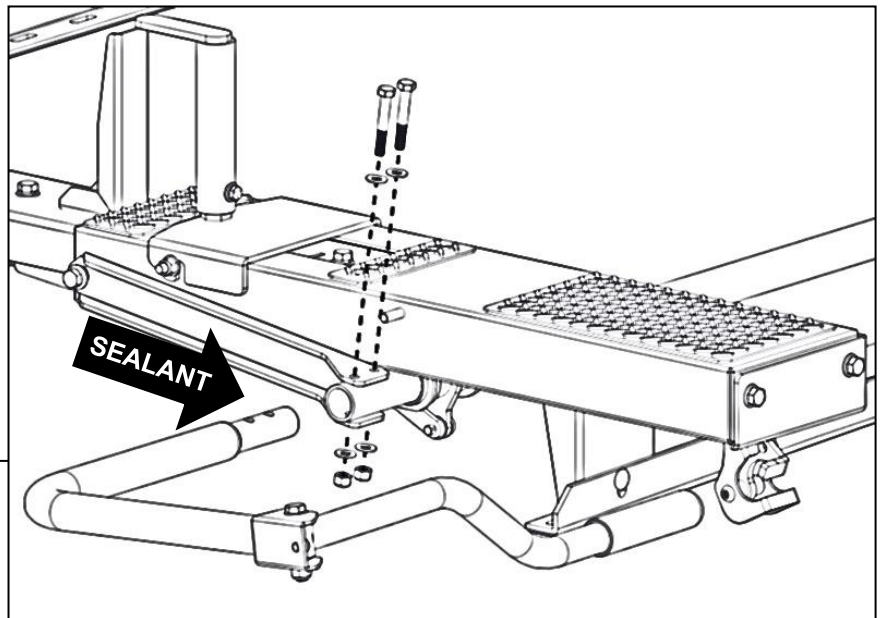

- Repeat on opposite side of rear bow.

Step 10 – Assemble Ladder Hooks

Note: Before use the ladder hook must be adjusted to an appropriate height for the ladder that will be used. The height of the hook needs to be at least 1/4" greater than the ladder. The ladder should fit loosely on the hook, not snug.

- Measure the thickness of the ladder that will be used and determine the appropriate mounting hole on the ladder hook weldment that will allow for a loose fit.
- **Be sure the height of the hook is AT LEAST 1/4" GREATER THAN the thickness of your ladder.**
- If you are unsure of the thickness of the ladder that will be used, set the height of the hook to the highest setting (9 inches) and adjust it later.

NOTE: Roof height clearance is affected by the hook mounting location used. Please verify and be aware of the total height of the vehicle with rack installed.

- Using a 1/4" x 1" hex head, a 1/4" lock washer and a 1/4" flat washer, bolt ladder hook assembly to ladder hook weldment using the previously determined mounting location.
- Tighten.

SQUARE THE RACK.

GO BACK AND ENSURE ALL HARDWARE IS TIGHT.

ASSEMBLY AND INSTALLATION ARE COMPLETE.

