

Holman

Instruction Guide 4A98L

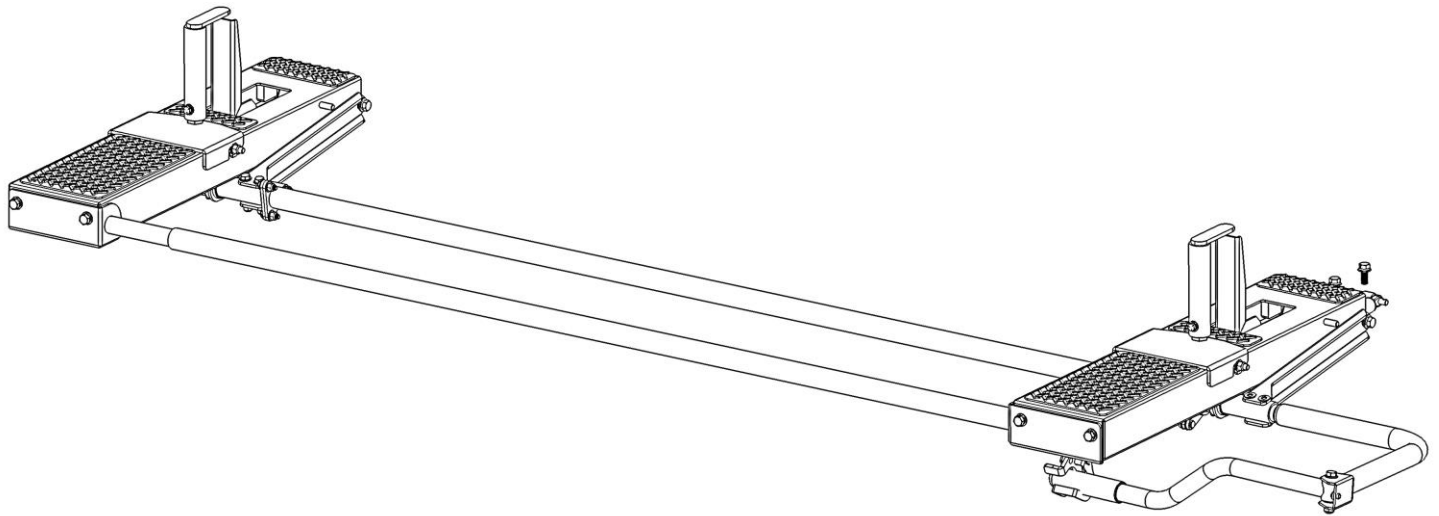

Holman
Rancho Cordova, CA 95742
800-343-7486
InstallationSupport@holman.com

PLEASE READ ALL INSTRUCTIONS AND WARNINGS PRIOR TO ASSEMBLING, INSTALLING, AND USING THIS PRODUCT.

Warning



Always check for wires, fuel tanks and lines, brake lines and other important vehicle functionality items prior to drilling and installing all products.



DO NOT EXCEED MANUFACTURERS WEIGHT CAPACITY FOR ROOF.

Tools Needed

1/2" Wrench and Socket	3/8" Wrench and Socket
9/16" Wrench and Socket	7/16" Wrench and Socket

Table of Contents

Parts 2

Hardware 3

Step 1 – Remove End Stops 5

Step 2 – Install Latch Assembly 5

Step 3 – Install Rear Bow Damper Mechanism 6

Step 4 – Install Dampers 7

Step 5 – Install Rear Wheels 7

Step 6 – Install Rear Pan 8

Step 7 – Install Front Pan Mechanism 9

Step 8 – Install Front Wheels 10

Step 9 – Remove Bolts 10

Step 10 – Install Front Pan 11

Step 11 – Attach Torque Tube 11

Step 12 – Install End Tube 12

Step 13 – Install Ladder Stops 13

Step 14 – Assemble Ladder Hooks 14



Step 15 – Install Ladder Hooks 14

Step 16 – Install Handle 15

Before You Begin

- Read all instructions prior to assembling or installing any Holman product.
- **Always locate your installation locations prior to performing any work.**
- **Have rack already installed on vehicle. This product is a driver side drop down addition.**

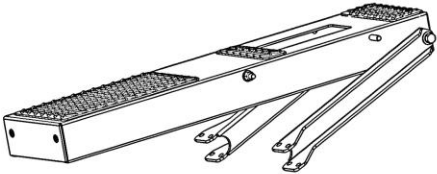
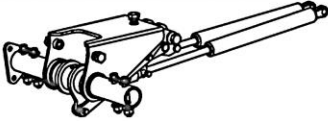
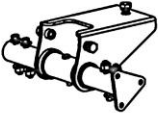
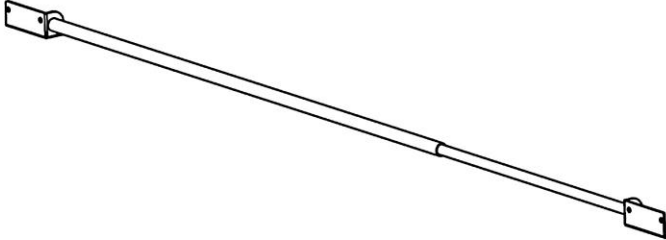
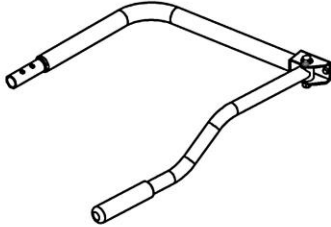
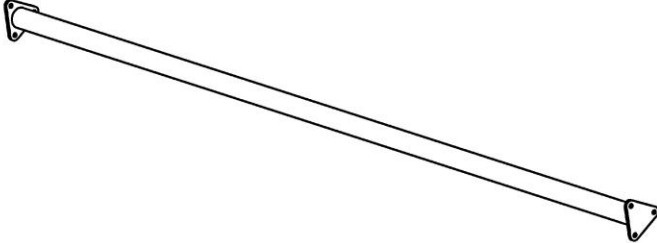

Parts

ITEM NO.		PART NUMBER	DESCRIPTION	QTY.
A		4A93L-10	ASSEMBLY, BOW, PAN, LADDER RACK, ALUMINUM	2
B		4A98L-11	MECHANISM, ASM, WITH DAMPERS	1
C		4A93L-12	MECHANISM, ASM	1
D		4A93L-7	END TUBE, ASM	1
E		4A98L-40	DS HANDLE, ASM	1
F		4A93L-50	WELDMENT, TORQUE TUBE, STEEL, 71.5" SPACING, LOW ROOF DROP DOWN	1
G		4A92L-44-R1	LATCH ASM	1

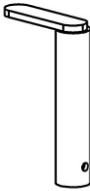
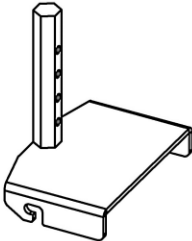
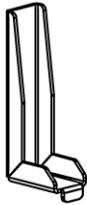

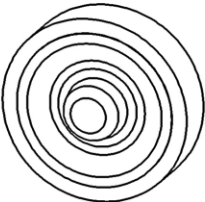
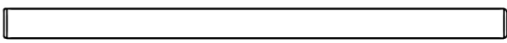
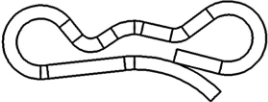
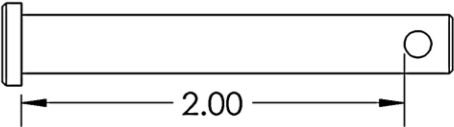

Parts (Continued)

NO.		PART NUMBER	DESCRIPTION	QTY.
H		4A900-35	LADDER HOOK ASM	2
J		4A900-36	LADDER HOOK BASE ASM	2
K		4A900-30-004-R3	LADDER STOP	2
		18-4A98L	HARDWARE	1

Hardware

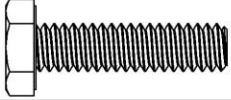
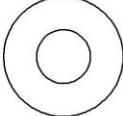
ITEM	HARDWARE TO SCALE	PART NUMBER	DESCRIPTION	QTY.
1			1"X5/16" RUBBER BUMPER	2
2			WHEEL, POLYURETHANE, 2 1/4" X 9/16"	4
3			AXLE	2
4		92418A225	BOW TIE COTTER PIN	1
5		0156744	PIN, CLEVIS, 5/16 X 2"	1
6			SPACER, PLASTIC, 5/16" ID, .72 L	1

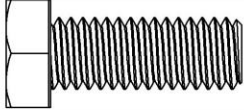
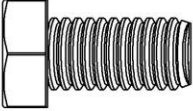
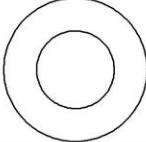
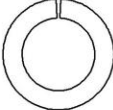
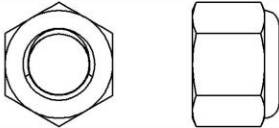
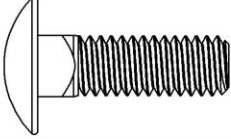
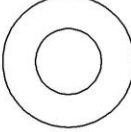
Hardware (Continued)

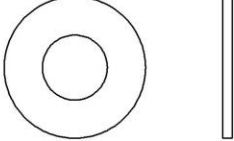
ITEM	HARDWARE TO SCALE	PART NUMBER	DESCRIPTION	QTY.
7		13005	1/4-20 X 1" HEX HEAD BOLT	8
8		33078	1/4" FLAT WASHER	14
9		1133618	1/4"-20 LOCK WASHER	2
10		37018	1/4-20 LOCK NUT	6
11		70105	3/8"-16 X 1 HEX HEAD BOLT	1
12		11241196	3/8-16 X 3/4" HEX HEAD BOLT	4
13		1133082	3/8" WASHER	6
14		1133622	3/8" LOCK WASHER	4
15		0169791	3/8"-16 LOCK NUT	1
16		21811	5/16"-18 X 1" CARRIAGE BOLT	2
17		11545144	5/16" FLAT WASHER	2
18		0169777	5/16"-18 LOCK NUT	2
19			.05X.34X.75 NYLON WASHER	6
20		SEALANT - 60ml	SEALANT	1

DO NOT EXCEED MANUFACTURERS WEIGHT CAPACITY FOR ROOF.

Step 1 – Remove End Stops

- If installed, remove end stops on the drivers side, at the end of each bow.
- Repeat for both bows.

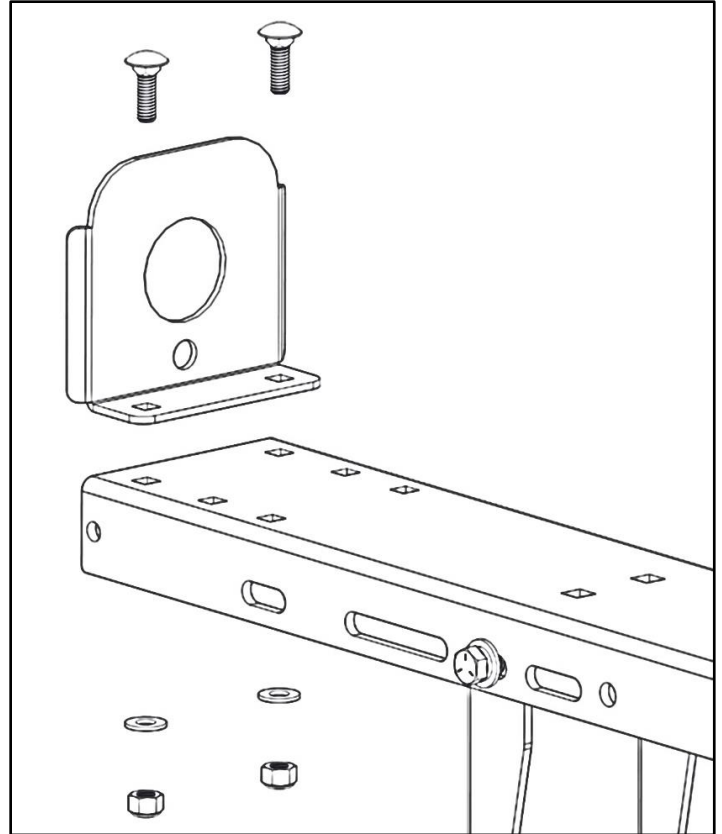

Step 2 – Install Latch Assembly

- At the open end of the rear bow, mount latch assembly in the squares shown.
- Use the 2nd set of square holes from the end of the bow.
- Mount using two 5/16" x 1" carriage bolts, two 5/16" flat washers and two 5/16" lock nuts.

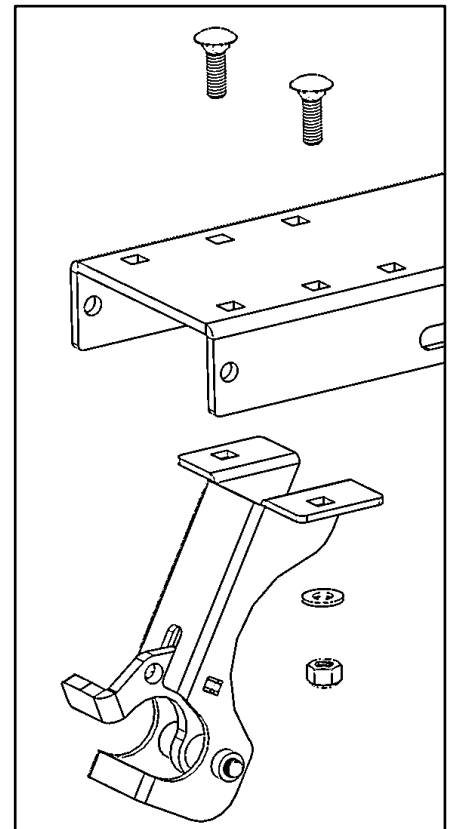
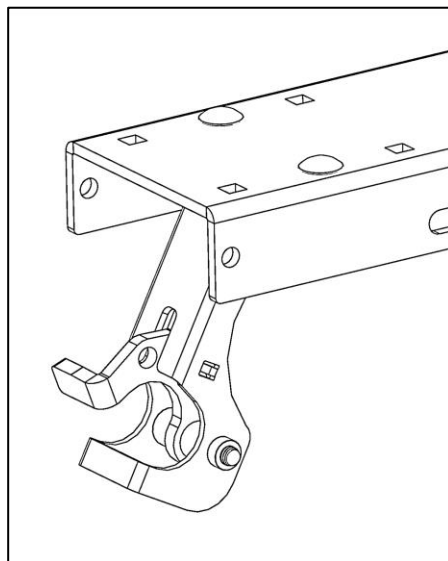

Step 3 – Install Rear Bow Damper Mechanism

- Mount damper mechanism to the underside of the rear bow in the location shown.
- Use the existing hardware found in the damper mechanism to mount.
- While using the 3/8" x 4-1/2" hex head bolt. Be sure to not loose the nylon washers. The nylon washers go on the inside of the bow.
- Snug tighten, but allow movement.

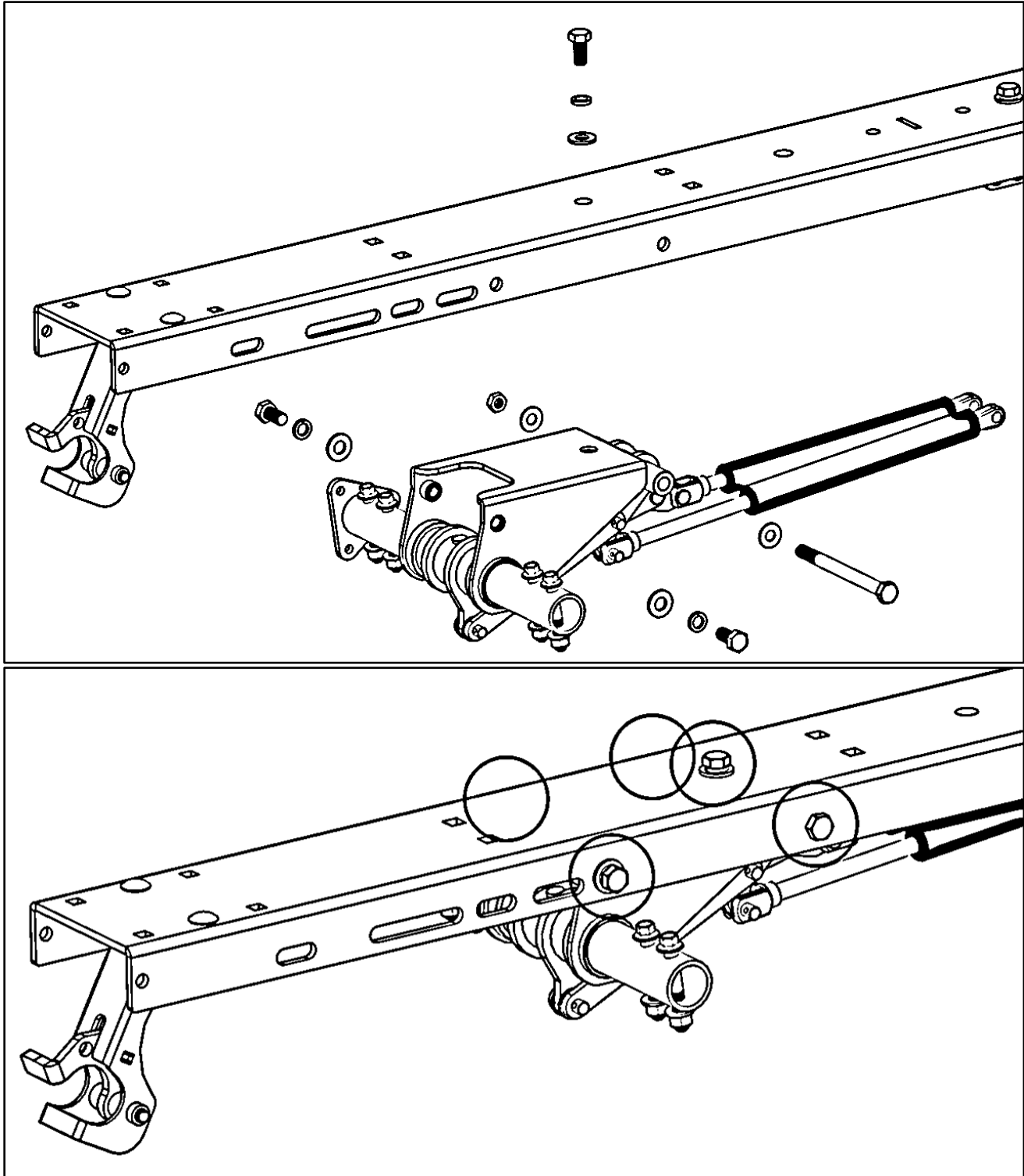

Step 4 – Install Dampers

- Install dampers underneath the rear bow to the existing damper mount using clevis pin, two nylon washers, a plastic spacer, and cotter pin. . The plastic spacer goes in between two dampers. The nylon washers go between the dampers and the inside of the damper mount block. **Be sure cotter pin is correctly fastened.**
- In some situations, one may need to wait until handle assembly is installed to attach both ends of both dampers. This is so you can use the handle to help compress the damper.

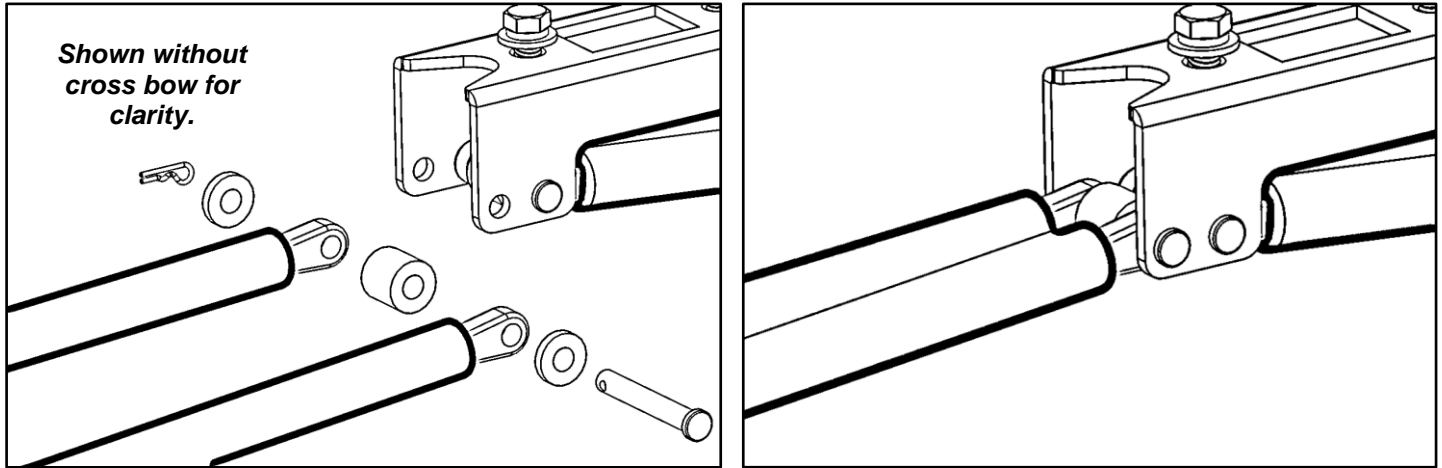

Step 5 – Install Rear Wheels

- Install rear wheels.
- Slide wheel axle in the end of the rear bow.
- Place nylon washer in between the bow and the wheel.
- Place a wheel on each end of the axle.

Note: While placing the pan in the next steps, be sure the wheel caps DO NOT come off.

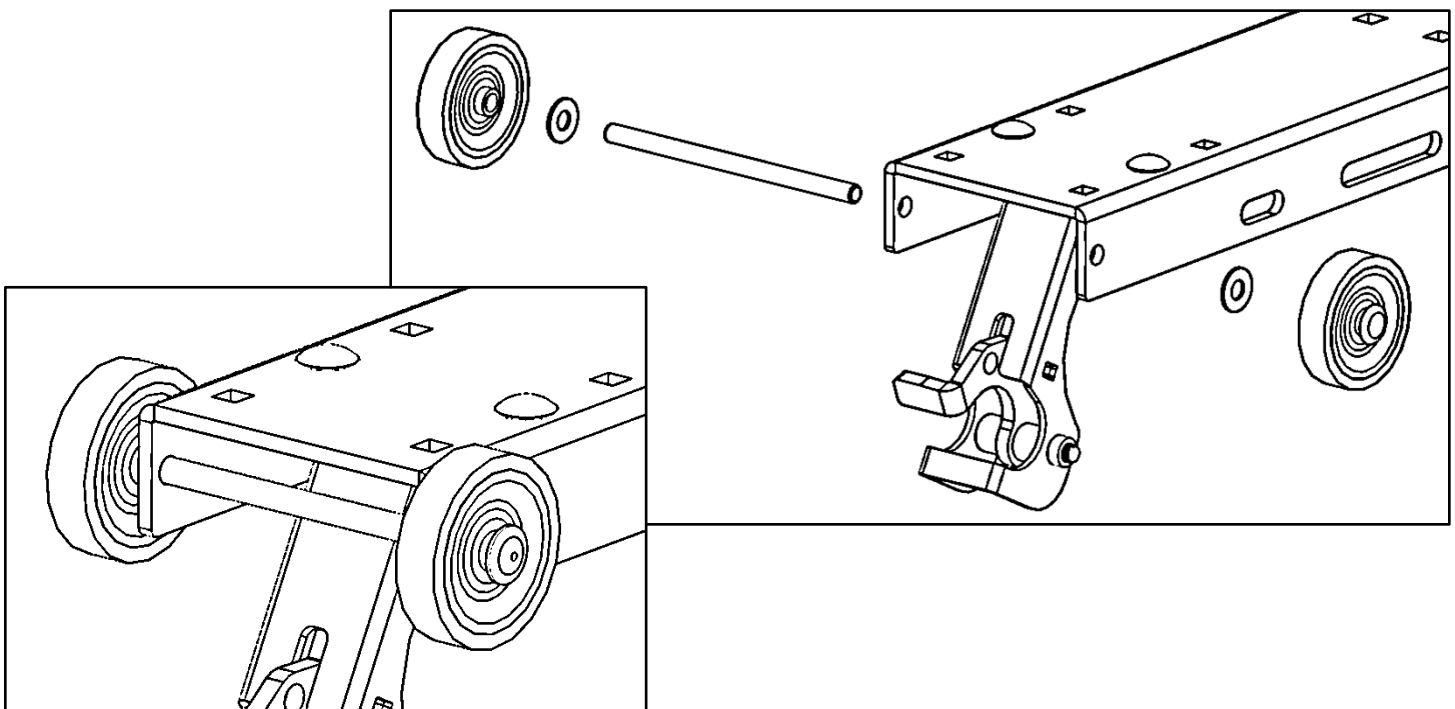

Step 6 – Install Rear Pan

- Remove hardware from the installed damper mechanism from step 3.

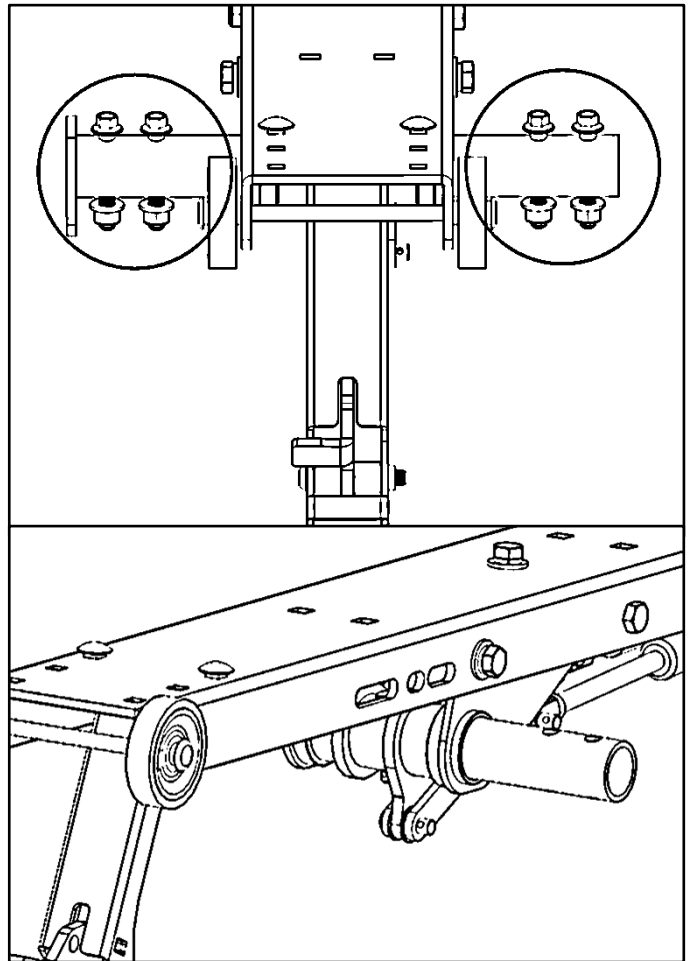
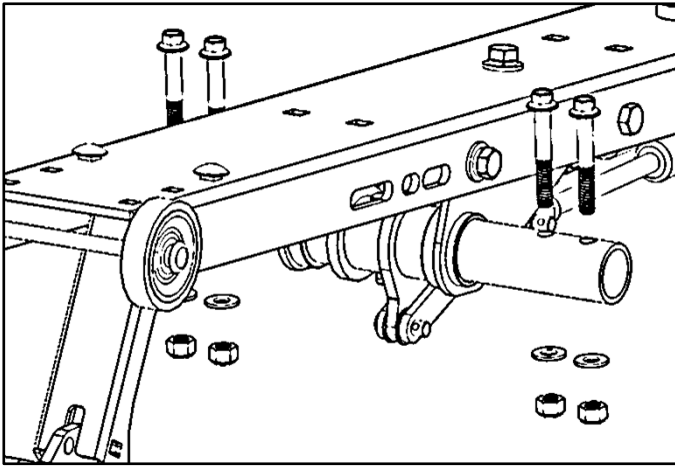

- Place rear pan on top of wheels and bow. **Be sure the wheel caps DID NOT come off.**
- Align the arms from the pan with the holes in the damper mechanism where the bolts were previously removed.
- Bolt together using hardware that was removed, only use the front two bolts, leaving the holes on the rear side empty as shown. The empty holes are for the handle installation.
- Snug tighten, but allow movement.

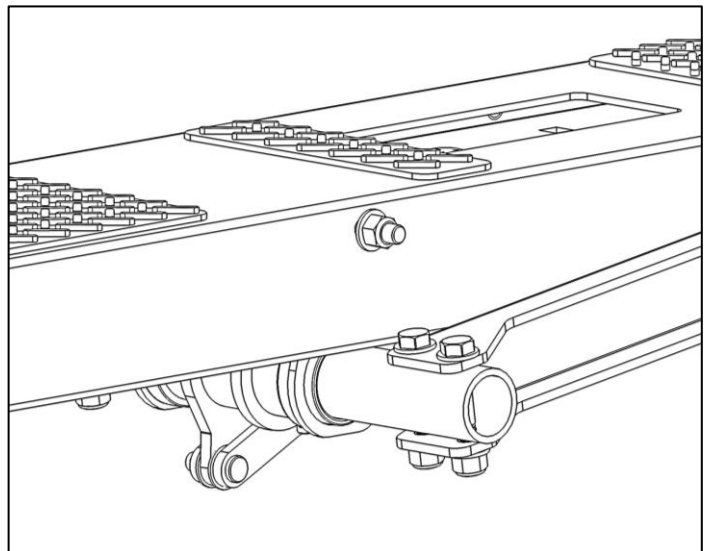
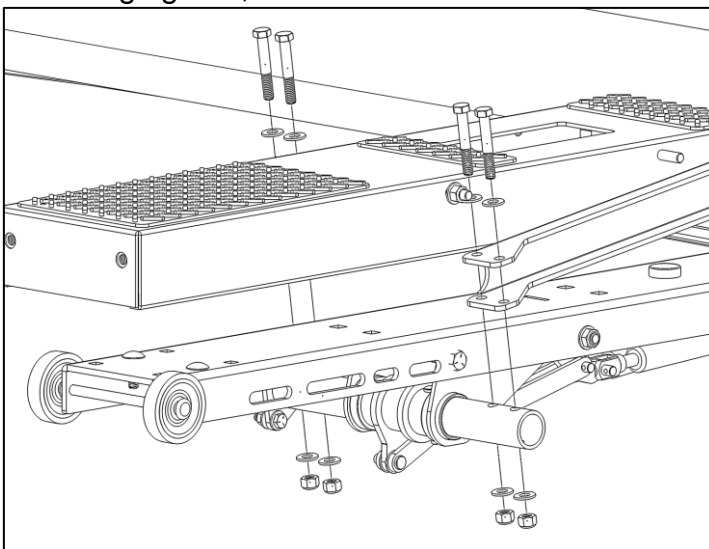

Step 7 – Install Front Pan Mechanism

- Mount the front mechanism to the underside of the front bow in the location shown. **This mechanism DOES NOT have the dampers.**
- Use the existing hardware found in the mechanism to mount.
- Snug tighten, but allow movement.

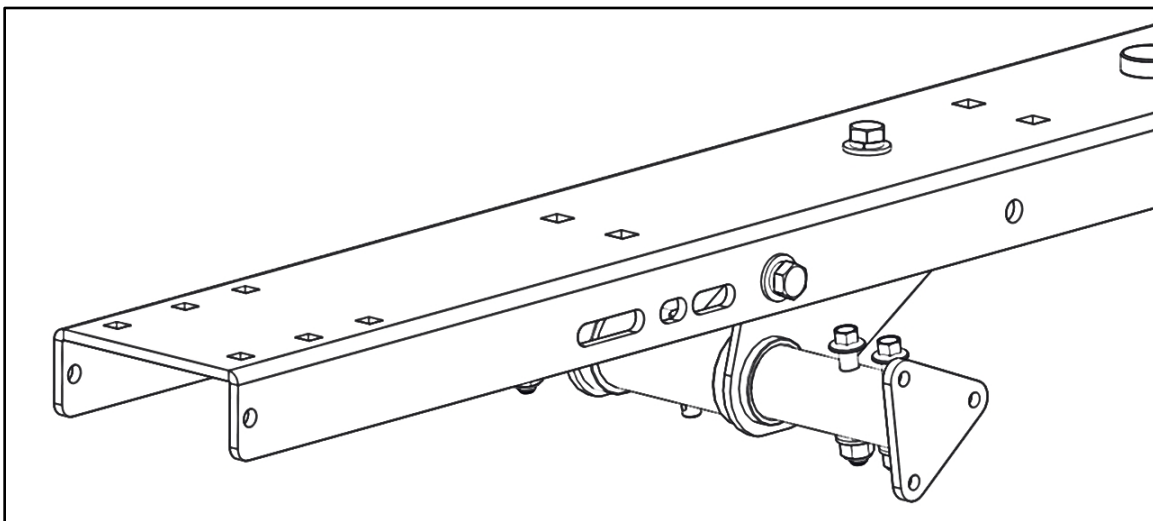
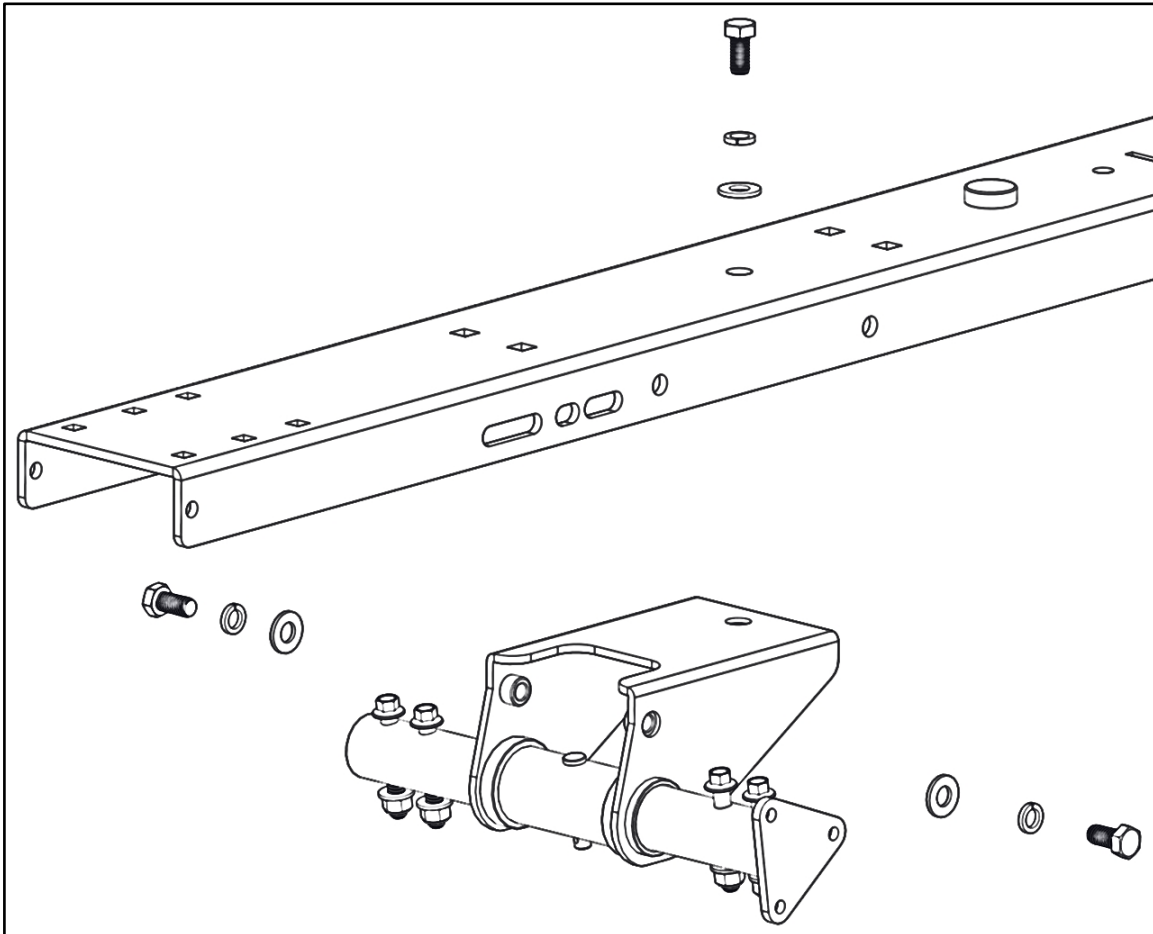

Step 8 – Install Front Wheels

- Install front wheels.
- Slide wheel axle in the end of the front bow.
- Place nylon washer in between the bow and the wheel.
- Place a wheel on each end of the axle.
- Cap the wheel with wheel stopper.
- **While placing the pan on the next step, Be sure the wheel caps DO NOT come off.**

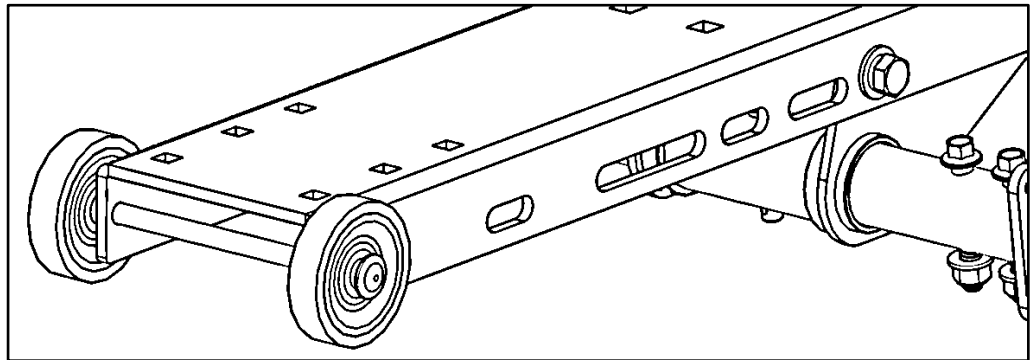
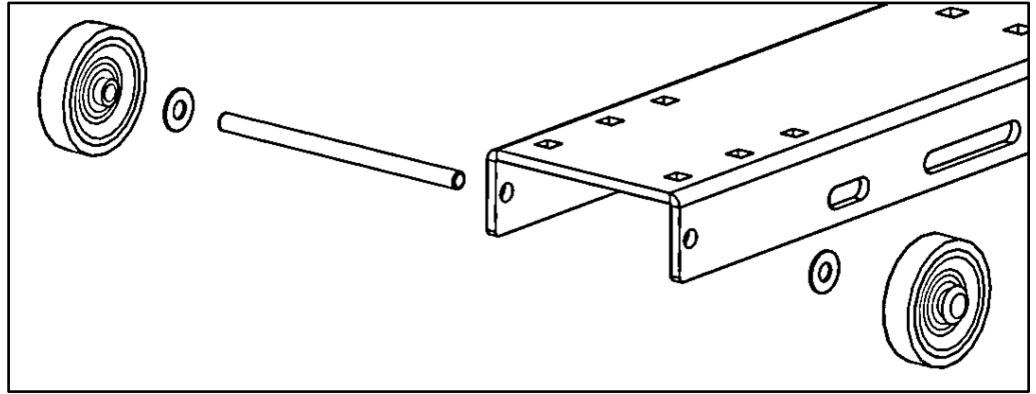

Step 9 – Remove Bolts

- Remove hardware from the previously installed mechanism from step 7.

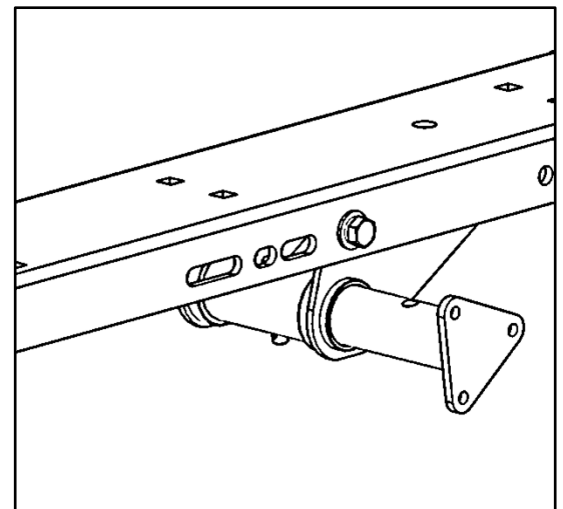
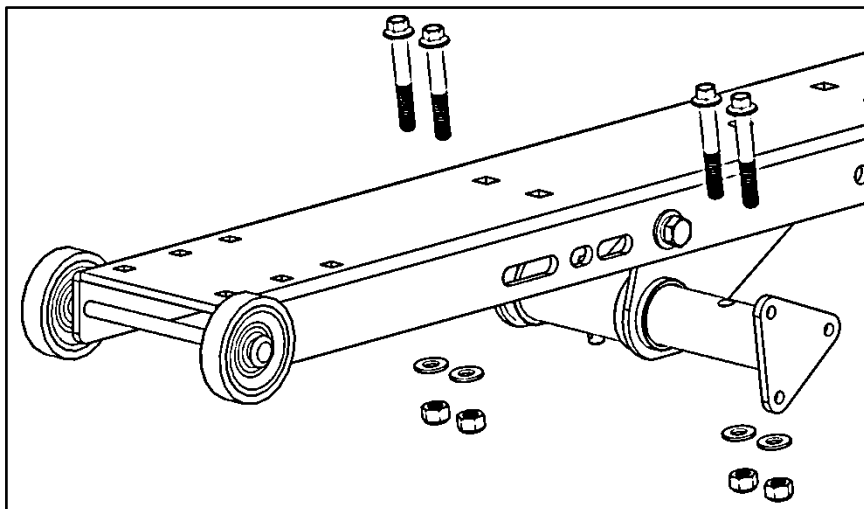
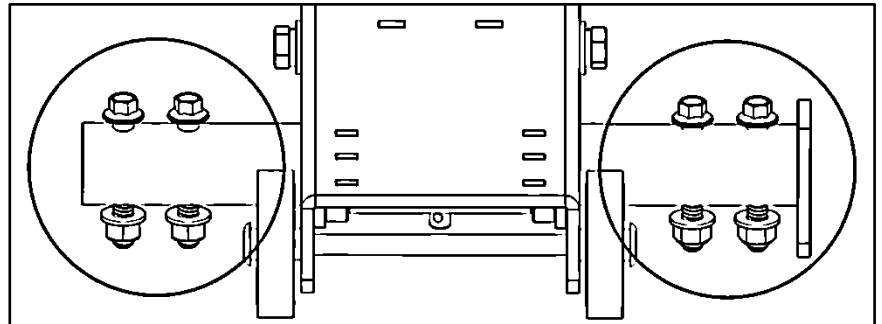

Step 10 – Install Front Pan

- Place front pan on top of wheels and bow. **Be sure the wheel caps DID NOT come off.**
- Align the arms from the pan with the holes from the mechanism where bolts were previously removed.
- Bolt together using hardware that was removed.
- Snug tighten, but allow movement.

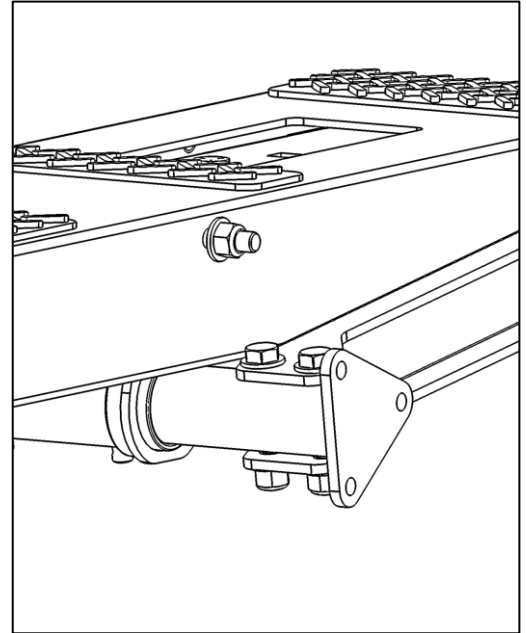
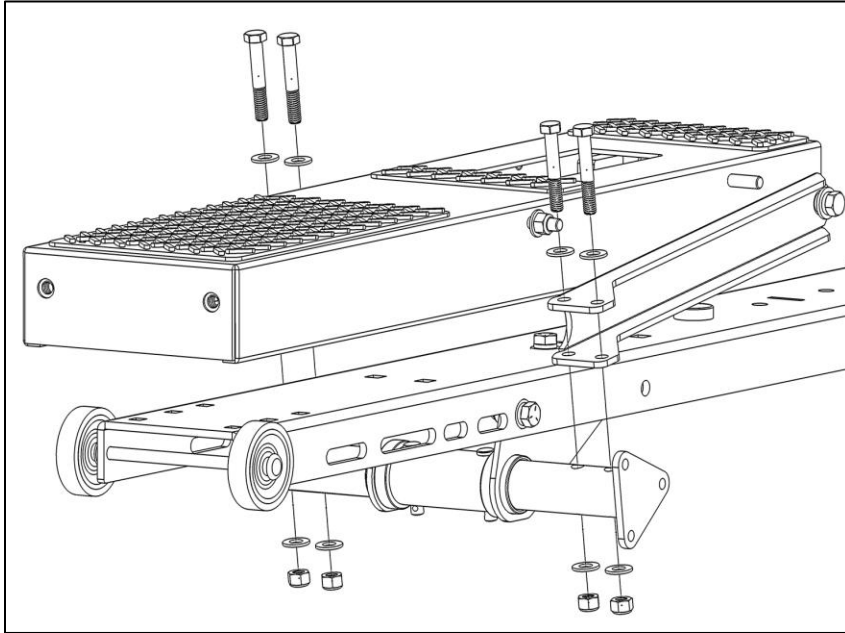

Step 11 – Attach Torque Tube

- Bolt one end of torque tube to front or rear bow using three 1/4" x 1" hex head bolts, six 1/4" flat washers and three 1/4" lock nuts.
- Repeat on opposite end.
- **TIGHTEN.**

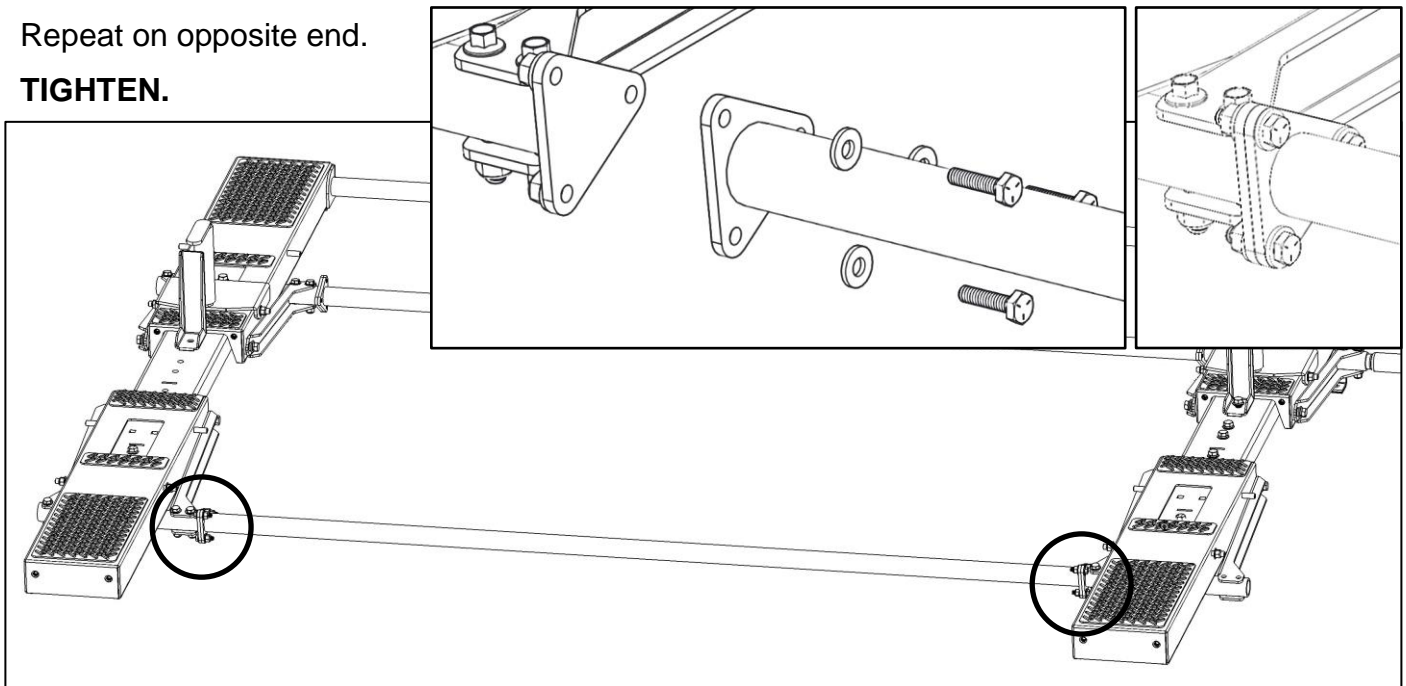

Step 12 – Install End Tube

- Place end tube at the end of each bow.
- Bolt into place using 3/8" x 3/4" hex head, 3/8" lock washer and 3/8" flat washer.
- Repeat at front and rear bow.
- TIGHTEN.

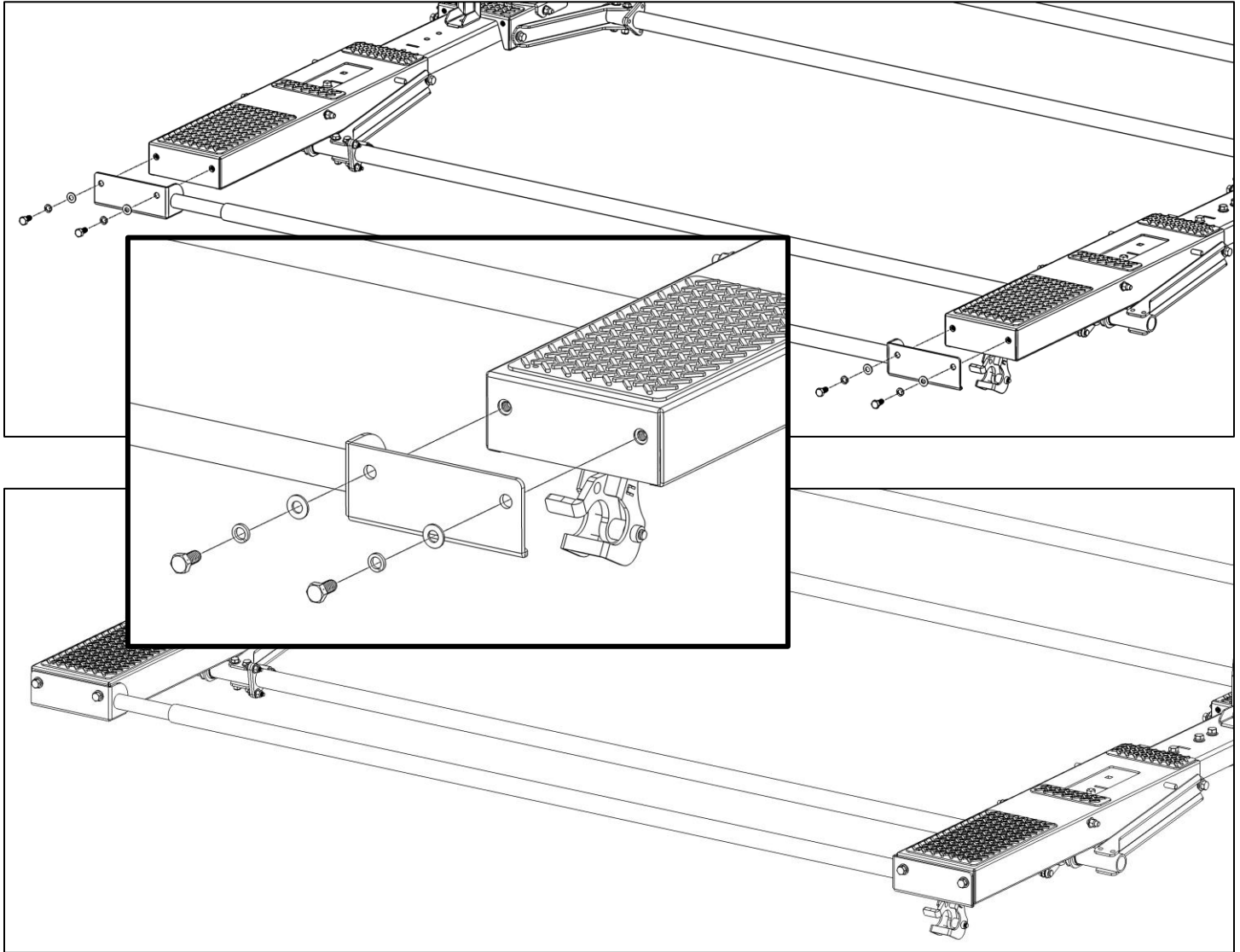

Step 13 – Install Ladder Stops

- Bolt the ladder hook to both bows in the orientation shown.
- **Be sure to have the flange of the hook line up with the slot on the bow.**
- Use the existing hardware in the rear bow to attach the ladder stop to the rear bow.
- Use one 3/8" x 1" hex head, two 3/8" flat washers and one 3/8" lock nut to install on the front bow.
- **TIGHTEN.**

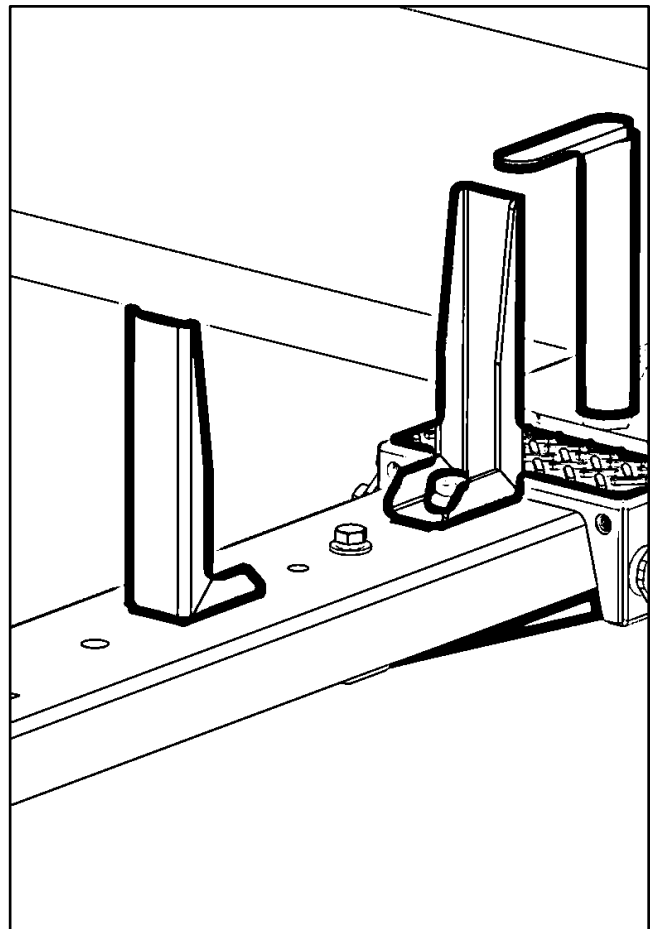
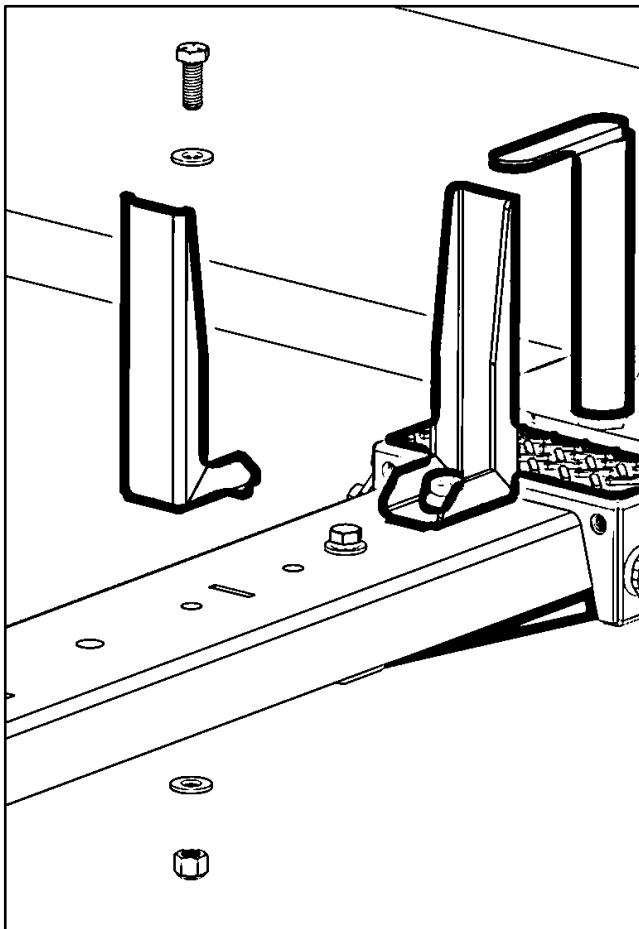
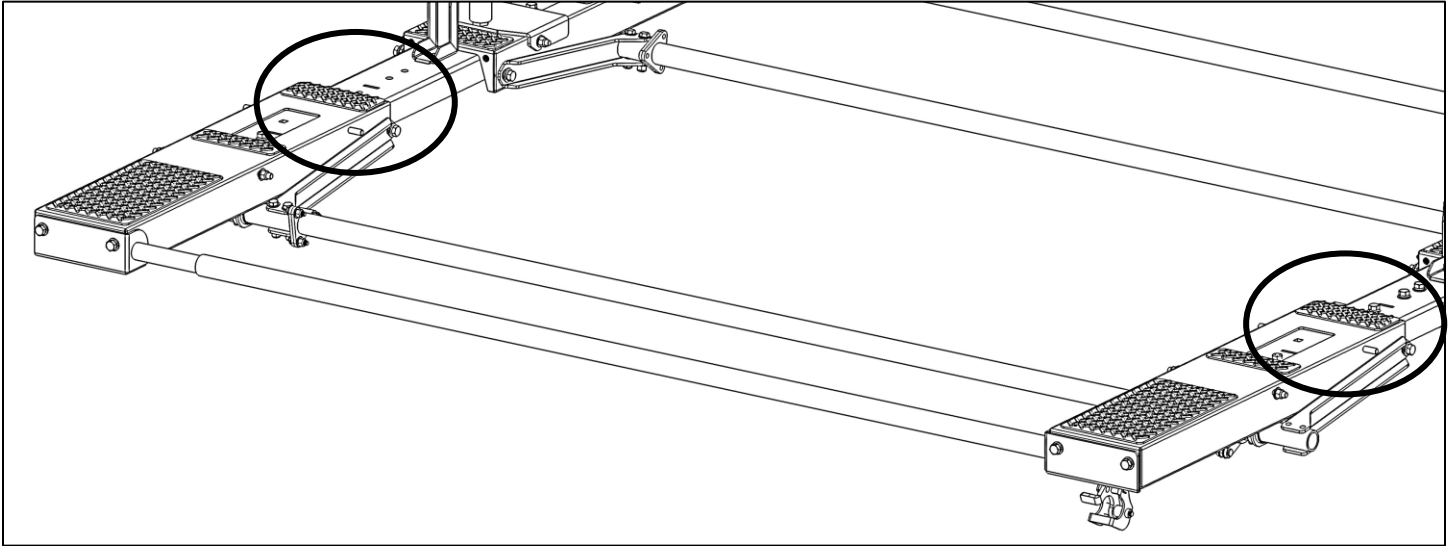

Step 14 – Assemble Ladder Hooks

Note: Before use the ladder hook must be adjusted to an appropriate height for the ladder that will be used. The height of the hook needs to be at least 1/4" greater than the ladder. The ladder should fit loosely on the hook, not snug.

- Measure the thickness of the ladder that will be used and determine the appropriate mounting hole on the ladder hook weldment that will allow for a loose fit.
- **Be sure the height of the hook is AT LEAST 1/4" GREATER THAN the thickness of your ladder.**
- If you are unsure of the thickness of the ladder that will be used, set the height of the hook to the highest setting (9 inches) and adjust it later.

NOTE: Roof height clearance is affected by the hook mounting location used. Please verify and be aware of the total height of the vehicle with rack installed.

- Using a 1/4" x 1" hex head, a 1/4" lock washer and a 1/4" flat washer, bolt ladder hook assembly to ladder hook weldment using the previously determined mounting location.
- Tighten.

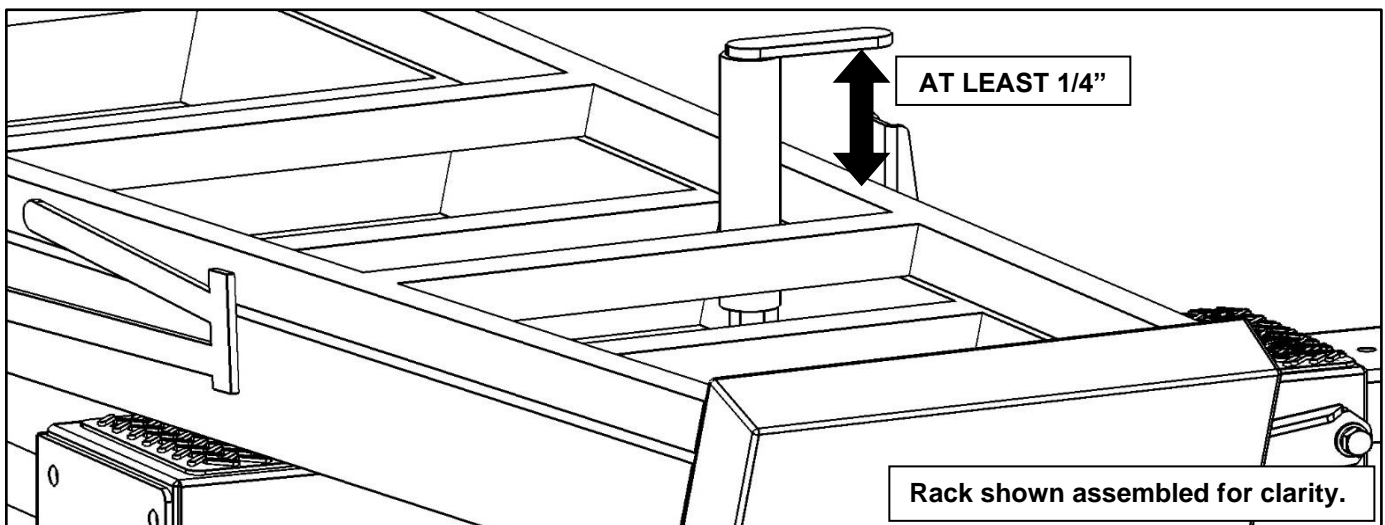
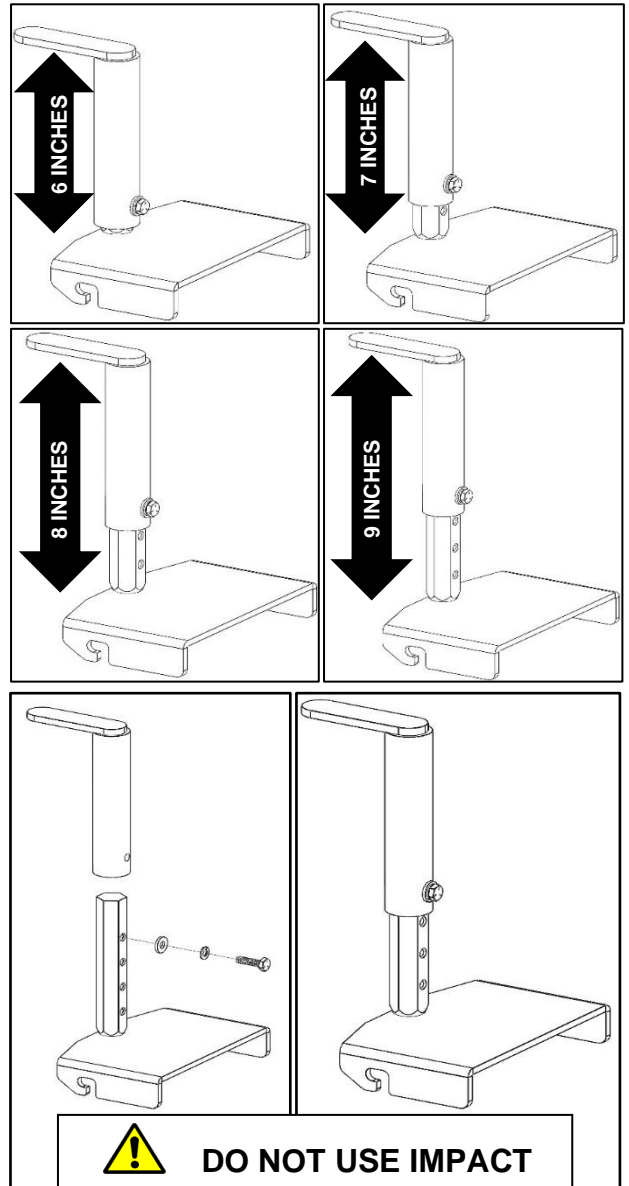

Step 15 – Install Ladder Hooks

- At the location shown, use the hardware on the bows to install the ladder hooks.
- Loosen the nuts and slide the ladder hook into place in the orientation shown. **Be sure the washers are on the outside of the ladder hook.**
- **TIGHTEN.**

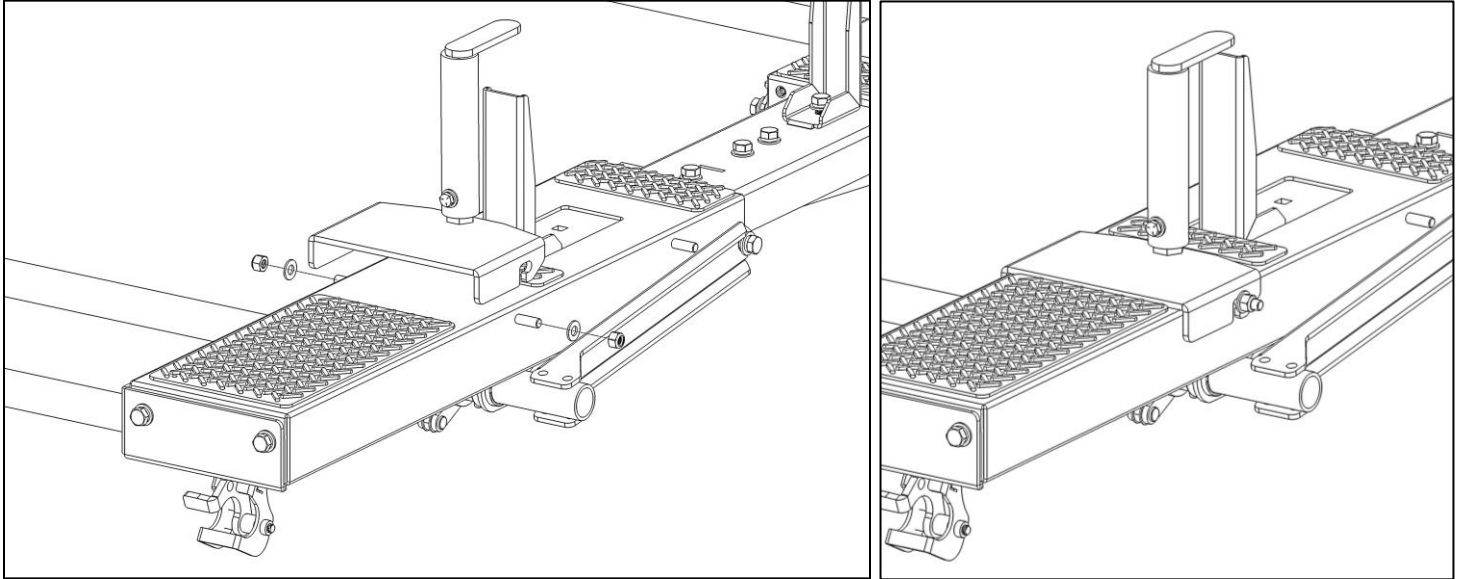

Step 16 – Install Handle

- Using the hardware removed in step 4, insert handle into swage on the rear bow.
- **Be sure to place sealant along swage joint.**
- **TIGHTEN.**

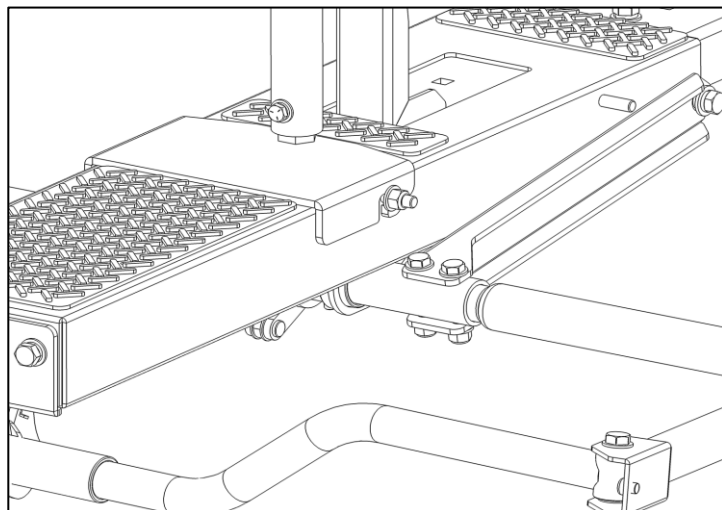
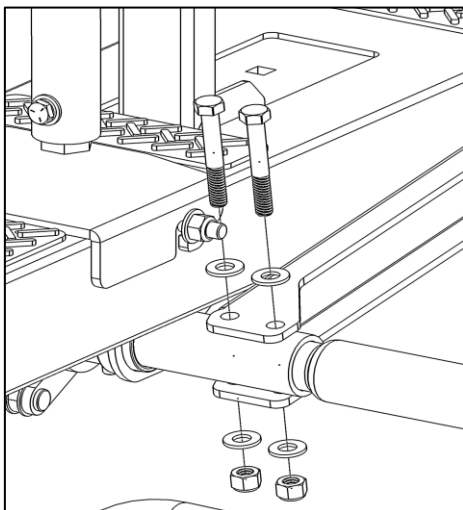
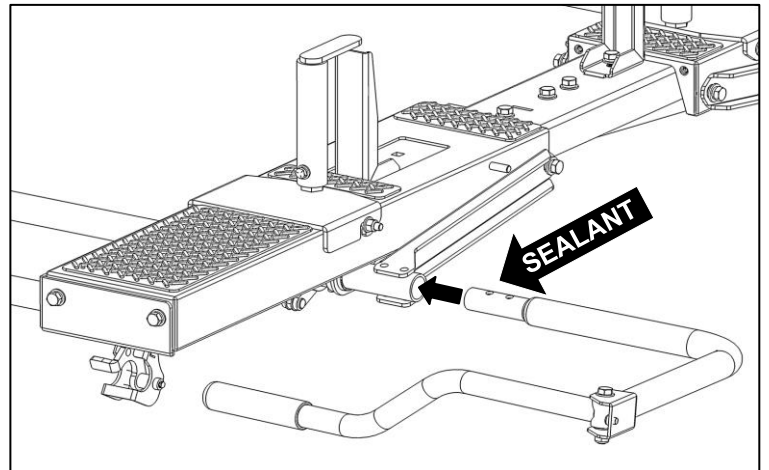

GO BACK AND TIGHTEN ALL HARDWARE.

YOUR INSTALLATION IS NOW COMPLETE.

