

Holman

Installation Guide 70070-70073

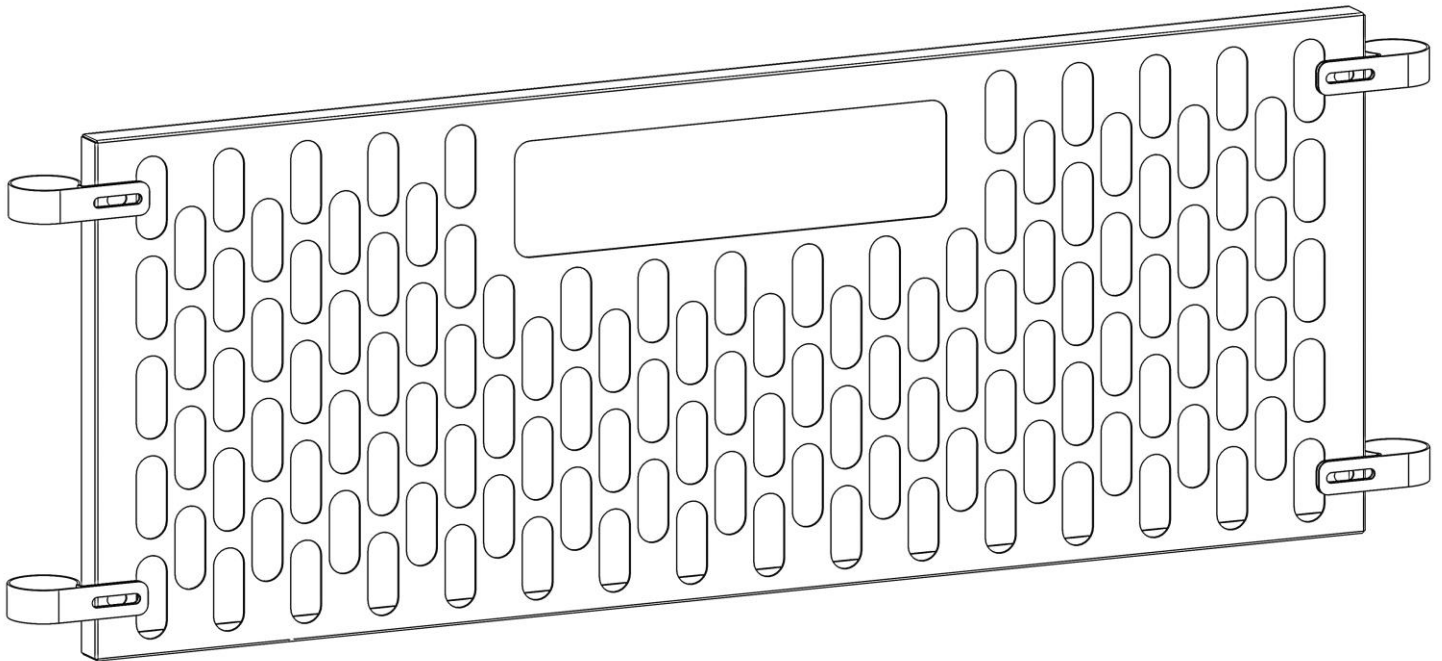

Holman
Rancho Cordova, CA 95742
800-343-7486
InstallationSupport@Holman.com

PLEASE READ ALL INSTRUCTIONS AND WARNINGS PRIOR TO ASSEMBLING, INSTALLING, AND USING THIS PRODUCT.

Warning



**Secure all payloads properly for safe transportation.
DO NOT use window guard as an anchor point for securing loads.**

Tools Needed

1/2" Socket and Wrench	1/2" Box Wrench
------------------------	-----------------

Table of Contents

Before You Begin 1

Hardware 1

Parts List..... 2

Step 1 – Prepare Upper Tube Clamps 2

Step 2 – Prepare Lower Tube Clamps 2

Step 3 – Window Guard Installation 3



Before You Begin

- Read all instructions prior to assembling or installing any Holman product.
- **Always locate your installation locations prior to performing any work.**
- Have rack preassembled before installation of window guard.

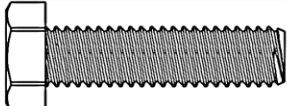
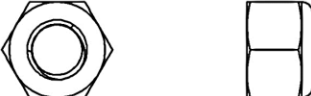
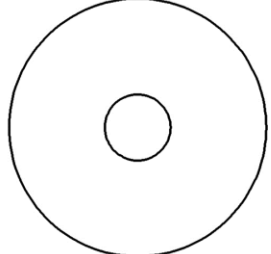
Hardware

ITEM	HARDWARE TO SCALE	PART NUMBER	DESCRIPTION	QTY.
1		11241180	5/16-18 X 1-1/4" HEX HEAD BOLT	4
2		37521	5/16"-18 LOCK NUT	4
3		0189947	5/16" FENDER WASHER	8

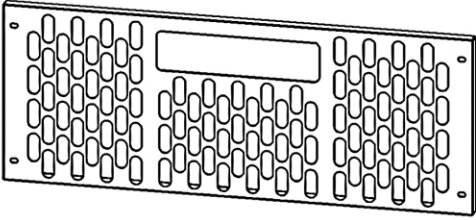
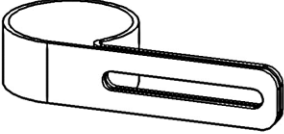
Parts List

NO.	ITEM	PART NUMBER	DESCRIPTION	QTY
1		BLACK: 70070-00-001 WHITE: 70070-00-001W	SERVICE BODY RACK WINDOW GUARD	1
2		BLACK: 12-00191 WHITE: 12-00191W	2" TUBE CLAMP	4
3	 NOT TO SCALE	101805	RUBBER PAD, 1" W X 5" L, 1/32" THICK	4
4	 NOT TO SCALE	12-00191A	RUBBER PAD, 1" W X 4-1/2" L, 1/8" THICK	4
5		18-00160	ECONO WINDOW GUARD HARDWARE KIT	1

Step 1 – Prepare Upper Tube Clamps

This step assumes installation to service body rack with 2" diameter upper leg cups. If mounting top clamp to a smaller diameter tubing, install additional thicker rubber spacers per Step 2 instructions before installing clamp.

- Dry wipe clean inside diameter of two tube clamps.
- Remove plastic backing from a 1/32" thick tape strip.
- Install a tape strip onto inside diameter of a upper tube clamp.
- Repeat for second tube clamp.

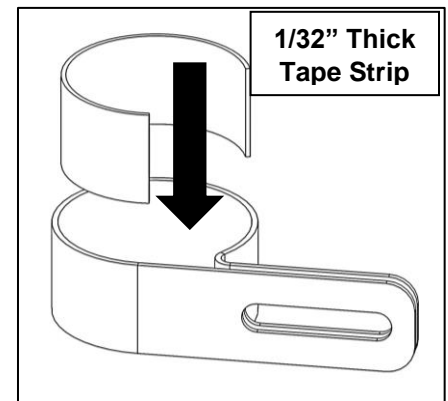

Step 2 – Prepare Lower Tube Clamps

- Dry wipe clean inside diameter of remaining tube clamps.
- Remove plastic backing from a 1/32" thick rubber pad strip.
- Install a rubber pad strip onto inside diameter of tube clamp.
- Dry wipe clean inside diameter of rubber pad strip.
- Remove plastic backing from a 1/8" thick rubber pad strip.
- Install strip onto inside diameter of previously installed 1/32" thick rubber pad strip.
- Repeat for last tube clamp.

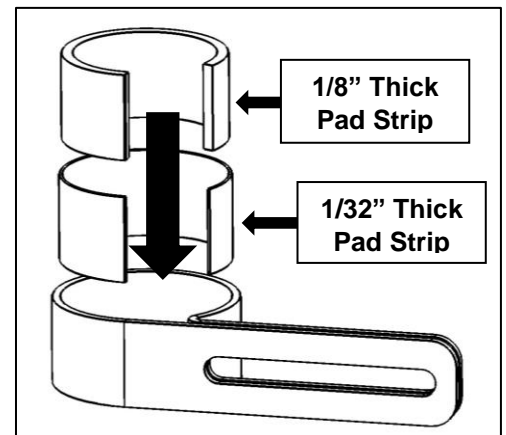

Step 3 – Window Guard Installation

- Determine installation position and take note of approximate location of holes in top and bottom of window guard.
- Squeeze one tube clamp around the top of each of the front legs, at about the position of the hole noted above, with flat end of flange away from the cab.
- Using a 5/16" x 1-1/4" hex bolt and a 5/16" fender washer, bolt through the top tube clamp, then the window guard, and then secure together with another 5/16" fender washer and a 5/16" nut.
- Repeat for opposite side.

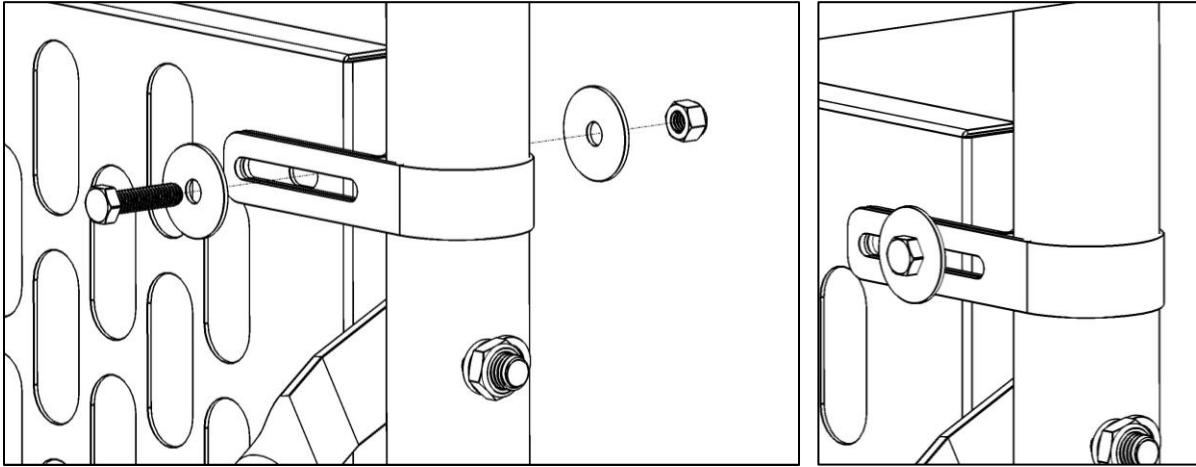

- Repeat for lower tube clamps.

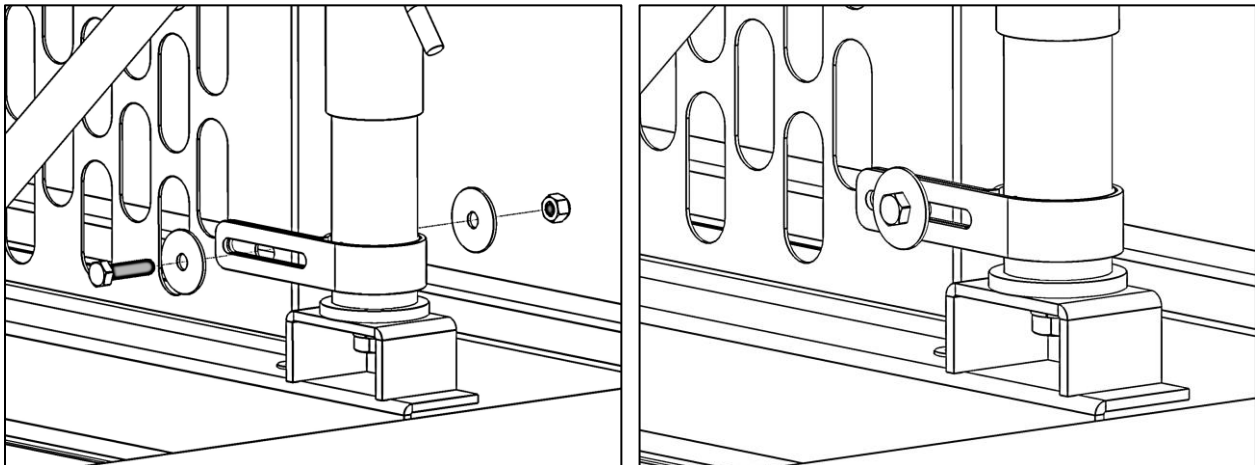

GO BACK AND TIGHTEN ALL HARDWARE.

INSTALLATION IS COMPLETE.