

# Holman

---

## Instruction Guide 80160

---

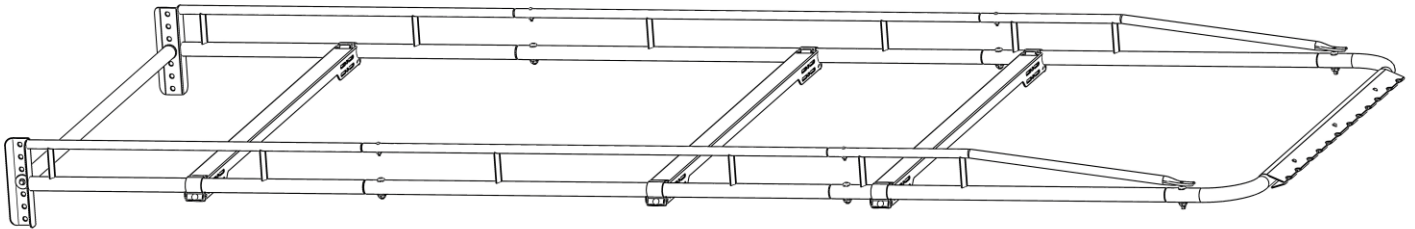

---

Holman  
Rancho Cordova, CA 95742  
800-343-7486

[InstallationSupport@Holman.com](mailto:InstallationSupport@Holman.com)

**PLEASE READ ALL INSTRUCTIONS AND WARNINGS PRIOR TO ASSEMBLING, INSTALLING, AND USING THIS PRODUCT.**

## Warning



**DO NOT EXCEED MANUFACTURERS WEIGHT CAPACITY FOR ROOF.**

## Tools Needed

7/16", 1/2", 9/16" Sockets and Wrench	7/16", 1/2", 9/16" Box Wrenches
#2 Philips Screwdriver	5/32", 5/16" Allen Hex Wrenches





## Table of Contents

Parts .....	2
Hardware (18-80160) .....	3
Hardware (18-8000A-RB) .....	4
Step 1 – Assemble Side Channels.....	5
Step 2 – Attach Wind Deflector to Front Crossbar.....	5
Step 3 – Install Crossbars To Feet.....	6
Step 4 – Attach Side Channels to Crossbars .....	7
Step 5 – Attach Front Crossbar .....	7
Step 6 – Attach Roller Bar to Roller Bar Brackets .....	8
Roller Bar Alternate Positions .....	9



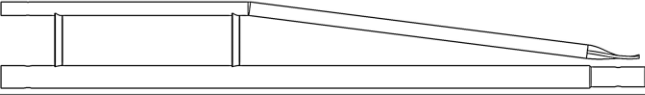
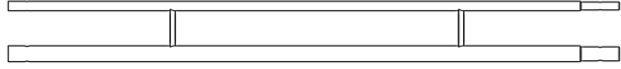
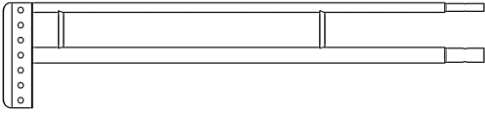
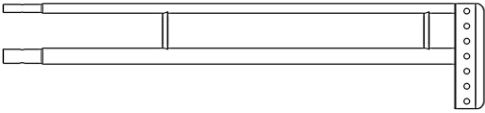

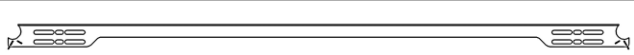
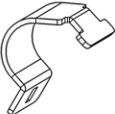
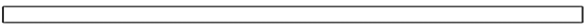

## Before You Begin

- Read all instructions prior to assembling or installing any product.
- **Always locate your installation locations prior to performing any work.**
- **Be sure to put sealant around all threads entering cargo area and between the rubber spacer and roof of vehicle to prevent water from leaking into cargo area.**
- **HAVE THE MOUNTING KIT INSTALLED TO VEHICLE PRIOR TO INSTALLING THIS RACK.**

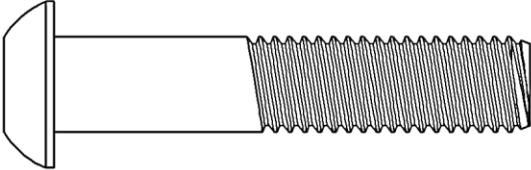
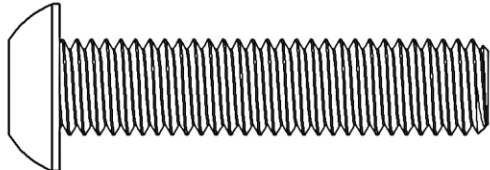
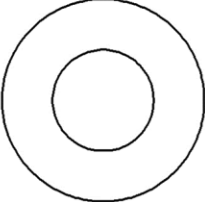
## Parts

NO.	ITEM	PART NUMBER	DESCRIPTION	QTY.
1		8000S-01	FRONT SIDE CHANNEL	2
2		8000S-02	60" CENTER SIDE CHANNEL	2
3		8000S-32	REAR RIGHT SIDE CHANNEL	1
4		8000S-31	REAR LEFT SIDE CHANNEL	1
5		8016S-003	64" FRONT CROSSBAR TUBE	1
6		8016S-01	64" CROSSBAR WELDMENT	3
7		8000A-010	SIDE CHANNEL CLAMP	6
8		8016S-02	64" ROLLER BAR	1
9		101718	WIND DEFLECTOR, 50", 1.625" TUBING, STEEL	1
10		8000S-017	Wind Deflector Clamp, 1.625" Tubing, Steel	3
11		18-80160	ASSEMBLY BOLT KIT	1
12		18-8000A-RB	ROLLER BAR BOLT KIT	1
13		18-31571	HARDWARE KIT	1

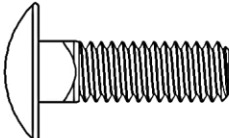
## Hardware (18-80160)

ITEM	HARDWARE TO SCALE	PART NUMBER	DESCRIPTION	QTY.
1			1/2"-13 X 2-1/2" BUTTON HEAD CAP SCREW	2
2		24114	1/2"-13 X 2-1/4" BUTTON HEAD	4
3		11541086	1/2" WASHER	6
4		37695	1/2"-13 THIN LOCKING JAM NUT	6
5		92949A546	1/4"-20 X 1 1/2 BUTTON HEAD	4
6		0167030	1/4"-20 FLANGED LOCK NUT	4
7		21811	5/16-18 X 1" CARRIAGE BOLT	6
8		11104019	5/16-18 FLANGED NYLOCK NUT	6
9		0149489	10-32 X 3/4" PAN HEAD SCREW	3

## Hardware (18-8000A-RB)

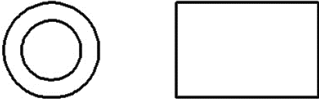
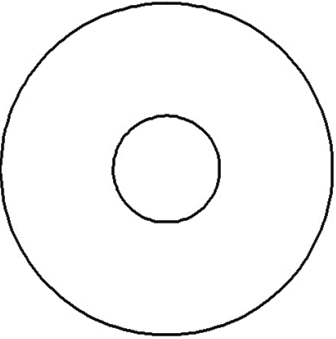
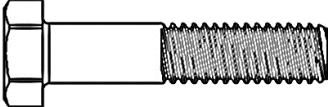
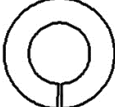
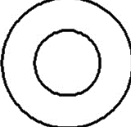
ITEM	HARDWARE TO SCALE	PART NUMBER	DESCRIPTION	QTY.
1		6391K406	OIL-EMBEDDED BRONZE SLEEVE BEARING	2
2		95611A287	CHEMICAL-RESISTANT PVC PLASTIC WASHER FOR 1/2" SCREW SZ, 0.562" ID, 1.75" OD, 0.053"-0.071" THK	4
3		11241181	5/16"-18 X 1-1/2" HEX HEAD BOLT	2
4		1171067	5/16" LOCKING WASHER	2
5		11545144	5/16" FLAT WASHER	2

## Sealant Application



Proper sealant application is critical to preventing water penetration inside the rack AND provides for a stable connection between parts.

- Apply a healthy bead of sealant entirely around every swaged joint as shown. Improper sealing can lead to water penetration.
- Wipe any excess sealant off immediately with a plastic scraper or paper towel. Any smeared sealant can be rubbed off as soon as sealant dries.
- Maintain this seal throughout the life of your rack.

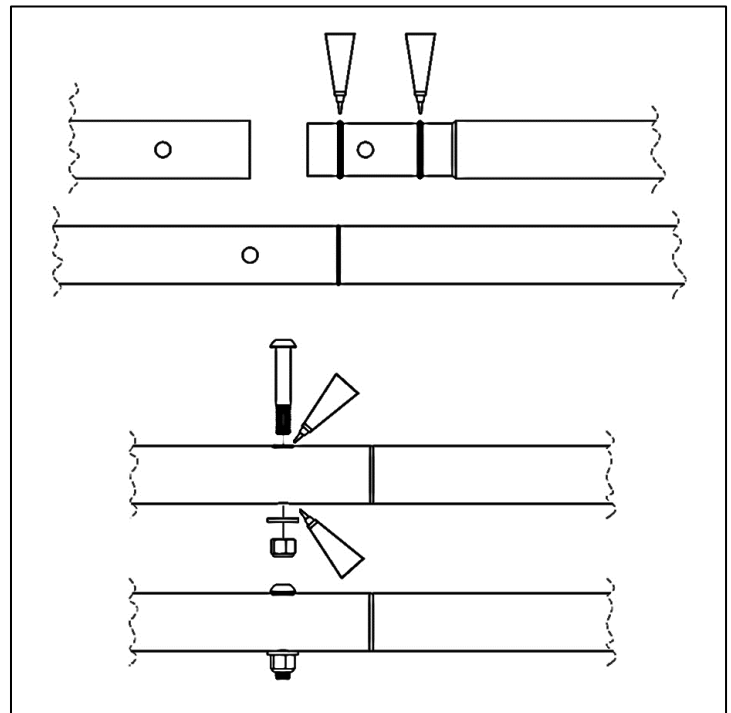

## DO NOT EXCEED MANUFACTURERS WEIGHT CAPACITY FOR ROOF.

### Step 1 – Assemble Side Channels

- Push ends of front side channel onto swaged ends of center side channel.
- Using a 1/4" x 1-1/2" button head bolt and 1/4" flanged lock nut, bolt through upper side channel tubes.
- Using a 1/2" x 2-1/4" button head bolt, 1/2" flat washer, and 1/2" locking jam nut, bolt through lower side channel tubes.
- Repeat for rear side channel.
- Repeat for opposite side channel.
- Tighten the bolts going through top and bottom side-channel tubes.

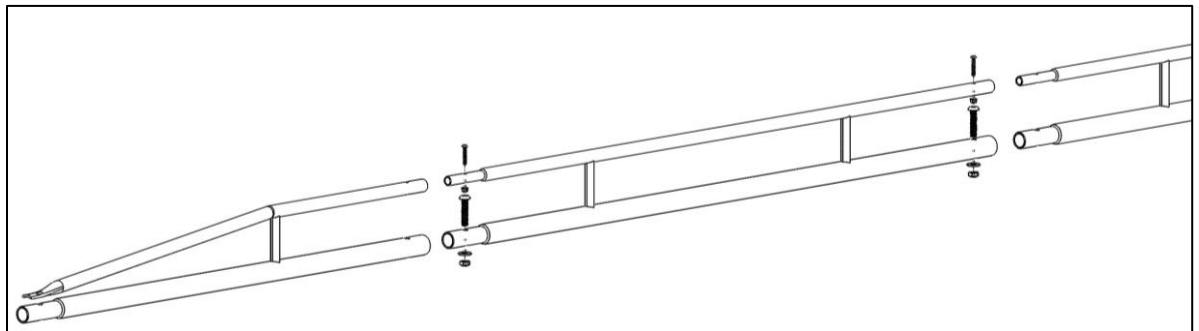
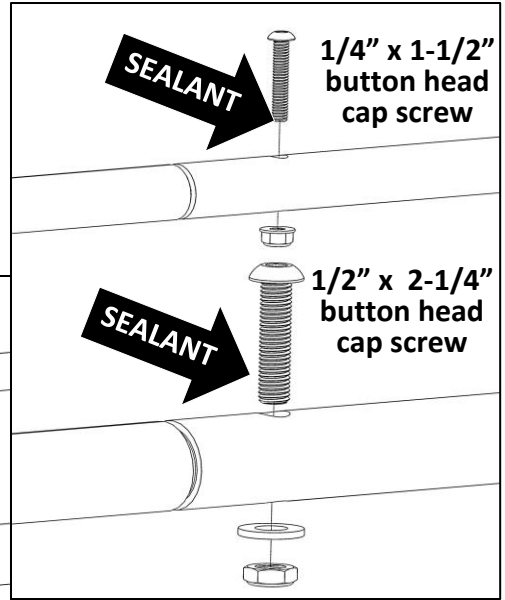
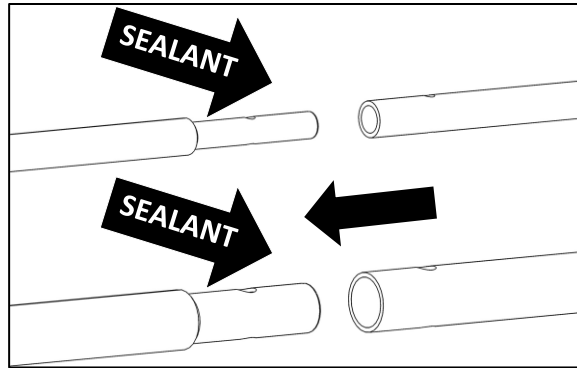

### Step 2 – Attach Wind Deflector to Front Crossbar

- Insert wind deflector clamp-retainer into cutout in wind deflector.
- Hold wind deflector in position with angled edge aimed towards front of vehicle.

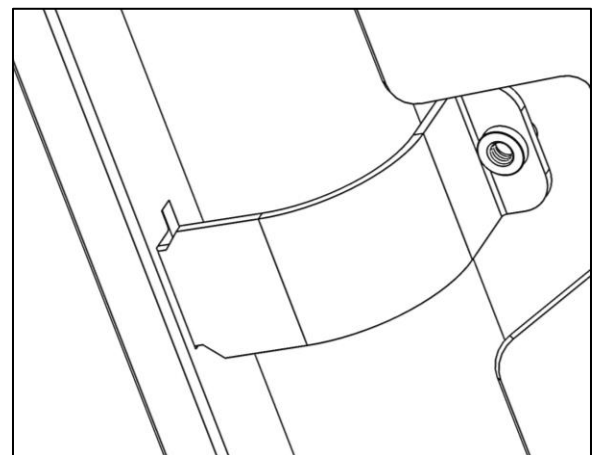
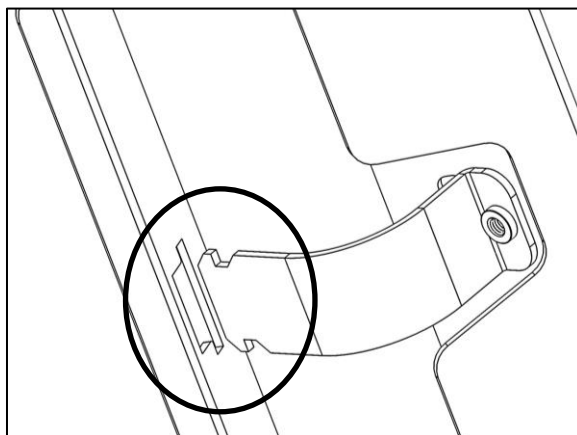

- Fasten a #10 x 3/4" pan head screw through the wind deflector into the press nut in the clamp.
- Repeat for remaining two clamps.
- Tighten.

The best angle for the wind deflector will depend on the vehicle the rack is installed on and will differ for each installation. Small angle adjustments can make a big difference. Ideally the bottom flange of the wind deflector will nearly follow the curvature of the vehicle. The image shown above is approximately the best angle to start with.

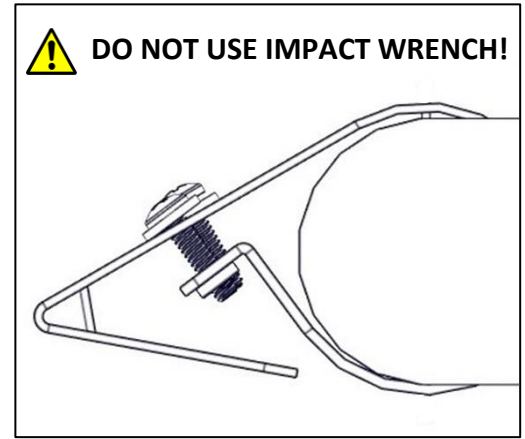

### **Step 3 – Install Crossbars To Feet**

**NOTE: HARDWARE TO ATTACH CROSSBARS TO FEET IS INCLUDED IN MOUNTING KIT.**

- Set crossbar onto feet. **Mounting feet may be installed into either upper or lower slots, based upon clearance required for vehicle.**
- Center crossbar right-to-left with feet and vehicle.

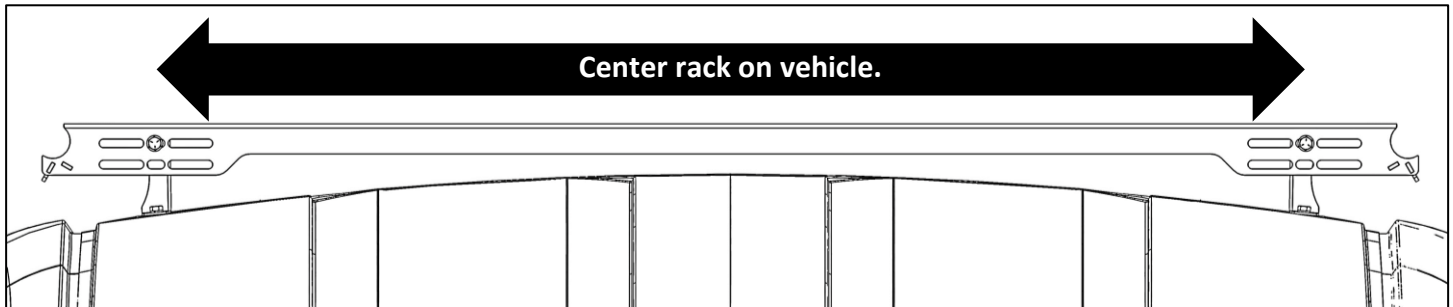

- Using 3/8" x 1" hex head bolts, 3/8" lock nuts, and 3/8" flat washers provided with mounting kit, bolt crossbar to feet.
- Tighten but allow movement.
- Repeat for all remaining crossbars.

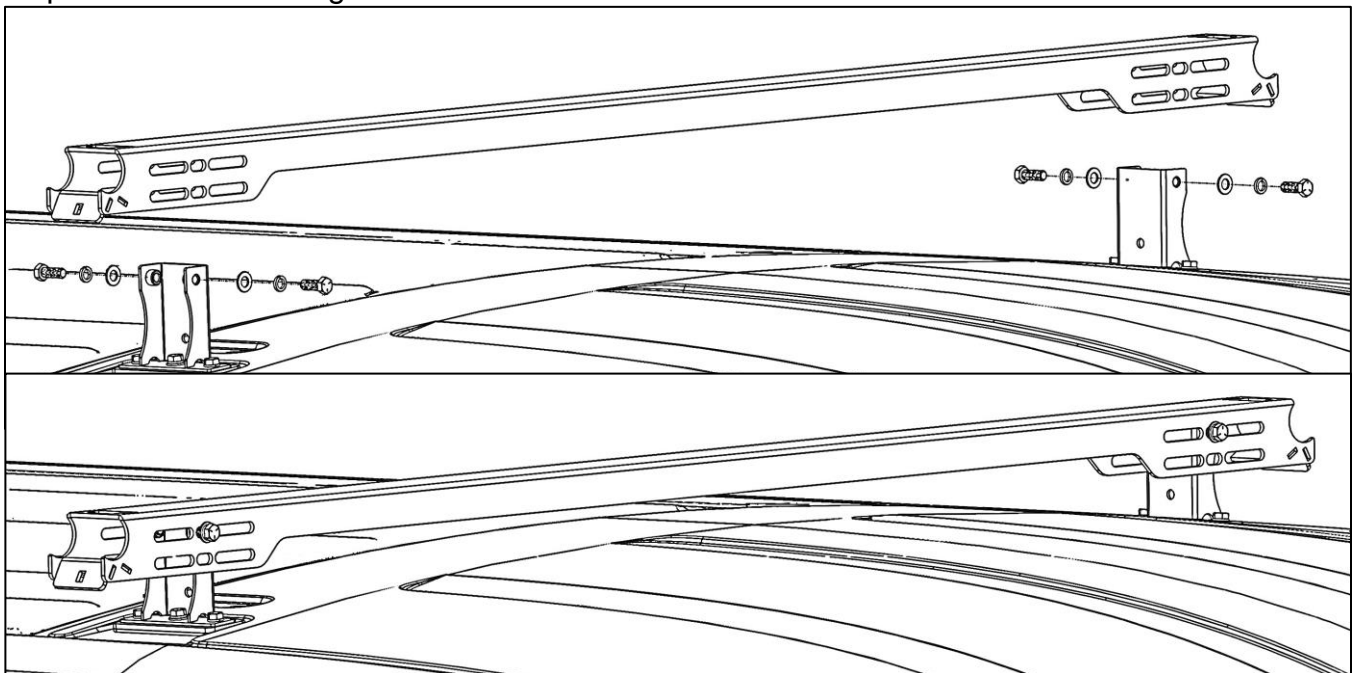



## Step 4 – Attach Side Channels to Crossbars

- Set side channel into round cutout in crossbars in desired position.
- Although rack position may be adjusted later, it is recommended to determine the front-to-back position of the rack at this point.
- Insert a side channel clamp into cutout in each crossbar with interior diameter facing upward.
- For each side channel clamp, use a 5/16" x 1" carriage bolt and 5/16" flanged lock nut to bolt side channel clamp to crossbar.
- LOOSELY tighten.

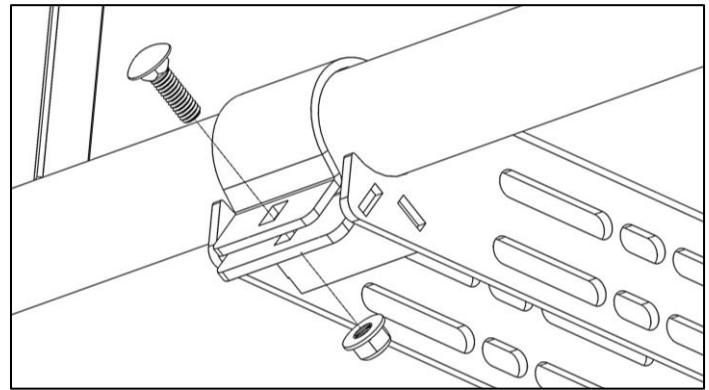
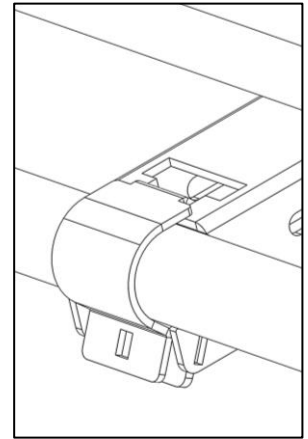
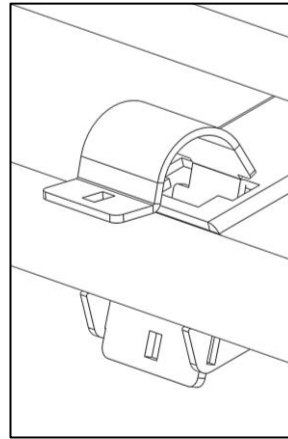
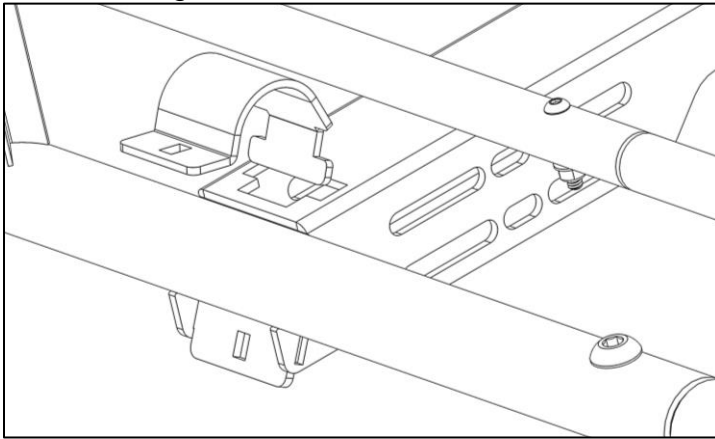
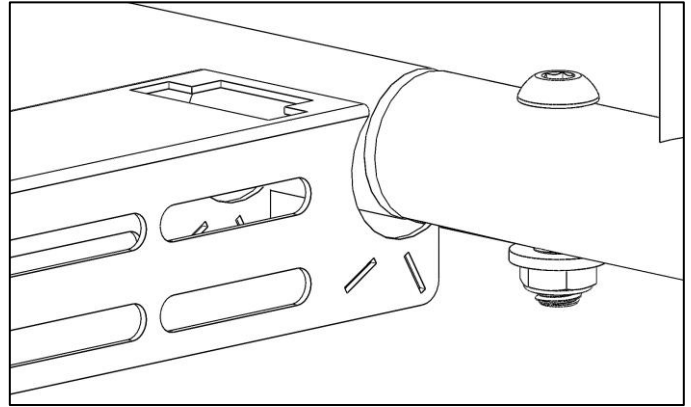

## Step 5 – Attach Front Crossbar

- Push front crossbar onto swaged end of front side channel. **Be sure to align holes in both and be sure flat face of wind deflector is on top.**
- Using a 1/2" x 2-1/2" button head cap screw, 1/2" flat washer, and 1/2" locking jam nut, bolt through front side channel and front crossbar.
- Tighten.
- Repeat for opposite side.

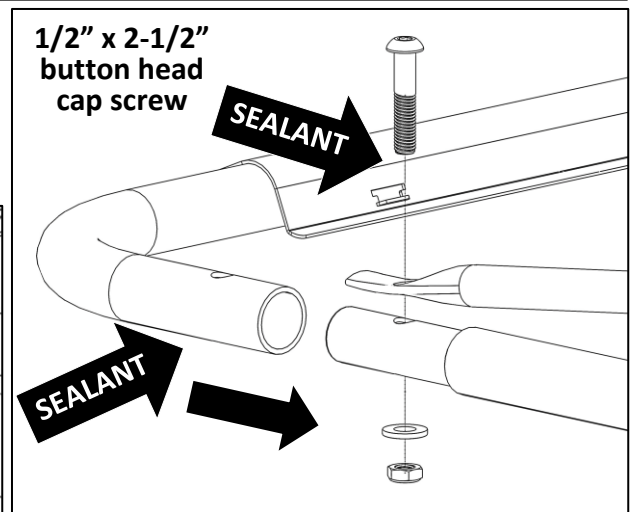
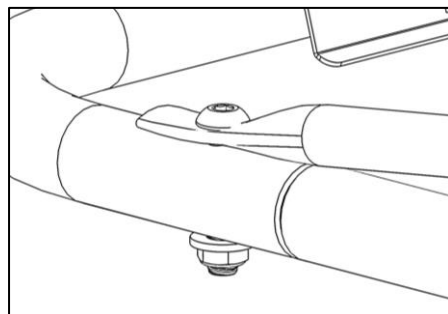



## Step 6 – Attach Roller Bar to Roller Bar Brackets

**Note:** The center roller bar mounting position is best for load bearing. Several positions are provided to accommodate different loading positions.

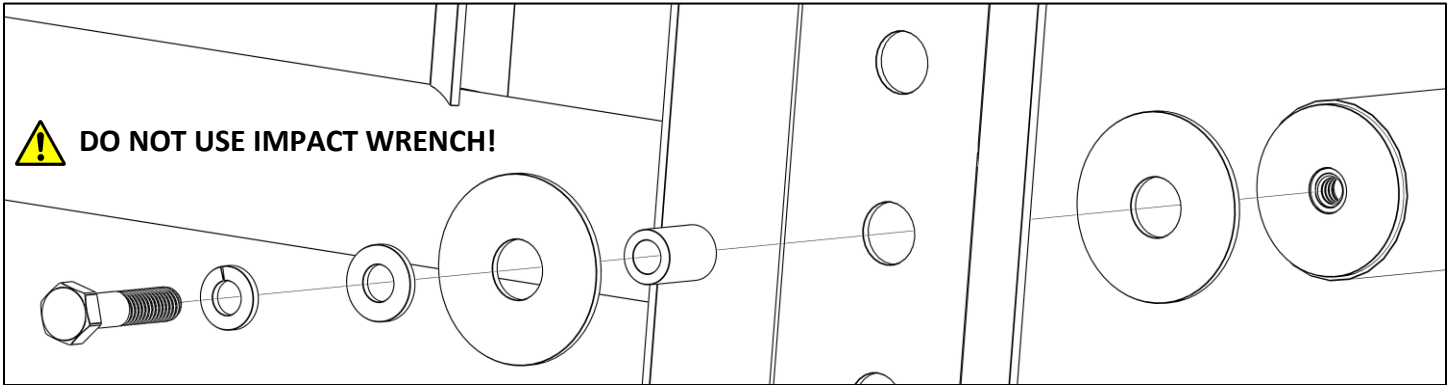

- Using a 5/16" x 1-1/2" hex head bolt, bolt through the following and into the end of the roller bar.
  - a 5/16" lock washer,
  - a 5/16" flat washer,
  - two plastic washers (one on each side of roller bar bracket),
  - a roller bar bracket, and
  - a roller bearing.
- LOOSELY tighten hardware.
- Repeat for opposite side.
- **Be sure the rear roller bar is hanging off the rear of the vehicle enough so that when placing a ladder on the rack, it does not come into contact with the rear of the vehicle.**
- **Check that the rack is square to the vehicle and mounts.**

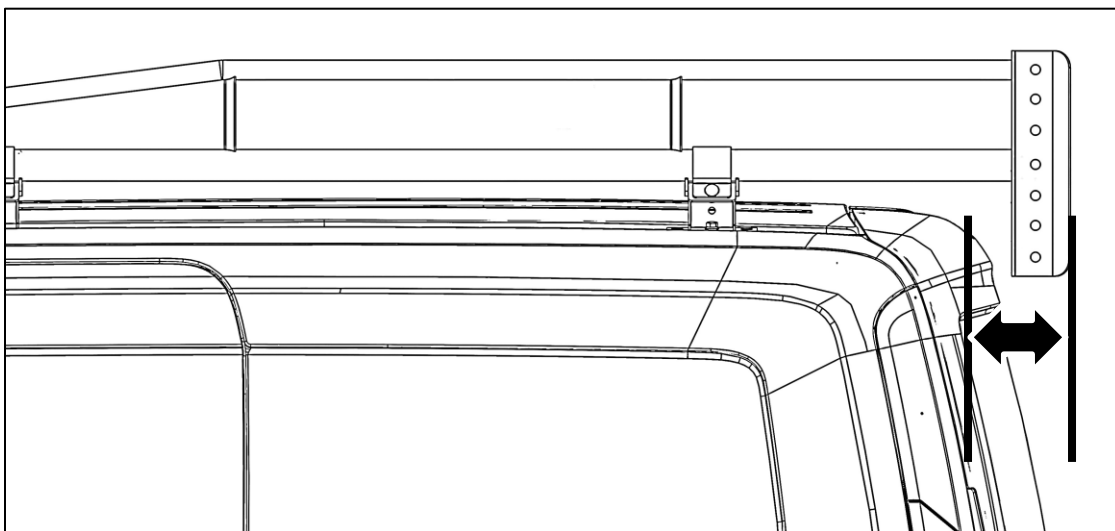

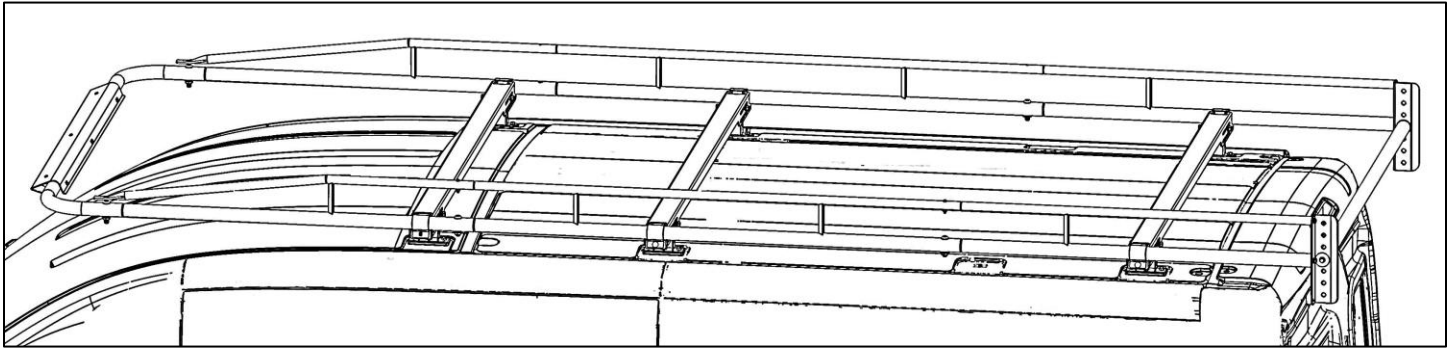

**GO BACK AND TIGHTEN ALL HARDWARE.**

**INSTALLATION AND ASSEMBLY ARE COMPLETE.**

### **Roller Bar Alternate Positions**

**Note: The center mounting position of the roller bar is recommended for maximum load bearing applications. Several locations are provided to accommodate different loading positions but at lower load accommodation.**

