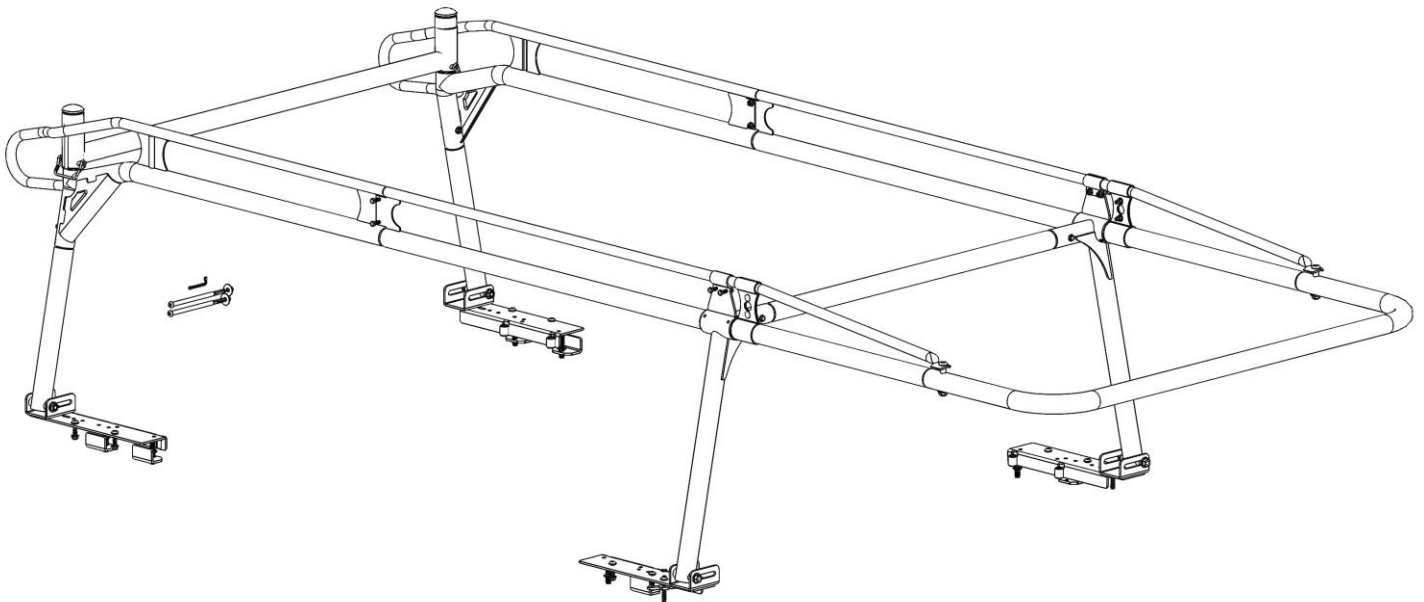


Holman

Installation Guide 90001



Holman
Rancho Cordova, CA 95742
800-343-7486
InstallationSupport@Holman.com

PLEASE READ ALL INSTRUCTIONS AND WARNINGS PRIOR TO ASSEMBLING, INSTALLING, AND USING THIS PRODUCT.

Warning



Always check for wires, fuel tanks and lines, brake lines and other important vehicle functionality items prior to drilling and installing all products.



Too much weight will greatly reduce the stability of your vehicle. Holman makes no representation or warranty as to the amount of weight your vehicle can safely carry. For guidance, we recommend that you consult the vehicle manufacturer. **AT NO TIME SHOULD THE WEIGHT OF THE VEHICLE, RACK, DRIVER, PASSENGERS AND CARGO LOADED ON A HOLMAN RACK EXCEED EITHER THE GROSS VEHICLE WEIGHT RATIO (GVWR) OR THE GROSS AXLE WEIGHT RATIO (GAWR) AS SPECIFIED BY THE VEHICLE MANUFACTURER.**



Do not use your rack with the rear cross bar removed. Removal of rear crossbar will affect structural integrity of the rack.



Secure all payloads properly for safe transportation.



A large area is required to assemble rack. Be sure to keep area clear of trip and fall hazards.

Before You Begin

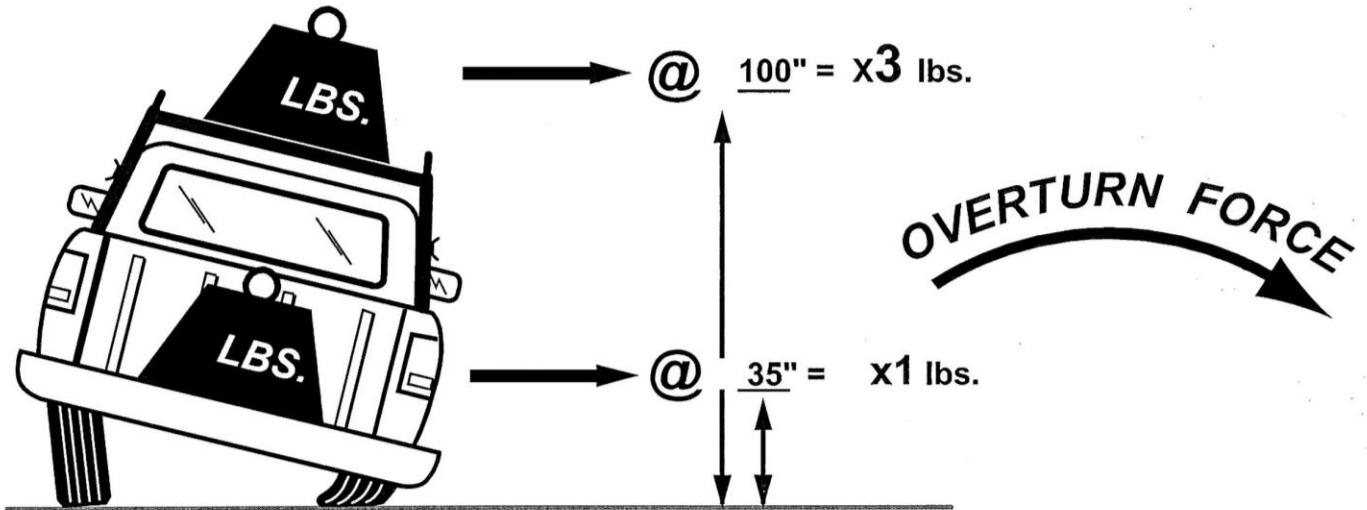
- Read all instructions prior to assembling or installing any Holman product.
- Follow each step in proper sequence, for ease and speed in assembling your Holman rack.
- **PROPER SEALANT APPLICATION IS CRITICAL TO ENSURE SOLID ASSEMBLY, PREVENTING RATTLING, AND WATER PENETRATION INSIDE THE RACK. Apply a healthy bead of sealant entirely around every swaged joint and every bolt going through tubing. Improper sealing can lead to water penetration. Lack of sealant and loose hardware can also lead to rattling.**

Tools Needed

1/2", 9/16", 3/4" Sockets and Wrench	1/2", 9/16", 3/4" Box Wrenches
Rubber Mallet	5/16"* , 7/32" Hex Key Wrench
13/32" Drill Bit (optional)	Drill (optional)

* Included

DON'T OVERLOAD YOUR VEHICLE!



WEIGHT CARRIED ABOVE THE FLOOR OF THE TRUCK BED (E.G. ON AN OVERHEAD TRUCK RACK) WILL SIGNIFICANTLY INCREASE THE VEHICLE'S TENDENCY TO OVERTURN. ALWAYS KEEP HEAVY LOADS EVENLY DISTRIBUTED AND AS LOW AS POSSIBLE. IT IS IMPORTANT TO NOTE THAT THE HOLMAN RACK LOAD BEARING CAPACITY OF 1700 LBS. MAY BE GREATER THAN YOUR TRUCK'S GAWR OR GVWR CAPACITY, AND IS PROBABLY GREATER THAN THE WEIGHT THAT CAN BE SAFELY CARRIED OVERHEAD. RETIGHTEN ALL BOLTS AFTER FIRST USE, PERIODICALLY CHECK BOLTS FOR TIGHTNESS.

For TECHNICAL SUPPORT Call:


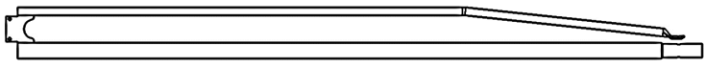

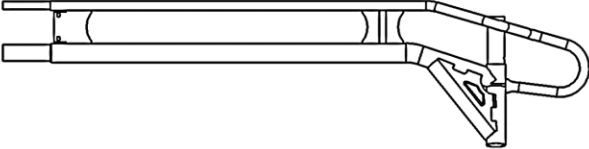
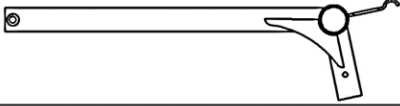
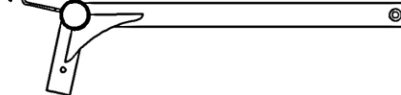

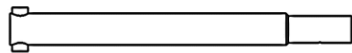
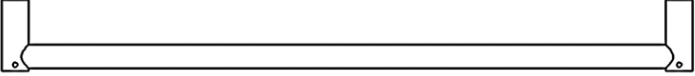
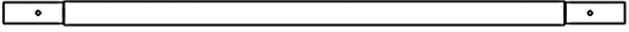

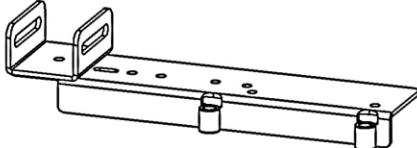
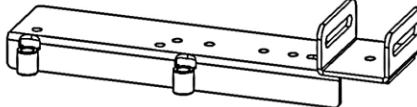
1.800.343.7486

or email: InstallationSupport@Holman.com

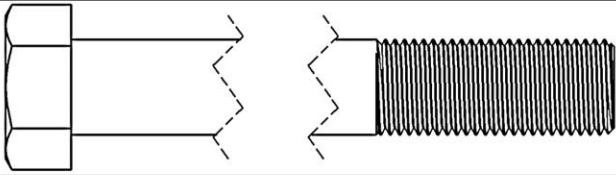
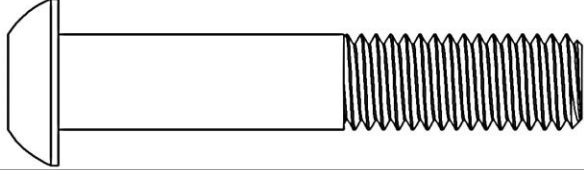
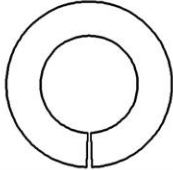
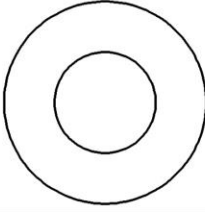
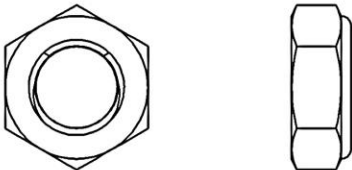
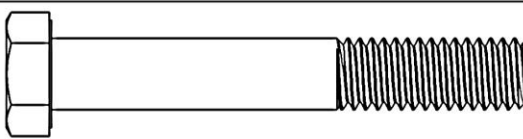
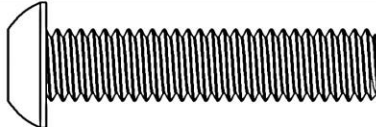
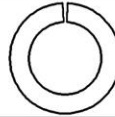
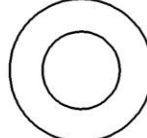

Table of Contents

Before You Begin	1
Parts	4
Hardware (18-90001)	5
Hardware (18-00001GM).....	7
Hardware (18-90001M).....	7
Sealant Application	9
Installation Notes	9
Step 1A – Install Feet – Standard Installation:.....	10
Step 1B – Permanent Installation:	12
Step 2 – Assemble Side Channels	12
Step 3 – Install Front Leg Assemblies	13
Step 4 – Install Rear Legs	13
Step 5 – Attach Side Channel to Center Cross Tube	14
Step 6 – Attach Front U-tube	14
Step 7 – Attach Front Rail Brackets.....	14
Step 8 – Attach Rear Crossbar	15
Step 9 – Attach Rack to Feet.....	15
Step 10 – Tighten Hardware in Order.....	16


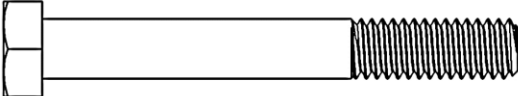
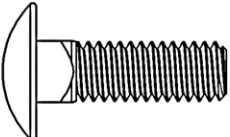
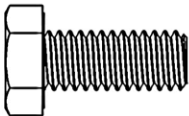
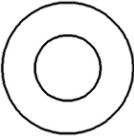


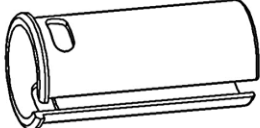
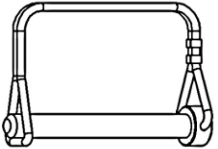
Parts

NO.	ITEM	PART NUMBER	DESCRIPTION	QTY.
1		11-01002A	FRONT U TUBE	1
2		13-00850A	FRONT SIDE CHANNEL	2
3		13-00990A	REAR SIDE CHANNEL RH PS 18DEG REV	1
4		13-00989A	REAR SIDE CHANNEL LH DS 18DEG REV	1
5		13-00855RA	FRONT LEG LH DS	1
6		13-00855LA	FRONT LEG RH PS	1
7		12-00202-1A	FRONT LEG CLAMP BRACKET	2
8		13-01005A	REAR LEG, 18DEG REV	2
9		13-00852A	REAR CROSSBAR	1
10		11-01015A	CENTER CROSS TUBE	1
11		11-01013A	FRONT RAIL BRACKET	4
12		100807	FOOT ASSY FRONT RH PS	2
13		100805	FOOT ASSY FRONT LH DS	2
14		18-90001	HARDWARE KIT	1
15		18-00001-GM	HARDWARE KIT	1
16		18-90001M	HARDWARE KIT	1

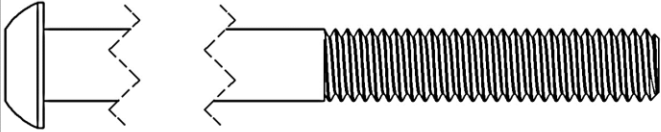
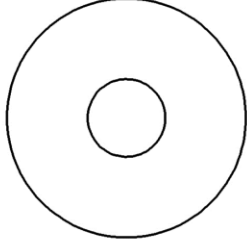
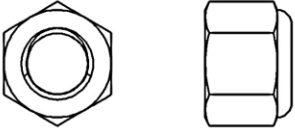
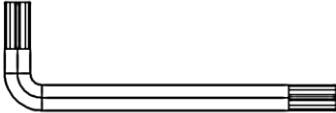
Hardware (18-90001)

ITEM	HARDWARE TO SCALE	PART NUMBER	DESCRIPTION	QTY.
1		11105810	1/2"-13 X 3-3/4" HEX HEAD BOLT	4
2			1/2-13 X 2-3/4 SCREW, BUTTON HEAD	2
3		71071	1/2" LOCK WASHER	6
4		11541086	1/2" WASHER	10
5		37695	1/2"-13 THIN LOCKING JAM NUT	6
6		11137260	3/8-16 X 2-1/2" HEX HEAD BOLT	2
7		94095	3/8"-16 X 1-3/4" BUTTON HEAD CAP SCREW	8
8		0123496	3/8" SPLIT LOCK WASHER	2
9		1133082	3/8" WASHER	20
10			3/8"-16 JAM NYLOCK NUT	10

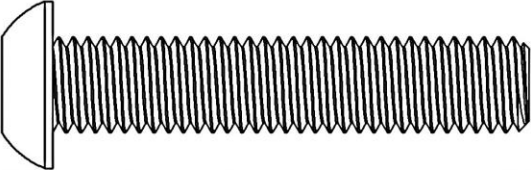
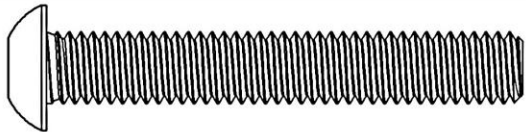
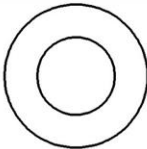

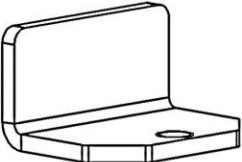
Hardware (18-90001) (Continued)

ITEM	HARDWARE TO SCALE	PART NUMBER	DESCRIPTION	QTY.
11		0135144	3/8"-16 X 3/8" SET SCREW	4
12			5/16"-18 X 2-1/2" HEX HEAD BOLT	2
13		21811	5/16-18 X 1" CARRIAGE BOLT	4
14			5/16-18 X 3/4" HEX HEAD BOLT	8
15		11545144	5/16" FLAT WASHER	24
16		37689	5/16"-16 THIN NYLON INSERT LOCKNUT	14
17	 NOT TO SCALE	100864	PLASTIC CAP	2
18	 NOT TO SCALE	100863	PLASTIC CROSSBAR INSERT	2
19	 NOT TO SCALE		WIRE LOCK CLEVIS PIN	2

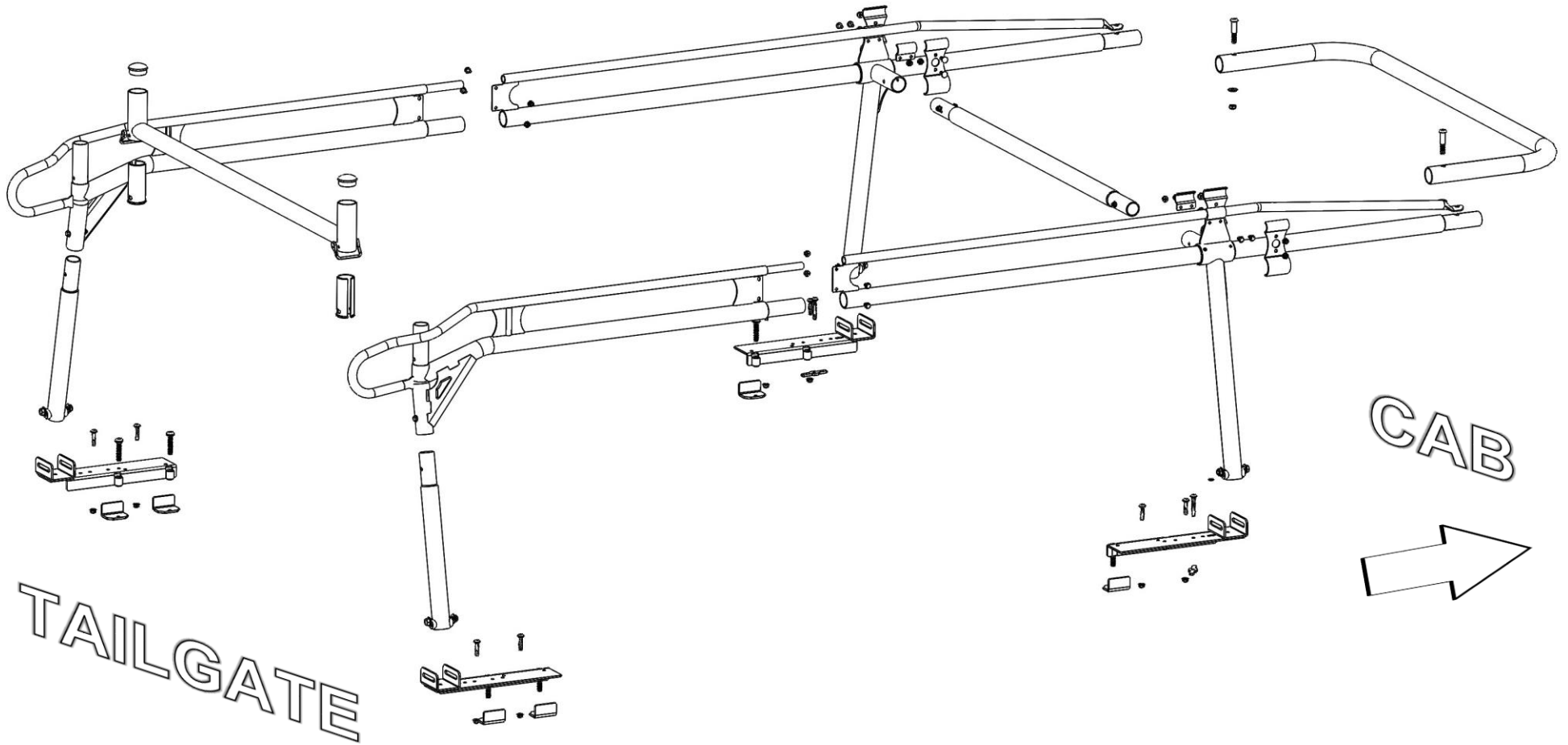
Hardware (18-00001GM)

ITEM	HARDWARE TO SCALE	PART NUMBER	DESCRIPTION	QTY.
1		-	3/8"-16 X 8" BH	2
2		33220	3/8" FENDER WASHER	2
3		0169791	3/8"-16 LOCK NUT	2
4	 NOT TO SCALE	36315	T15 TORX WRENCH	1

Hardware (18-90001M)

ITEM	HARDWARE TO SCALE	PART NUMBER	DESCRIPTION	QTY.
1		0185355	1/2"-13 X 2-1/2" BUTTON HEAD BOLT	6
2		94718	3/8"-16 X 2.5" SOCKET CAP SCREW	2
3		1133082	3/8" WASHER	2
4		11-00112	3/8"-16 T-NUT	2
5	 NOT TO SCALE	100578	RAIL CLAMP, FULL SIZE	6

TRUCK RACK EXPLODED VIEW

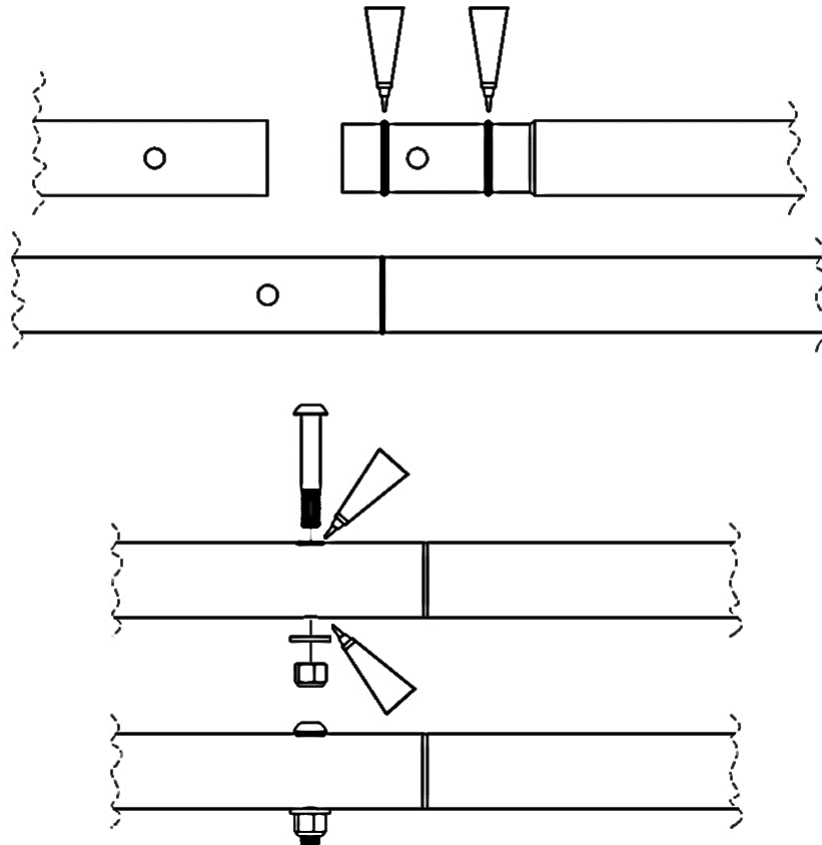


DO NOT EXCEED MANUFACTURERS WEIGHT CAPACITY FOR ROOF.

Sealant Application

 Proper sealant application is critical to preventing water penetration inside the rack AND provides for a stable connection between parts.

- Apply a healthy bead of sealant entirely around every swaged joint as shown. Improper sealing can lead to water penetration.



- Wipe any excess sealant off immediately with a plastic scraper or paper towel. Any smeared sealant can be rubbed off as soon as sealant dries.
- **Maintain this seal throughout the life of your rack.**

Installation Notes

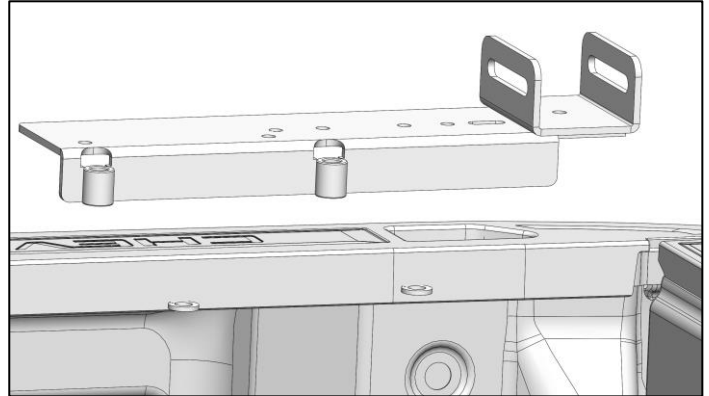
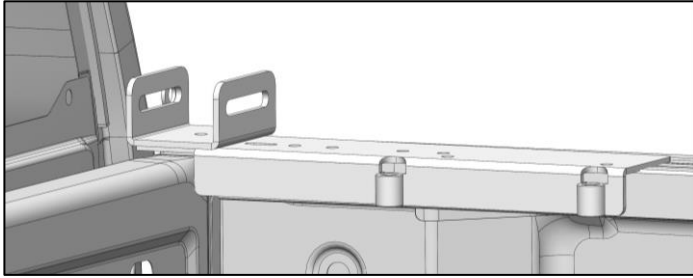
- There are 2 methods of installation.
 - (a) clamping the feet to the side of the bed with rail clamps and securing and bolting the feet to the stake pockets;

OR

- (b) drilling and permanently mounting through the side rails.

Step 1A – Install Feet – Standard Installation:

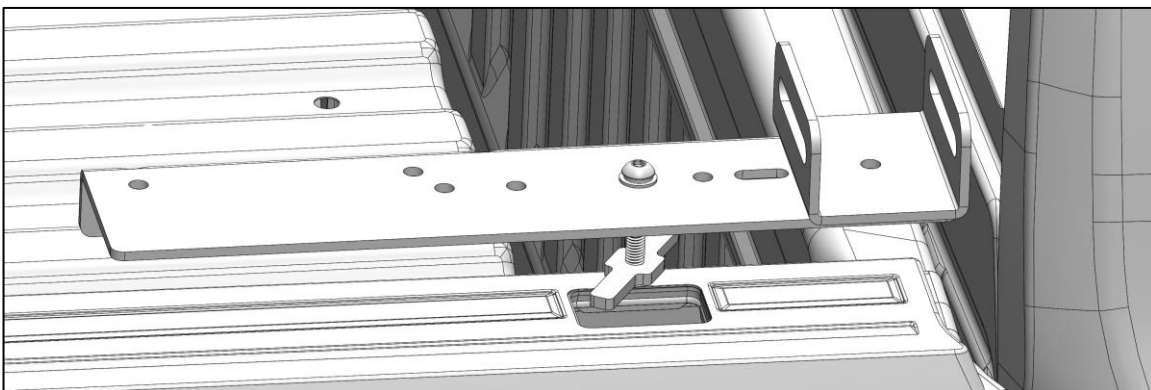
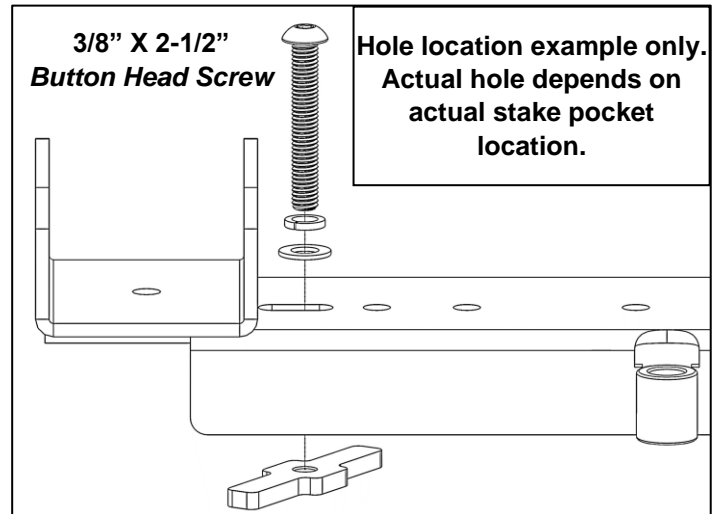
- Position a footplate on the bedrail, as far forward as possible, with the inside of the bed is against the downward flange on the foot.



- Position a second footplate on the bedrail, with the foot U-bracket saddle located near the rear stake pocket.
- If there are covers over the stake pockets, remove the covers. Some stake pockets are covered with solid plastic. Bed rails should be cut to access.
- Determine which pre-drilled hole falls over the stake pocket. For most trucks, the feet have been designed to have at least one hole that will be near center of the stake pocket.
- If the none of the pre-drilled holes fall over the stake pocket, mark and drill a 13/32” hole in the foot plate that is approximately over the center of the stake pocket.

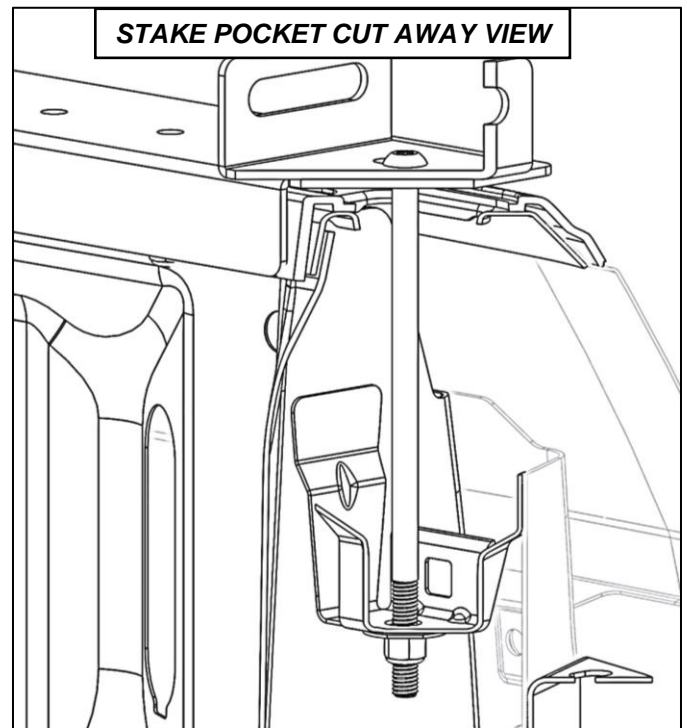
Front Foot Stake Pocket:

- Put 3/8” x 2-1/2” button head screw with 3/8” lock washer and 3/8” washer through footplate and start T-nut as shown.
- Maneuver the T-nut inside the stake pocket, push the footplate forward against the bulkhead, and then snug tighten the T-nut up against the underside of the truck bed rail. **Be sure inside of the bed is against downward flange on the foot.**
- LOOSELY tighten T-nut inside stake pocket.



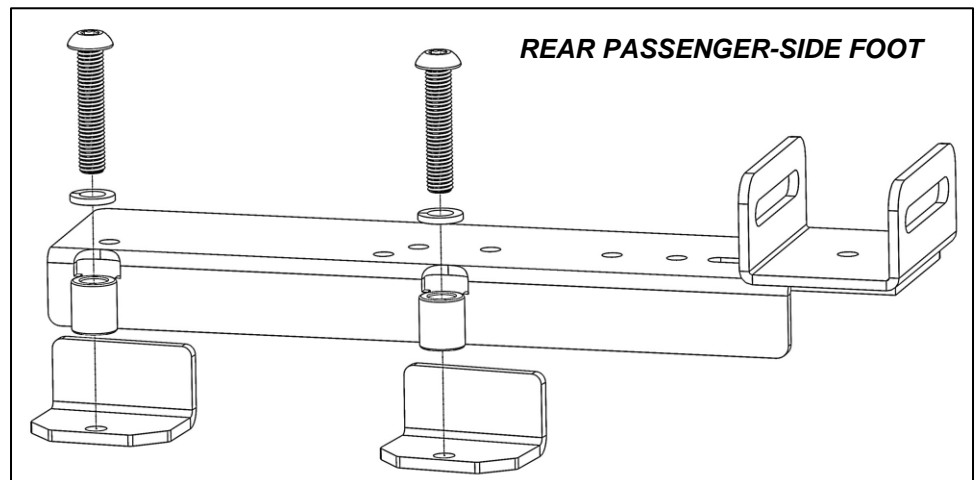
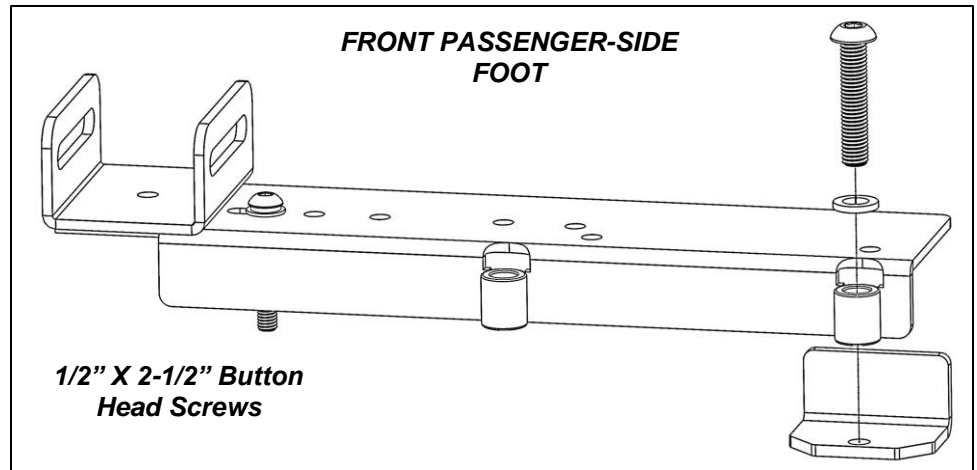
Rear Foot Stake Pocket - Ford and Chevy:

- Remove taillight. A T15 Torx wrench is provided to remove Chevy taillights.
- On the rear foot only, insert the 3/8" x 8" button head screw through the hole in the rear slotted channel and the hole in the bottom of the rear stake pocket.
- Install the 3/8" fender washer and 3/8" lock nut onto the 3/8" x 8" button head screw.
- Loosely tighten.



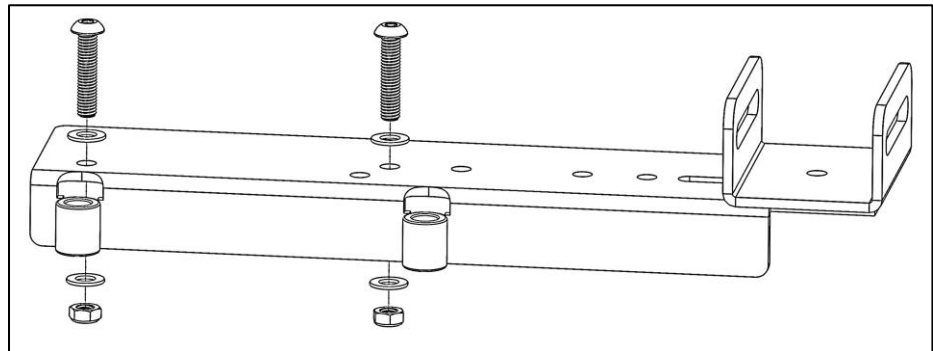
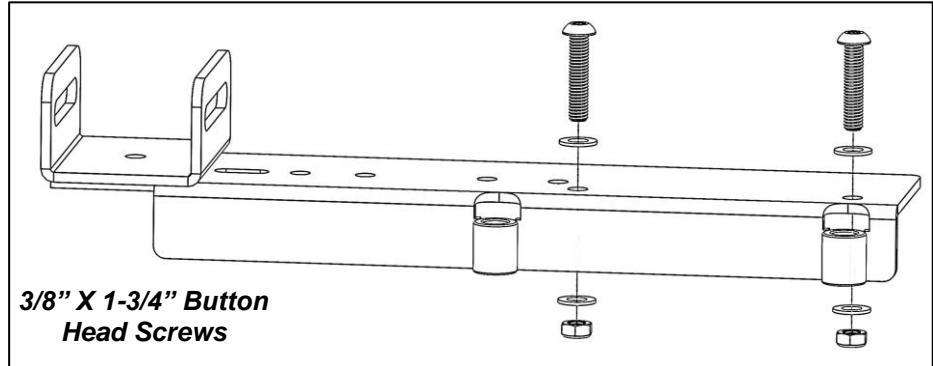
Rear Foot All Vehicles:

- Insert a 1/2" x 2-1/2" button head screw with 1/2" lock washer, through saddle bushings inside of foot, into a rail clamp, as shown.
- Pressing foot tight against inside of bed rail, position rail clamp beneath bedrail, clear of any obstacles.
- Snug tighten bolt, clamping foot to bed rail hold the front footplate in position.
- Repeat for other side.



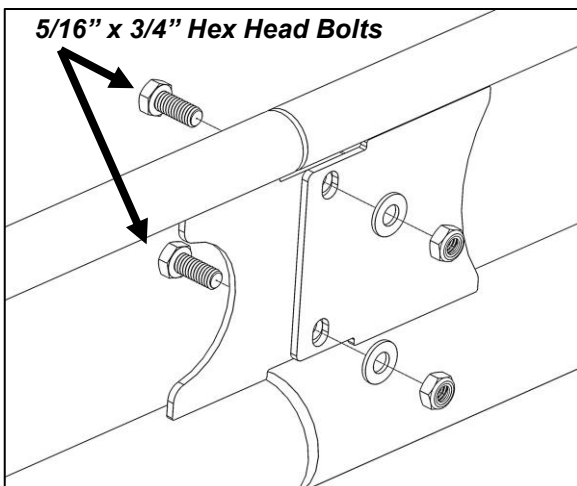
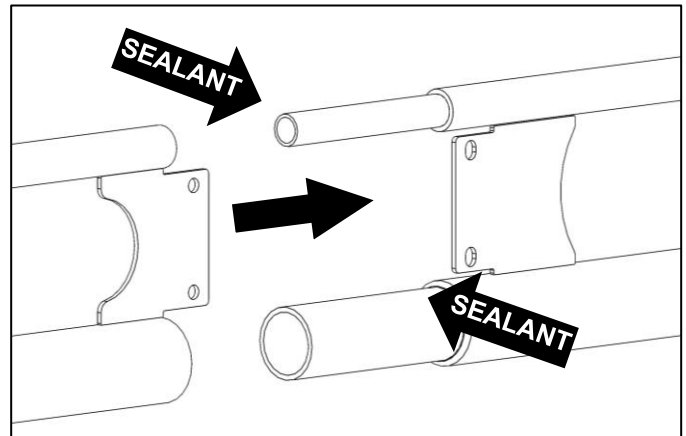
Step 1B – Permanent Installation:

- Position front footplate on the truck bedrail, as far forward as possible, as per above.
- Position rear footplate on the bedrail, with foot U-bracket saddle located near rear stake pocket.
- Locate the best hole in the footplate for drilling through the bed rail. We recommend using the hole farthest from the foot U-bracket saddle and another hole nearer the U-bracket saddle.
- Using a 13/32" drill bit, drill through the bed rails in the location of the holes selected.
- Using a 3/8" x 1-3/4" button head screw, bolt through foot and bed, into a 3/8" washer and 3/8" jam nut.
- Snug tighten.
- Repeat for opposite side.



Step 2 – Assemble Side Channels

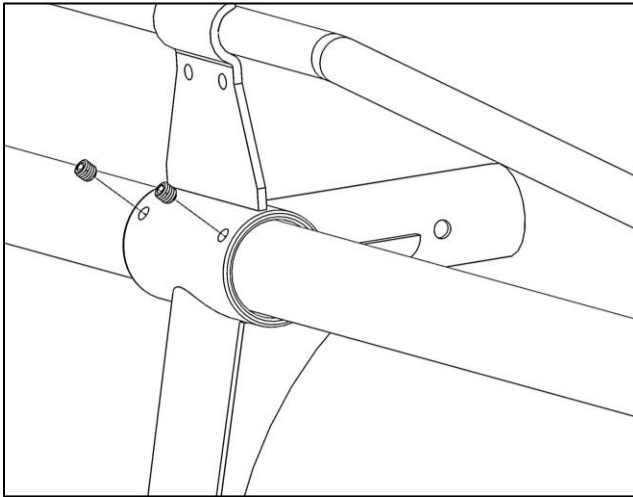
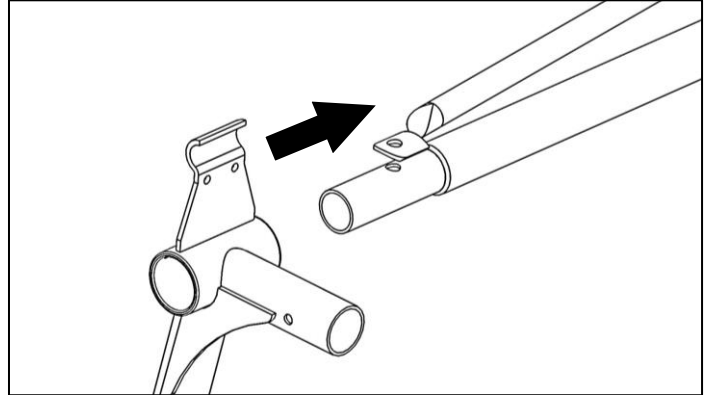
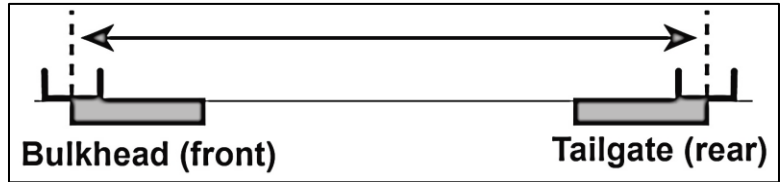
- Apply sealant entirely around each swaged joint.
- Push rear side channel into front side channel until holes in gussets align.



- Using 5/16" x 3/4" hex head bolts, 5/16" washers, and 5/16" lock nuts, bolt front side channel to rear side channel.
- TIGHTEN hardware.
- Remove excess sealant.
- Repeat for second front and rear sided channels.

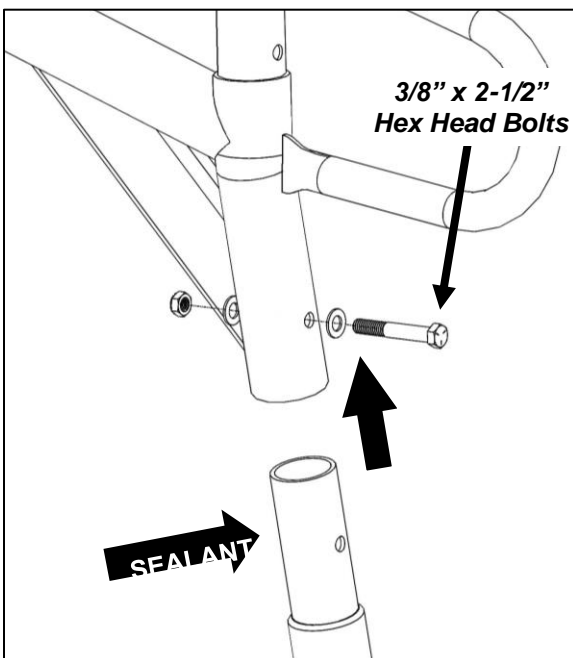
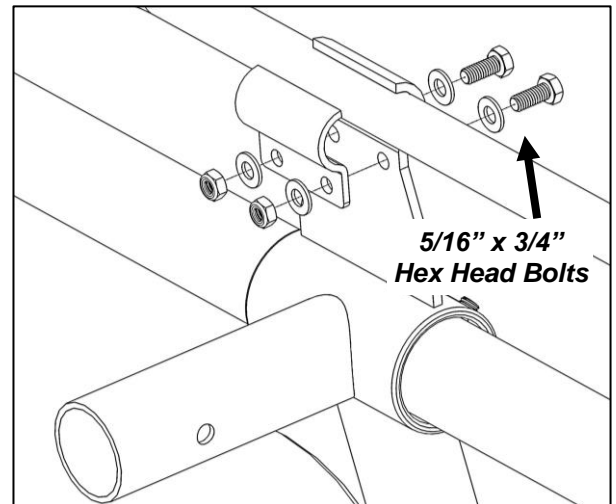
Step 3 – Install Front Leg Assemblies

- Measure center to center distance between U-brackets on front and rear feet.
- Slide front leg LH DS over the LH DS front side-channel bottom-tube. **Be sure the legs are angled in the same direction.**
- Position front leg assembly at the distance measured.



- LOOSELY TIGHTEN 3/8" set screws into threaded holes in side channel.
- Repeat for opposite RH PS front leg and side channel.

- Using 5/16" x 3/4" hex head bolts, 5/16" washers, and 5/16" lock nuts, LOOSELY bolt front leg clamp bracket to front leg assembly. **DO NOT TIGHTEN.**
- Repeat for opposite side.

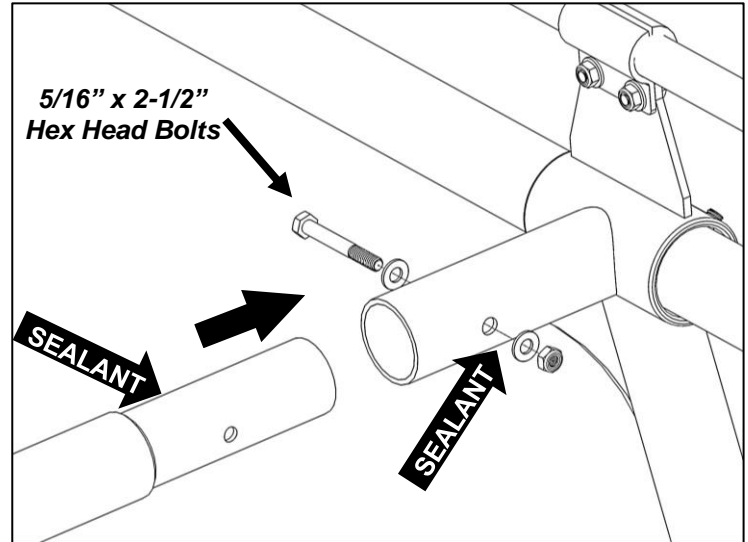


Step 4 – Install Rear Legs

- Apply sealant entirely around each swaged joint.
- Slide leg into rear side channel until holes in leg and side channel align.
- Using 3/8" x 2-1/2" hex head bolt, 3/8" flat washers, and 3/8" lock nut, LOOSELY bolt leg to side channel.
- Remove excess sealant.
- Repeat for opposite side.

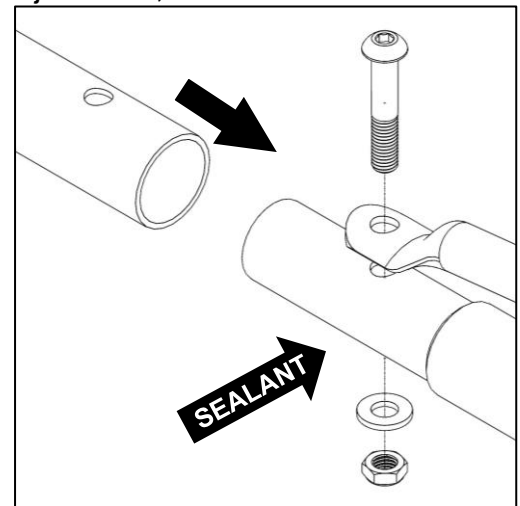
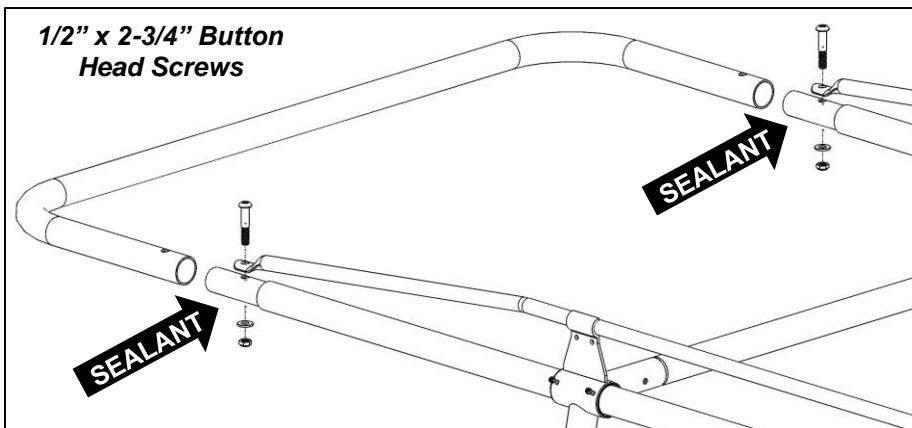
Step 5 – Attach Side Channel to Center Cross Tube

- Apply sealant entirely around a swaged joint on center cross tube.
- Insert swaged joint into receiver tube on front leg assembly until holes in both align.
- Apply sealant into holes in leg assembly.
- Using 5/16" x 2-1/2" hex head bolt, 5/16" washers, and 5/16" lock nut, LOOSELY bolt cross tube to leg assembly.
- Remove excess sealant.
- Repeat for other side.



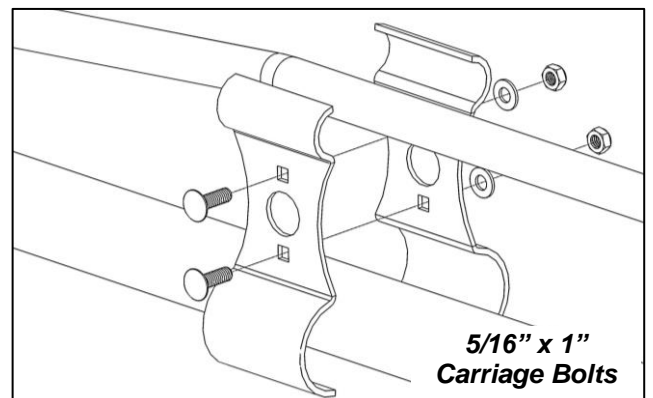
Step 6 – Attach Front U-tube

- Apply sealant entirely around swaged joints on BOTH of the front side channels.
- Insert swaged joints of both side channels into U-tube until holes on both sides align.
- Using 1/2" x 2-3/4" button head screws, 1/2" washers, and 1/2" jam nuts, LOOSELY bolt the U-tube to side channels.
- Remove excess sealant.



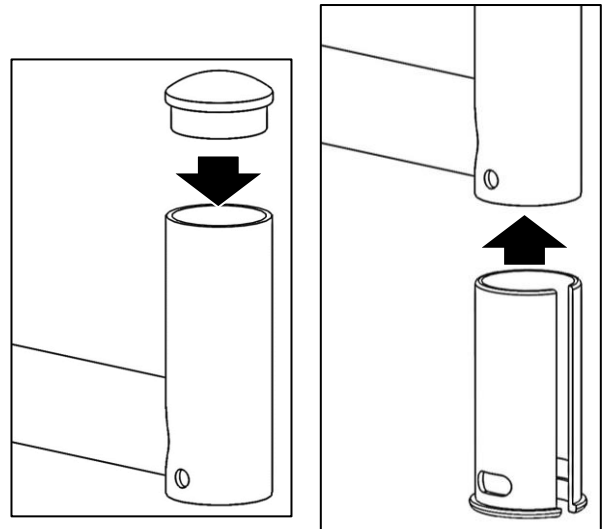
Step 7 – Attach Front Rail Brackets

- Hold two front rail brackets on either side of the front side channel just before the point where the top rail bends.
- Using 5/16" x 1" carriage bolts, 5/16" washers, and 5/16" lock nuts, bolt the two front rail brackets together, clamping the side channel between. **Be sure carriage bolt are facing outwards.**
- Tighten.
- Repeat for opposite side.

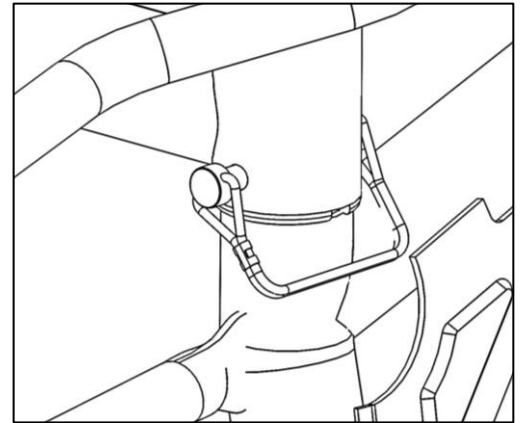


Step 8 – Attach Rear Crossbar

- Using a rubber mallet, tap a plastic cap into the top of the tube at each end of the rear crossbar. Be sure to install the cap in the tall end of the tube, as shown.
- Insert a plastic crossbar insert into one end of rear crossbar. Be sure insert is oriented as shown.
- Rotate plastic crossbar insert so slots align with holes in crossbar.
- Slide rear crossbar simultaneously onto receiver tubes on both rear side channel until holes in crossbar and side channel align.



- Insert pin through holes in rear crossbar. Lock pin in place by hooking wire lock over opposite end of pin.

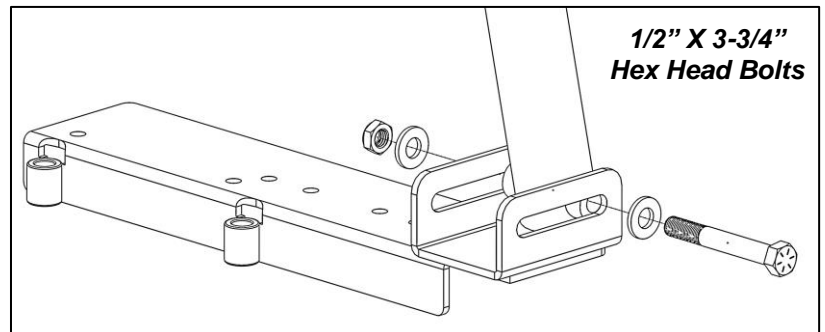


Step 9 – Attach Rack to Feet

- Lift rack and set legs into foot saddles.

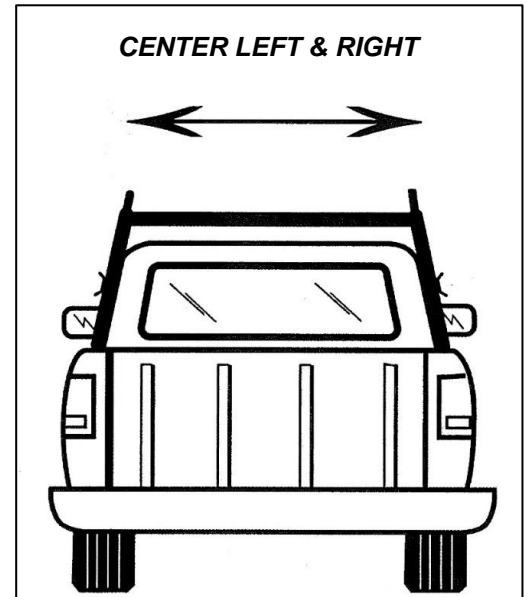


- Using 1/2" x 3-3/4" hex head bolts, 1/2" flat washers, and 1/2" jam nut, **LOOSELY** bolt the feet to the foot U-bracket saddles. **DO NOT TIGHTEN. THESE BOLT ARE LAST TO BE TIGHTENED.**



Step 10 – Tighten Hardware in Order

1. Holding feet against the inside of the bed rails, tighten hardware to secure the feet to the bed rails.
2. Starting at the FRONT and TOP, tighten side channel hardware.
3. Tighten leg hardware.
4. Check that rack is centered side-to-side on vehicle.
5. Holding legs in position, tighten 1/2" hardware connecting rack to U-bracket saddle on feet.



GO BACK AND CHECK THAT ALL HARDWARE IS TIGHTENED.

INSTALLATION AND ASSEMBLY ARE COMPLETE.

