

Holman

Assembly and Installation Guide

Pro II Truck with Cap Rack

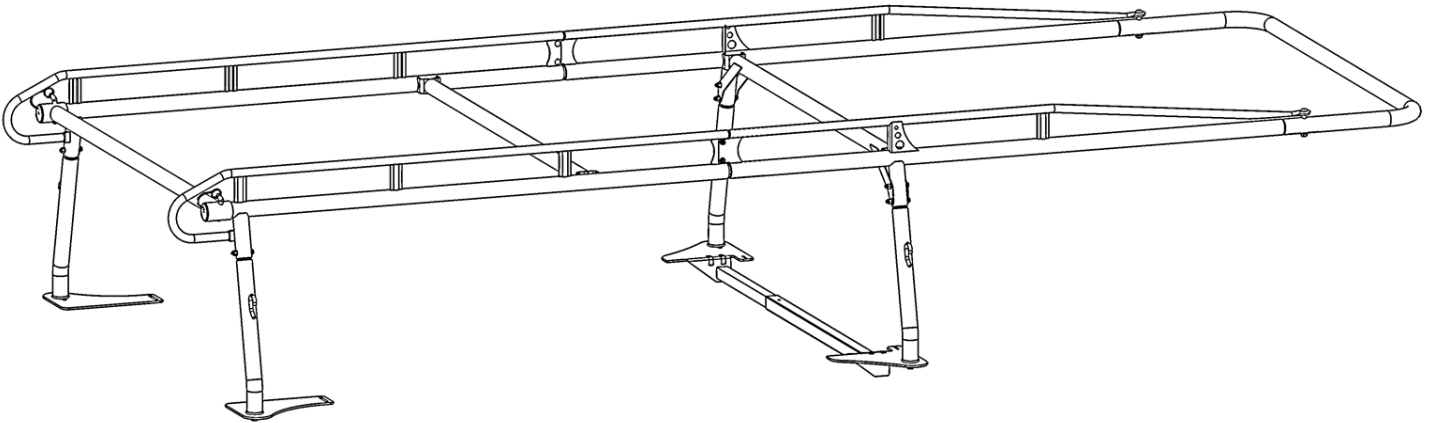

Holman
Rancho Cordova, CA 95742
800-343-7486
InstallationSupport@Holman.com

DON'T OVERLOAD YOUR VEHICLE!

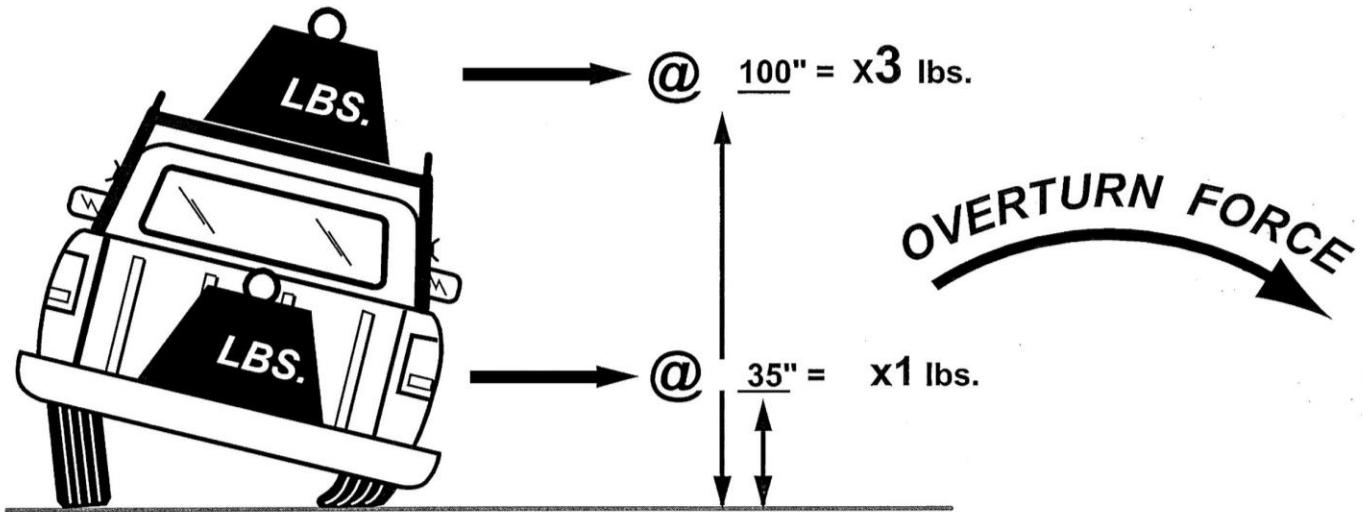

WEIGHT CARRIED ABOVE THE FLOOR OF THE TRUCK BED (E.G. ON AN OVERHEAD TRUCK RACK) WILL SIGNIFICANTLY INCREASE THE VEHICLE'S TENDENCY TO OVERTURN. ALWAYS KEEP HEAVY LOADS EVENLY DISTRIBUTED AND AS LOW AS POSSIBLE. IT IS IMPORTANT TO NOTE THAT THE HOLMAN RACK LOAD BEARING CAPACITY OF 1700 LBS. MAY BE GREATER THAN YOUR TRUCK'S GAWR OR GVWR CAPACITY, AND IS PROBABLY GREATER THAN THE WEIGHT THAT CAN BE SAFELY CARRIED OVERHEAD. RETIGHTEN ALL BOLTS AFTER FIRST USE, PERIODICALLY CHECK BOLTS FOR TIGHTNESS.

For *TECHNICAL SUPPORT* Call:

1.800.343.7486

or email: InstallationSupport@Holman.com

PLEASE READ ALL INSTRUCTIONS AND WARNINGS PRIOR TO ASSEMBLING, INSTALLING, AND USING THIS PRODUCT.

Warning



Always check for wires, fuel tanks and lines, brake lines and other important vehicle functionality items prior to drilling and installing all products.



Too much weight will greatly reduce the stability of your vehicle. Holman makes no representation or warranty as to the amount of weight your vehicle can safely carry. For guidance, we recommend that you consult the vehicle manufacturer. **AT NO TIME SHOULD THE WEIGHT OF THE VEHICLE, RACK, DRIVER, PASSENGERS AND CARGO LOADED ON A HOLMAN RACK EXCEED EITHER THE GROSS VEHICLE WEIGHT RATIO (GVWR) OR THE GROSS AXLE WEIGHT RATIO (GAWR) AS SPECIFIED BY THE VEHICLE MANUFACTURER.**



Do not use your rack with the rear cross bar removed. Removal of rear crossbar will affect structural integrity of the rack.



Secure all payloads properly for safe transportation.



A large area is required to assemble rack. Be sure to keep area clear of trip and fall hazards.

Table of Contents

Table of Contents	2
Tools Needed	3
Side Channel Parts List	3
Leg & Bar Kit Parts	3
Hardware	4
Sealant Application	7
Step 1 – Join Side Channels	7
Step 2 – Attach Front Tube.....	8
Step 3 – Attach Center Crossbar.....	8
Step 4 – Attach Front Legs and Front Crossbar	8
Step 5 – Attach Rear Legs.....	9
Step 6 – Attach Rear Crossbar	10
Step 7 – Attach Mounts	10
Step 8 – Mount Installation Preparation.....	11
Step 9 – Mount Installation	14
Step 10 – Install Shell and Rack.....	15

Tools Needed



9/16", 3/4" Box Wrenches	9/16", 1/2", 3/4" Sockets and Wrench
7/32", 5/16" Allen Wrenches*	3/8" Drill Bit and Drill
Center Punch	Hammer
Locking C-clamp	Torque Wrench

* *Included.*

Before You Begin

- Read all instructions prior to assembling or installing any Holman product.
- **Always locate your installation locations prior to performing any work.**
- **ENSURE SAFETY WHILE INSTALLING OR DRILLING INTO VEHICLE.**

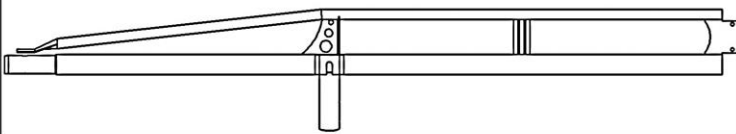
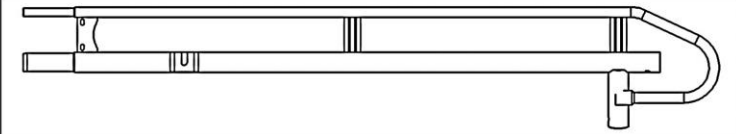
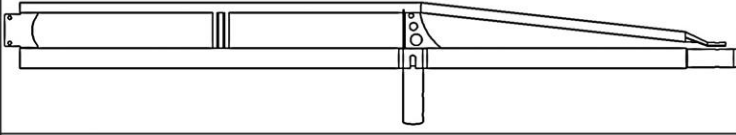

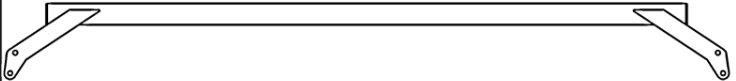

Side Channel Parts List

ITEM		MODEL / PART NUMBER	DESCRIPTION	QTY
1		04000 / 100616 06000 / 100626 06010 / 100624	SIDE CHANNEL, FRONT PS RH	1
2		04000 / 100620 06000 / 100630 06010 / 100620	SIDE CHANNEL, REAR PS RH	1
3		04000 / 100617 06000 / 100627 06010 / 100625	SIDE CHANNEL, FRONT DS LH	1
4		04000 / 100621 06000 / 100631 06010 / 100621	SIDE CHANNEL, REAR DS LH	1

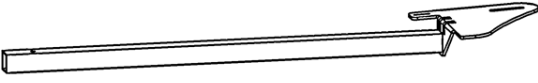
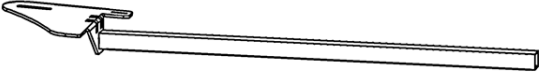
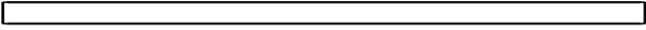
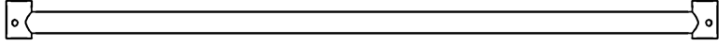

Leg & Bar Kit Parts

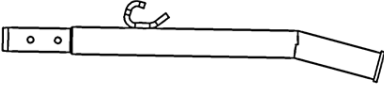
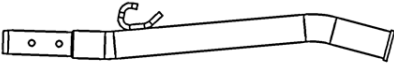
NO.	ITEM	PART NUMBER	DESCRIPTION	QTY.
1		11-00004	FRONT TUBE FS	1
2		13-00021	FRONT CROSSBAR	1



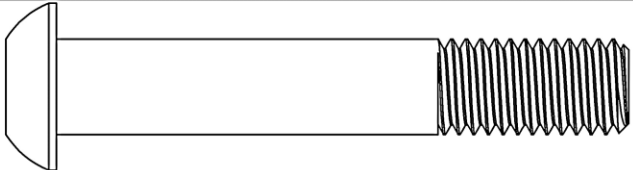
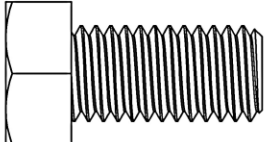
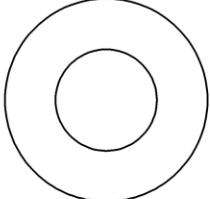
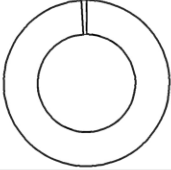

Leg & Bar Kit Parts (Continued)

NO.	ITEM	PART NUMBER	DESCRIPTION	QTY.
3		13-00843	MOUNTING PLATE WITH SUPPORT ARM, LH DS	1
4		13-00844	MOUNTING PLATE WITH SUPPORT ARM, RH PS	1
5		13-00028	CENTER CROSSBAR	1
6		13-00042	REAR CROSS BAR	1
7		11-00133	REAR MOUNTING PLATE	2
8		01130 LEG KIT: 13-00983	SD REAR LEG FOR TRUCKS W/ CAP	2
9		01130 LEG KIT: 13-00835	SD FRONT LEG, TRUCK W/ CAP	2
10		01110 LEG KIT: 13-00988	LD LEG FOR TRUCKS WITH CAP	4
11		18-00009	HARDWARE KIT	1

Hardware

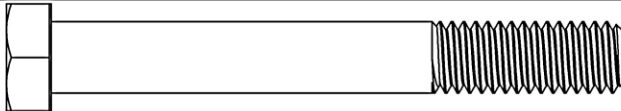
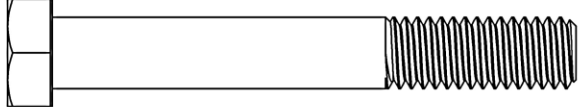
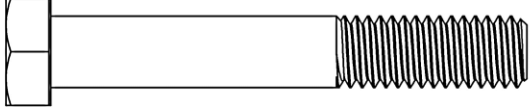
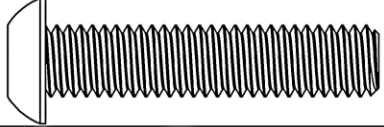
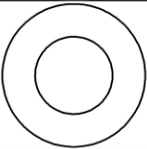
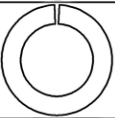
ITEM	HARDWARE TO SCALE	PART NUMBER	DESCRIPTION	QTY.
1		42KD91	1/2"-13 X 3" BUTTON HEAD CAP SCREW	2
2		11241227	1/2"-13 X 1" HEX HEAD BOLT	8
3		11541086	1/2" WASHER	10
4		1133626	1/2" LOCK WASHER	8
5		37695	1/2"-13 THIN LOCKING JAM NUT	2

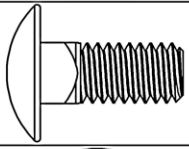
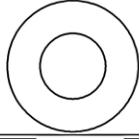
Hardware (Continued)

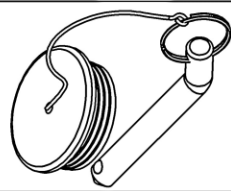
ITEM	HARDWARE TO SCALE	PART NUMBER	DESCRIPTION	QTY.
6		70115	3/8"-16 X 3" HEX HEAD BOLT	4
7		70114	3/8-16 X 2-3/4" HEX HEAD BOLT	2
8		11241202	3/8-16 X 2-1/2" HEX HEAD BOLT	1
9		94095	3/8"-16 X 1-3/4" BUTTON HEAD CAP SCREW	8
10		0159723	3/8" WASHER	30
11		0123496	3/8" SPLIT LOCK WASHER	2
12		0169791	3/8"-16 LOCK NUT	15
13		21810	5/16"-18 X 3/4" CARRIAGE BOLT	4
14		33080	5/16" WASHER	4
15		0169777	5/16"-18 NYLOC	4
16	 NOT TO SCALE	11-00112	3/8"-16 T-NUT	2
17	 NOT TO SCALE	13-00003	CAP AND LOCK PIN	2
18		26528	5/16" HEX WRENCH	1
19		26528	7/32" HEX WRENCH	1
20		-	SEALANT	1

PRO II TRUCK RACK EXPLODED VIEW

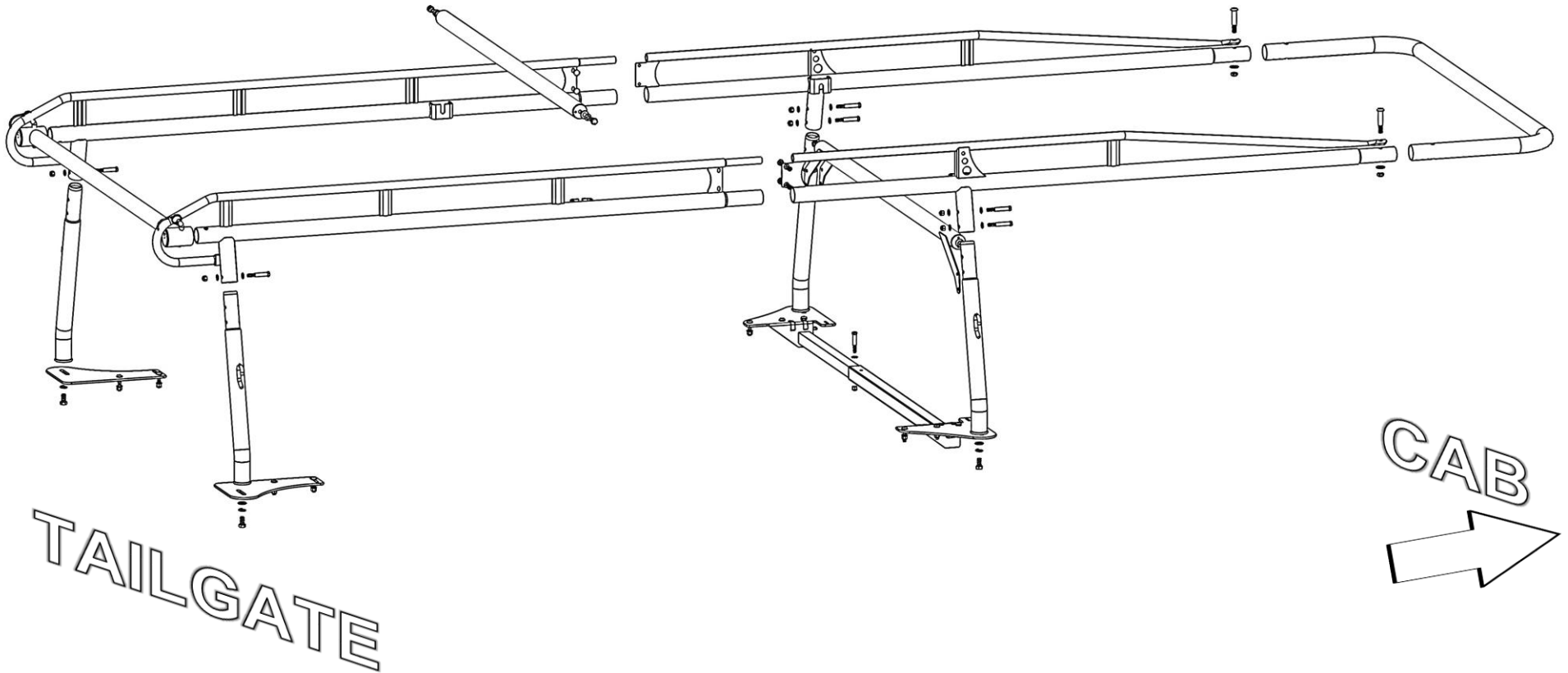

Sealant Application

- Proper sealant application is critical to preventing water penetration inside the rack.
- Apply a healthy bead of sealant around every swaged joint as shown. Improper sealing can lead to water penetration and rust on inside surfaces.
- Wipe any excess sealant off immediately with a plastic scraper or paper towel. Any smeared sealant can be rubbed off as soon as sealant dries.
- Maintain this seal throughout the life of your rack.

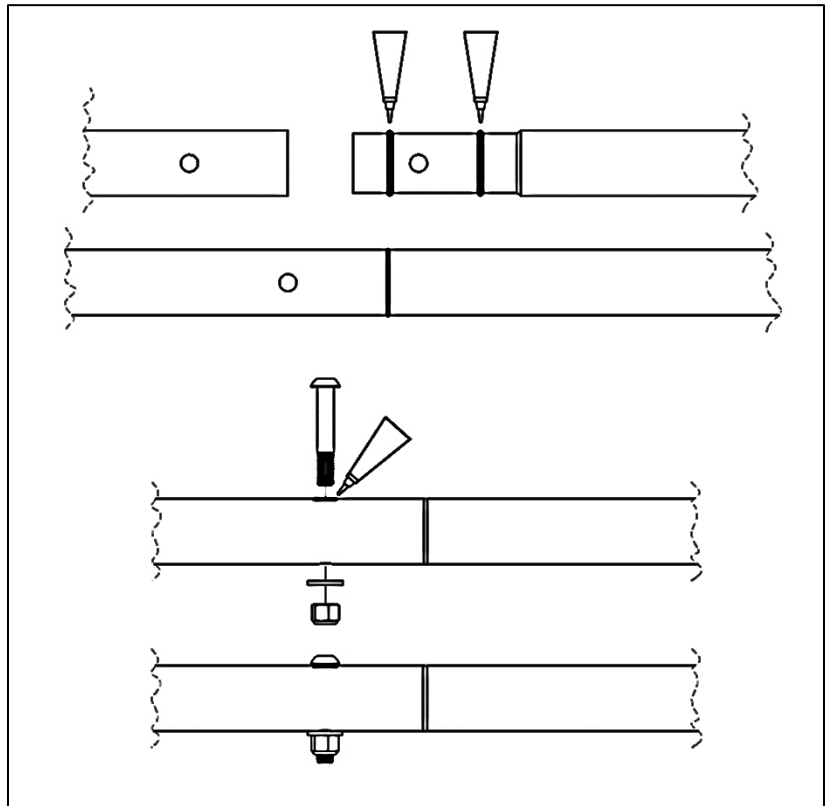

Step 1 – Join Side Channels

- Unpack side channels from box. Lay flattened box on ground and use for scratch protection while building rack.
- Open assembly hardware kit.
- **Be sure you have correct front and rear side channels paired.**
- Apply sealant to both top and bottom swage joints.
- Insert rear side-channel swaged joints into front side-channel tubes until bolt holes in splice plates align.
- Using 5/16" x 3/4" carriage bolts, 5/16" washers, and 5/16" lock nuts, securely fasten channels together.
- Remove excess sealant.
- Repeat process for opposite side.

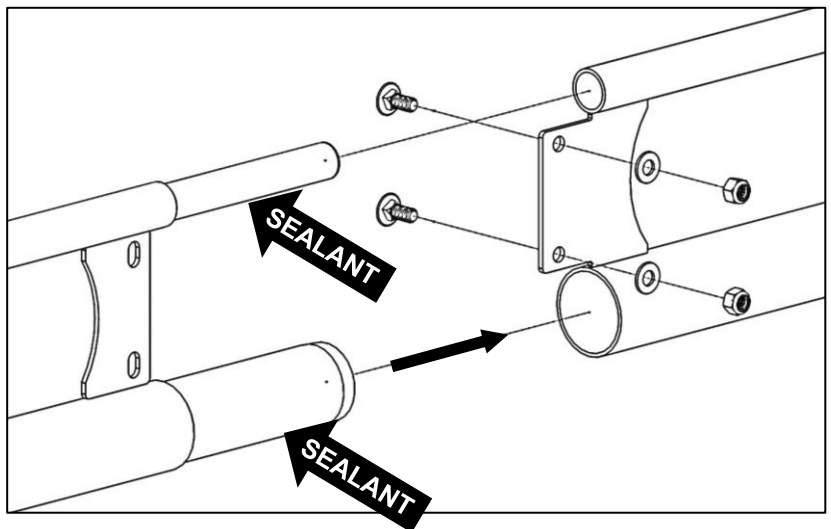

Step 2 – Attach Front Tube

- Apply sealant to front side-channel swaged joint.
- Insert front side-channel swaged joint into front tube until bolt holes in tube and side-channel align.
- Loosely fasten front tube to side channel using 1/2" x 3" partially threaded button head screw, 1/2" washer, and 1/2" lock nut.
- Remove excess sealant.
- Repeat process on opposite side.

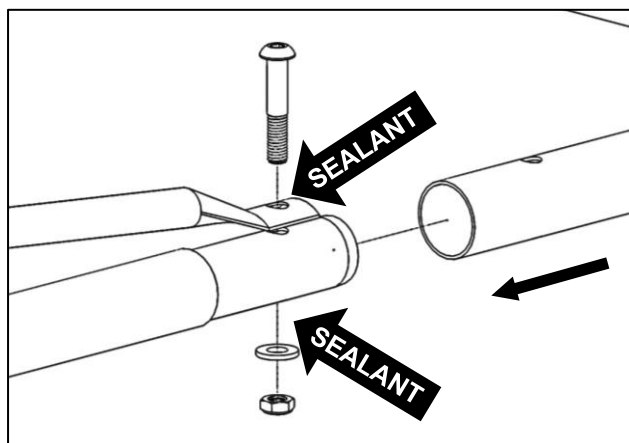

Step 3 – Attach Center Crossbar

- Thread one 1/2" x 1" hex bolt, one 1/2" lock washer, and one 1/2" washer about 1/4" deep into each end of front crossbar.
- Insert center crossbar into center crossbar bracket. **Be sure 1/2" washers are NOT between crossbar and crossbar bracket.**
- Lightly tighten 1/2" bolts on both sides.

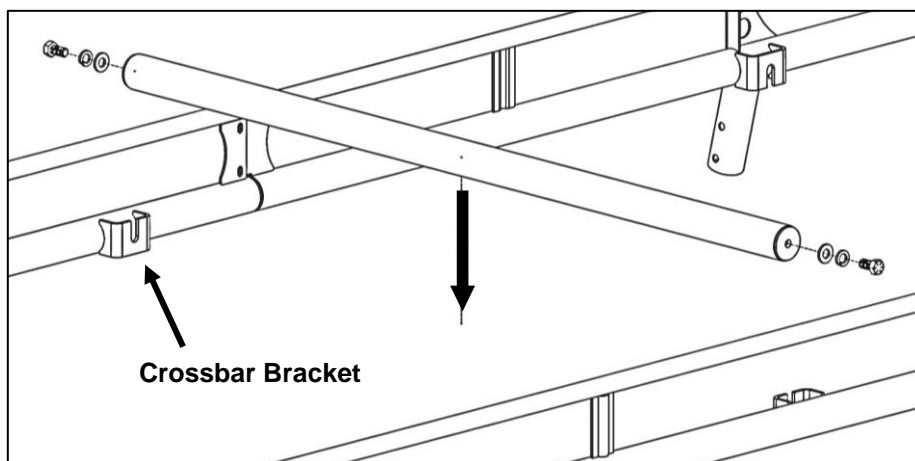

Step 4 – Attach Front Legs and Front Crossbar

- Flip rack upside down.
- Thread one 1/2" x 1" hex bolt, with one 1/2" lock washer and one 1/2" flat washer, about 1/4" deep into each end of front crossbar.
- Slide front crossbar over leg cup into crossbar bracket. **Be sure 1/2" washers are NOT between crossbar and bracket.**
- Apply sealant to swaged joint on one leg.
- Orient leg correctly with side channel, with rope hook away from center of rack, and then insert leg into leg cup until bolt holes through leg, front crossbar flange, and leg cup align.
- Remove excess sealant.

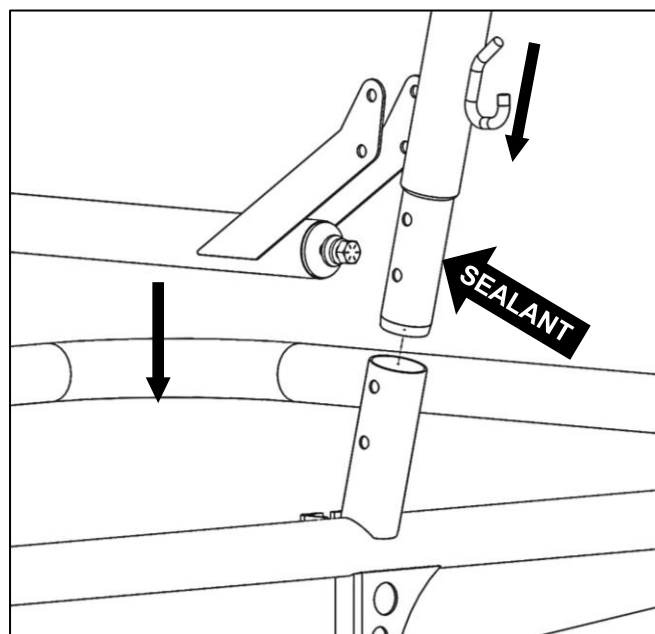

- Be sure to apply sealant between each washer and leg cup as you assemble.
- Fasten and seal leg to leg cup using two 3/8" x 3" hex head bolts, four 3/8" washers and two 3/8" lock nuts. Tighten nut to bolt to 35 ft-lb.
- Remove excess sealant.
- Repeat process on opposite side.

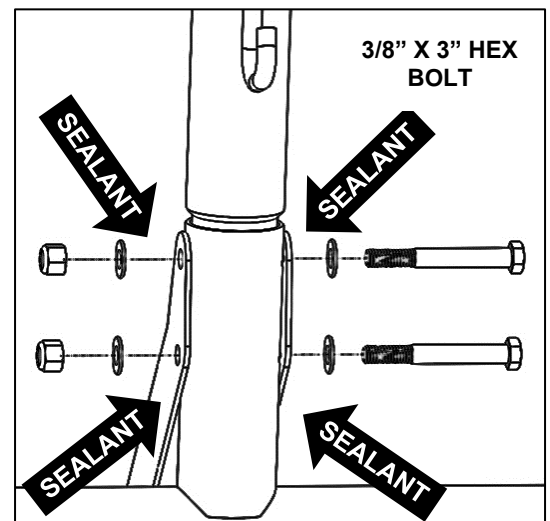

Step 5 – Attach Rear Legs

- Apply sealant to swaged joint on one leg and around holes in leg cup.
- Orient leg correctly with side channel, with rope hook away from center of rack, and then insert leg into leg cup until holes through leg and leg cup align.
- **Be sure to apply sealant around bolt between each washer and leg cup as you assemble.**
- Bolt leg to leg cup using one 3/8" x 2-3/4" hex bolt, two 3/8" washers, and one 3/8" lock nut.
- Remove excess sealant.
- Repeat process on opposite side.

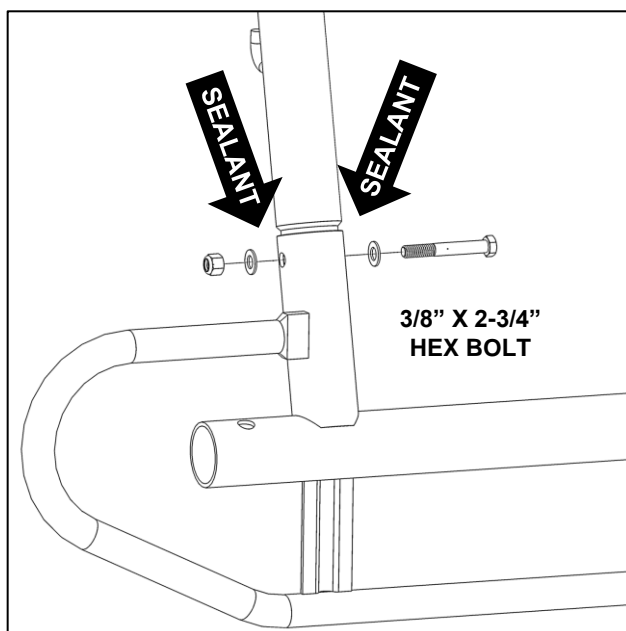
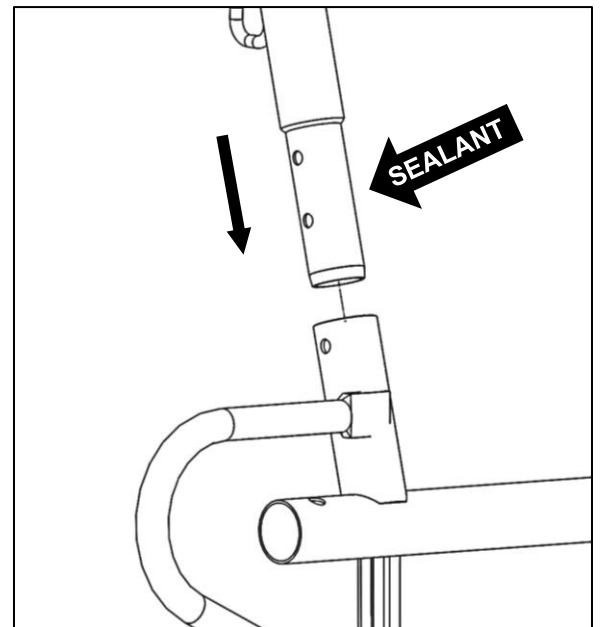

Step 6 – Attach Rear Crossbar

- Apply sealant to around black cap fastening flanges.
- Using a mallet or dead blow hammer, tap black cap into rear crossbar tubing on the side opposite the gusset welded to the rear crossbar.
- Remove excess sealant.
- Flip rack right side up.
- Slide rear crossbar ends onto rear side-channel tubes.
- Insert lock pin through holes in rear crossbar end and rear side-channel tube.

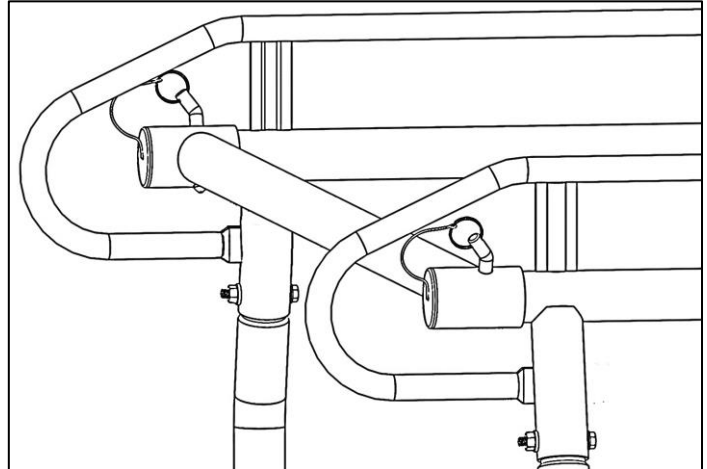
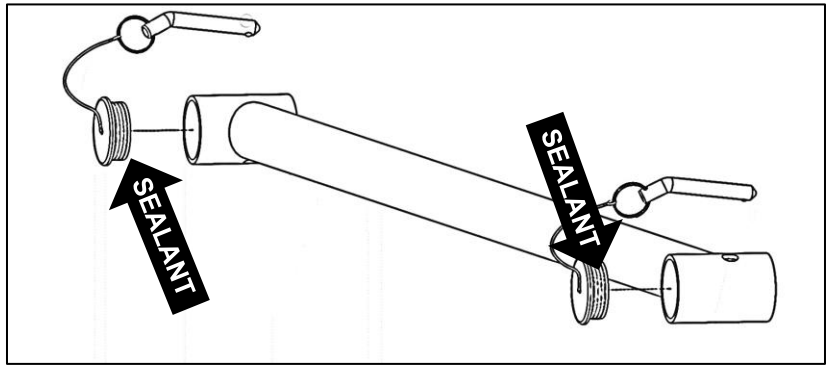

Step 7 – Attach Mounts

- Remove your camper shell from truck. Note whether or not there is a ridge on the bottom of your shell.
- Carefully insert the square tubing of the left supported mounting plate into the square tubing of the right supported mounting plate.

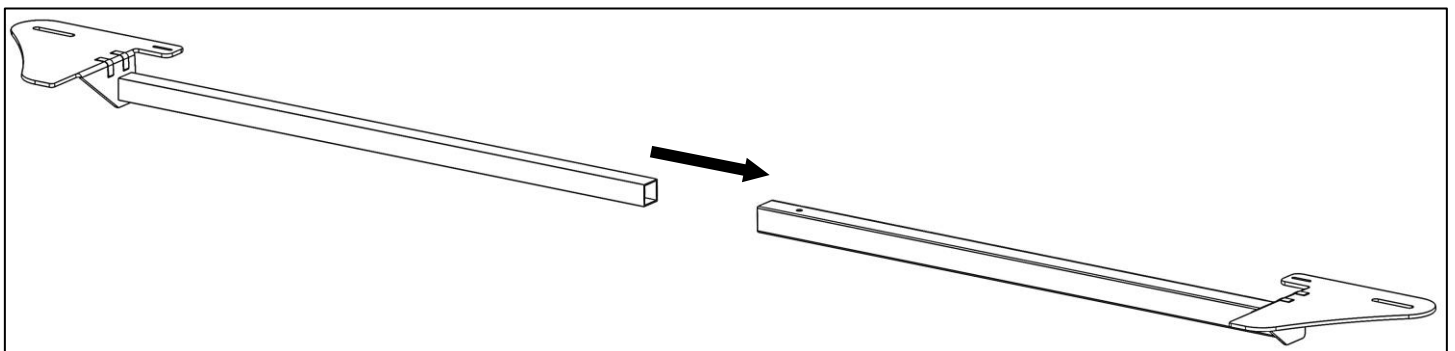
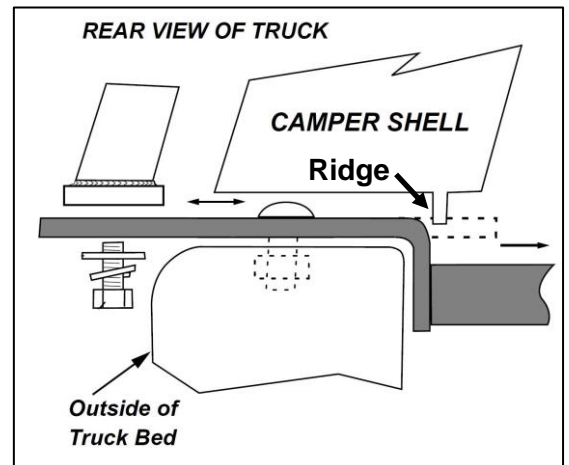

- Using 1/2" x 1" hex bolts, 1/2" lock washers, and 1/2" flat washers, bolt the supported mounting plates to the bottom of the front legs.
- Snug tighten but allow movement.

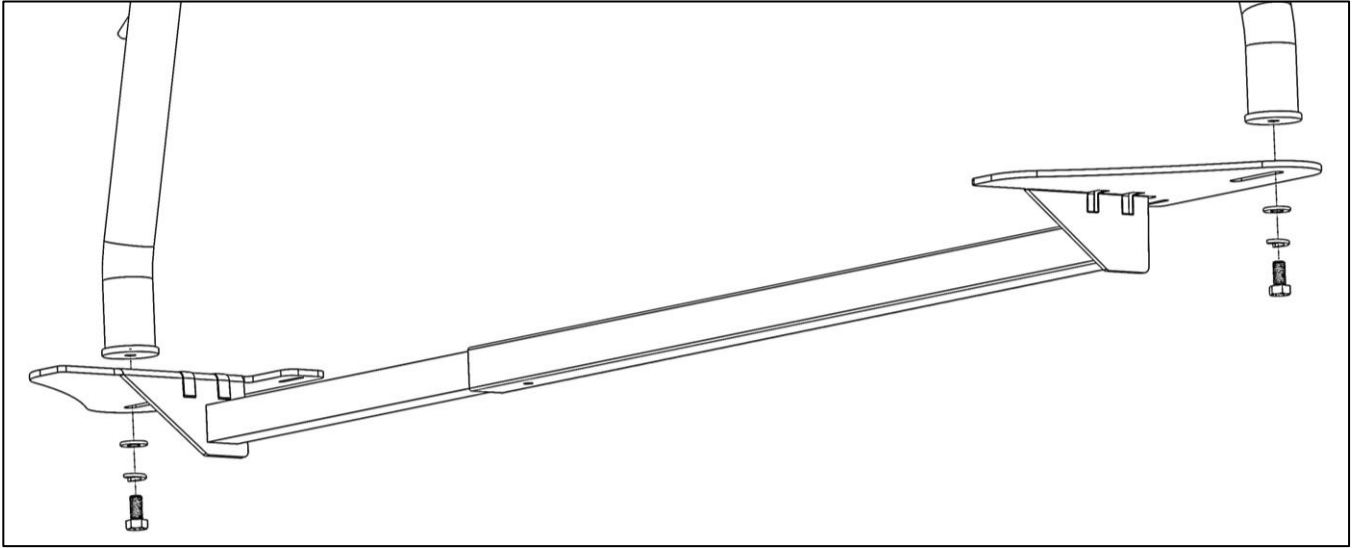

- Using 1/2" x 1" hex bolts, 1/2" lock washers, and 1/2" flat washers, bolt the rear mounting plates to the bottom of the back legs.

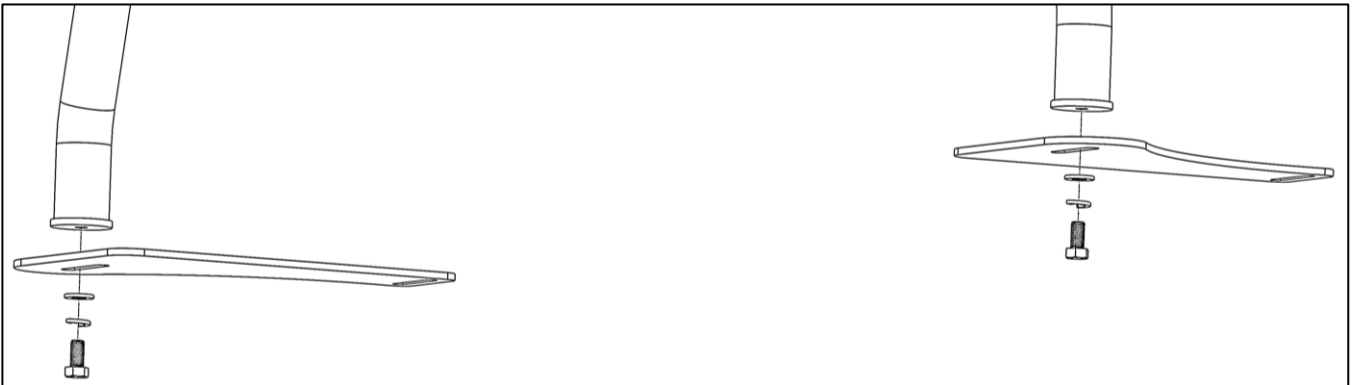

- Snug tighten but allow movement.

Step 8 – Mount Installation Preparation

- Position the rack on the truck as far forward as possible, with mounting plate tongue over the front bulkhead of the truck bed.
- Center the rack left to right on truck bed.
- Slide the front mount plates apart so that they are flush against opposite sides of the truck bed.

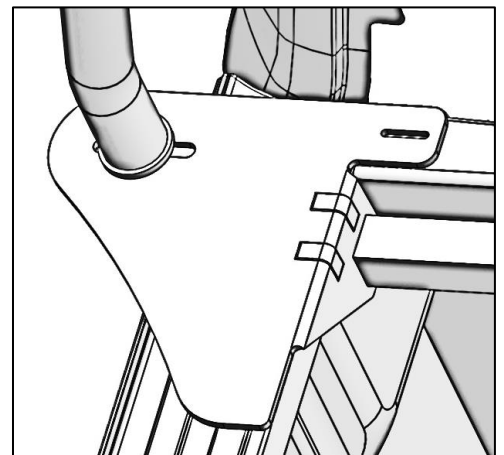

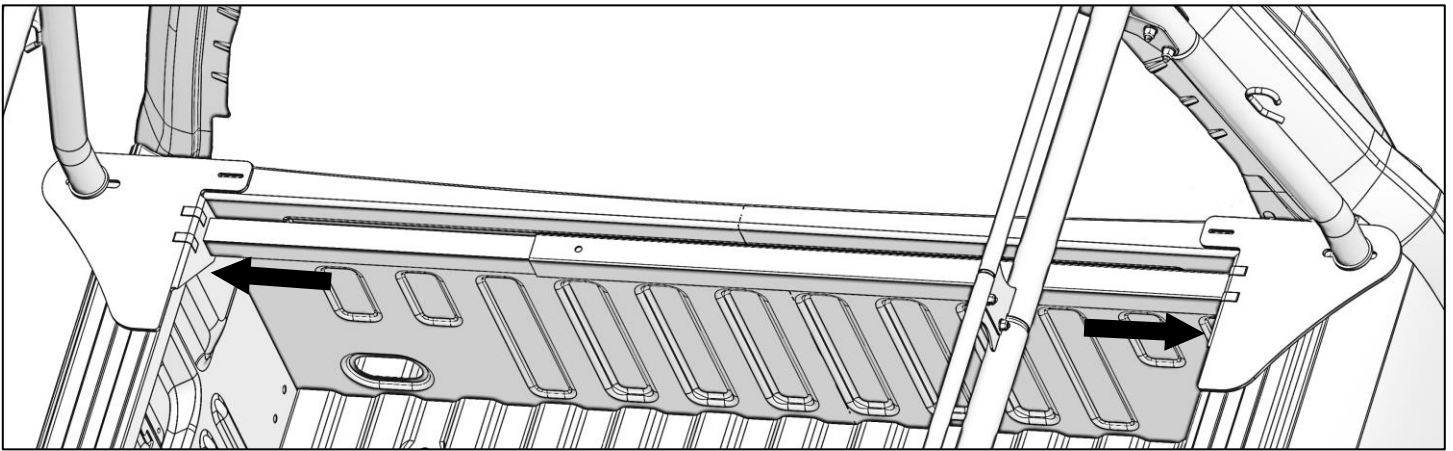

- Measure the inside dimension of the mount plates just above the support bar, and the outside dimension of the ridges (if any) on the bottom of your shell.
- It may be necessary to notch this ridge to avoid interference with the mount plates. Or you may want to notch the ridge front and back so that the mount plates can be slid in towards the center of the truck to minimize overhang.

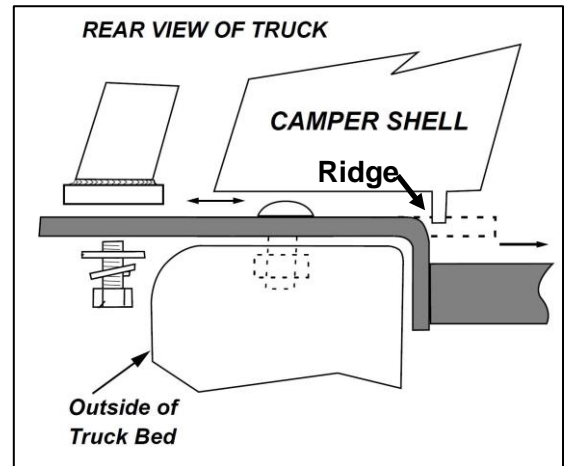

Bolt-through Mounting

- Make certain that the mount plates are square and flat horizontal with the bed rail. With the mount plates in their final position, locate and mark two optimal bolt hole locations on the top of each mount plate. The bolts should be located as far apart as possible, with clear access to the bolts, washers, and nuts underneath the truck's bedrail.

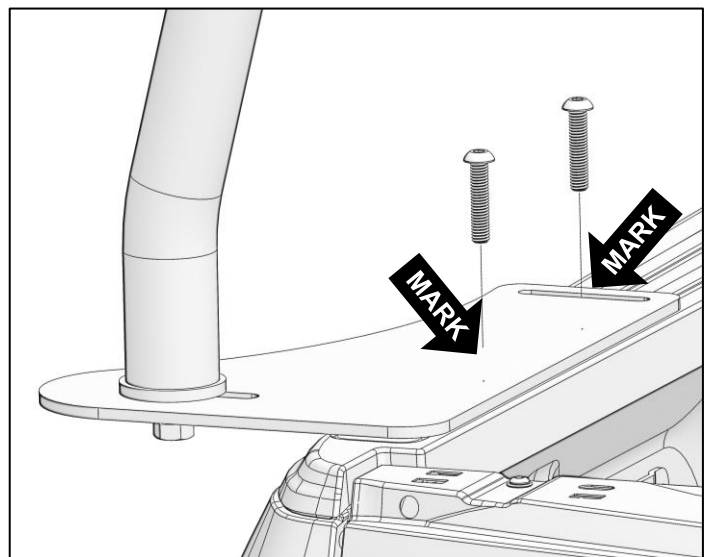
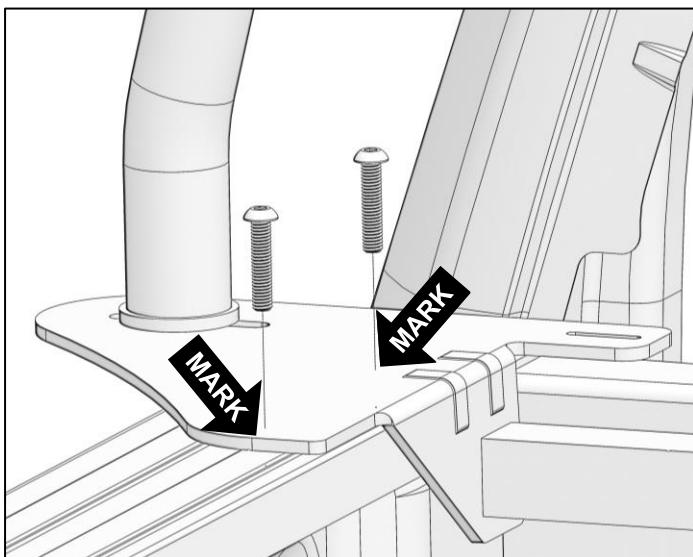

Stake Pocket Mounting

If the inside of your truck bed has a double wall and it is not possible to locate a bolt on the mounting plate nearest the leg, we recommend using our accessory **STAKE POCKET T-NUTS** to provide an **ADDITIONAL** attachment point.

- If the stake pocket is covered by plastic, remove plastic cap or cut out plastic.
- Locate center of stake pocket and mark location on top of mounting plate.

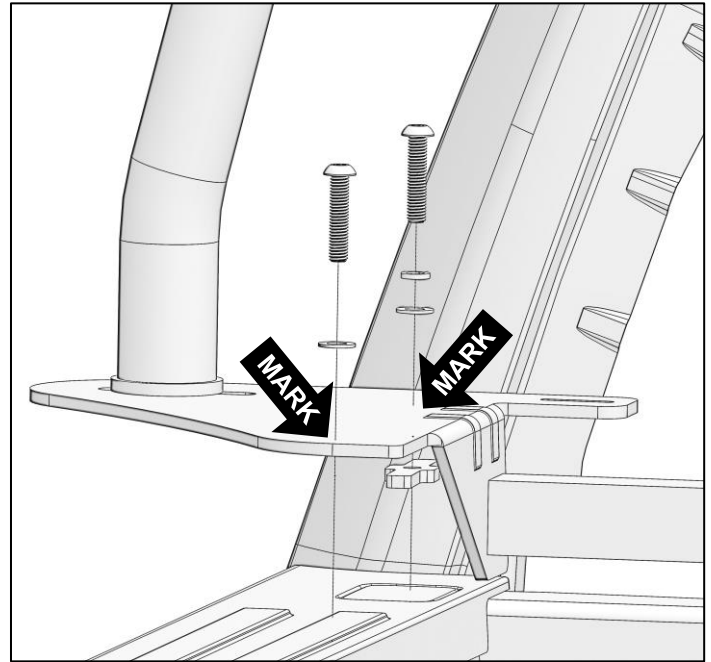

- With the front mount plates in position, mark the through bolt hole in the inner support arm.

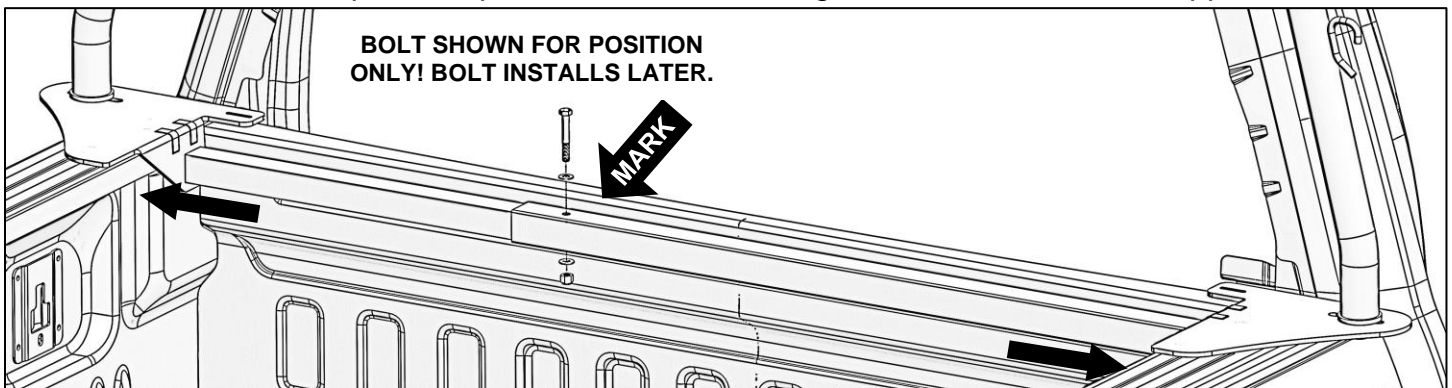

- Remove rack from the truck, and remove the rear mounting plates and front support arm from rack.
- Punch hole centers in the locations that you have marked.
- **CHECK TWICE - DRILL ONCE!**
- Drill 3/8" holes in the mount plates and the inner support arm.
- Bolt the support arms together using a 3/8" x 2-1/2" hex bolt, two 3/8" flat washers, and a 3/8" lock nut.

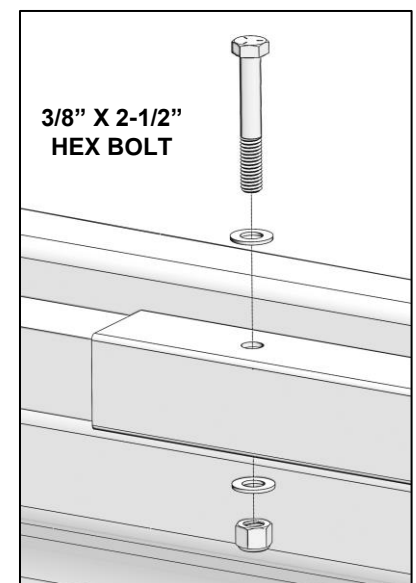

Step 9 – Mount Installation

- Set the mount plates back on the truck, in exactly the same location that they were before. Make certain each mount plate is square with the bed rail and dead horizontal. We recommend that you clamp each mount plate in position before drilling through the truck's bed rail.
- **CHECK TWICE - DRILL ONCE!**
- Drill through the bed using the holes in mount plates as guides.
- **If using the stake pocket installation**, screw the 3/8" x 1-3/4" cap screw, with 3/8" lock washer and 3/8" flat washer, through drilled hole and then into T-nut.
- Insert the 3/8" t-nut into the stake pocket hole.
- With the front foot at the correct distance, snug tighten the 3/8" x 2-1/2" button head screw until the t-nut is bound beneath the metal stake pocket hole.

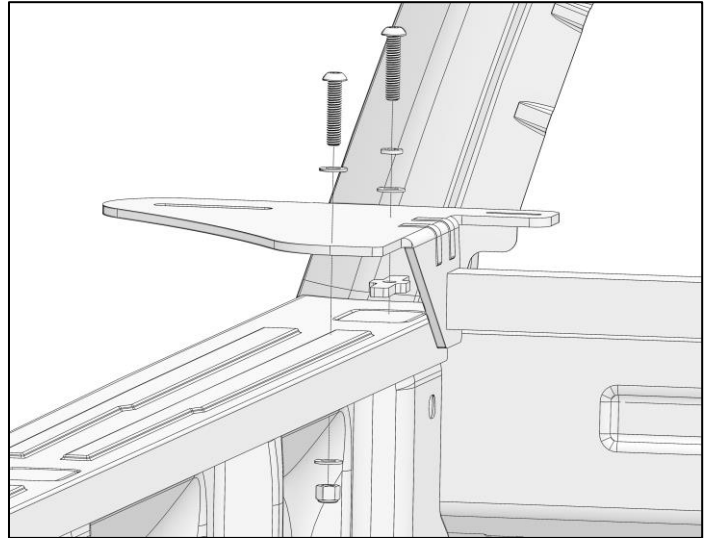

- Using 3/8" x 1-3/4" cap screws, 3/8" flat washers, and 3/8" lock nuts, bolt the mounting plates to the bed.
- Snug tighten but allow for movement. **DO NOT TIGHTEN** until all mounting bolts have been installed. It may be helpful to set the rack on the mounts to verify fitment before tightening hardware.

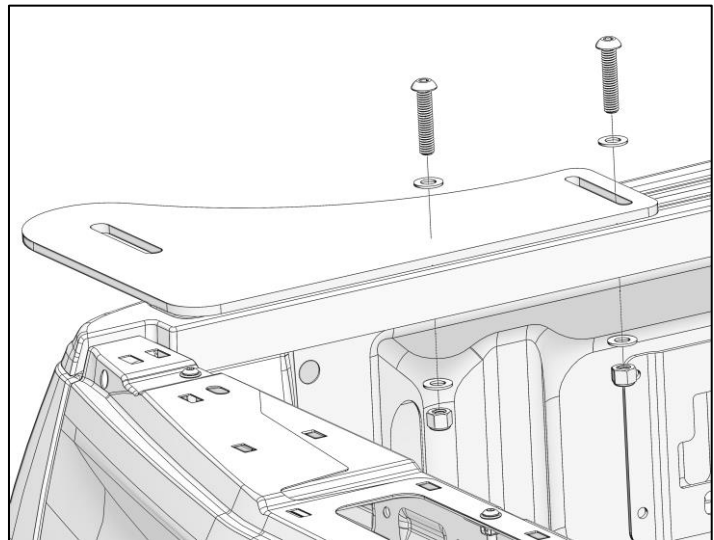
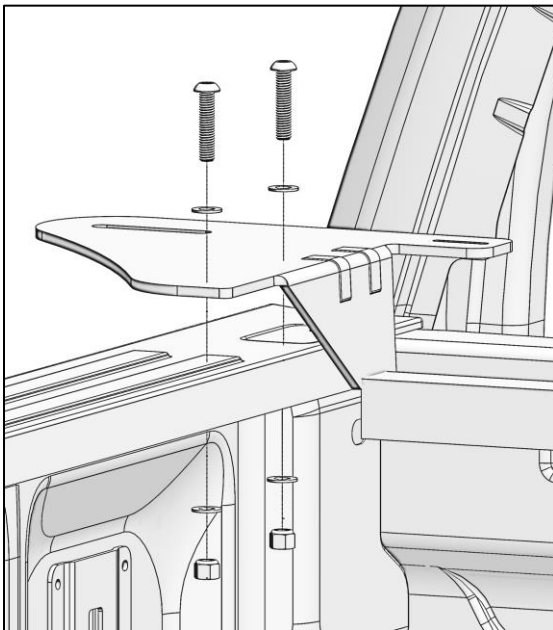

- **Once mounts in correct position, TIGHTEN ALL MOUNTING HARDWARE.**

Step 10 – Install Shell and Rack

- Apply adhesive foam tape (NOT INCLUDED) between the footplates and camper shell, along the bed rail, and along the top of the bulkhead, to seal the gaps.
- Attach the camper shell to the truck.
- Place the rack on the mount plates and center.
- Using 1/2" x 1" hex bolts, 1/2" lock washers, and 1/2" flat washers, bolt the rack to the mounting plates.

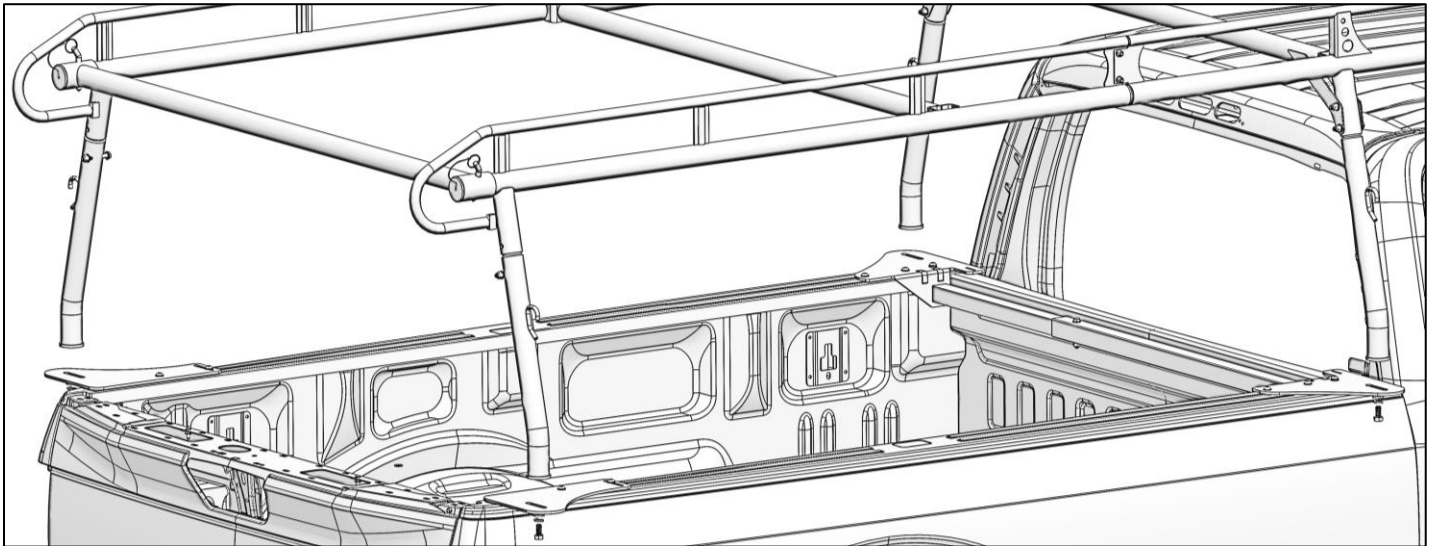

- Adjust each rear leg slightly side to side to ensure that the lock pins in the removable rear bar slide in and out easily.
- Tighten up ALL bolts.
- Verify rear crossbar lock-pin pulls in and out easily. If necessary, loosen rear leg hardware, slide rear crossbar hard left then right about 10 times to get lock-pins to seat properly, and then tighten hardware.

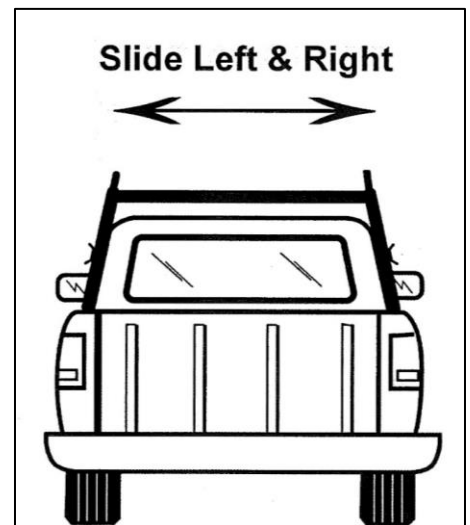

GO BACK AND TIGHTEN ALL HARDWARE.

If cordless impact wrench was used to assemble, tighten all hardware using wrenches and sockets.

INSTALLATION AND ASSEMBLY ARE COMPLETE.