

# Holman

---

## Instruction Guide

### 12908

---

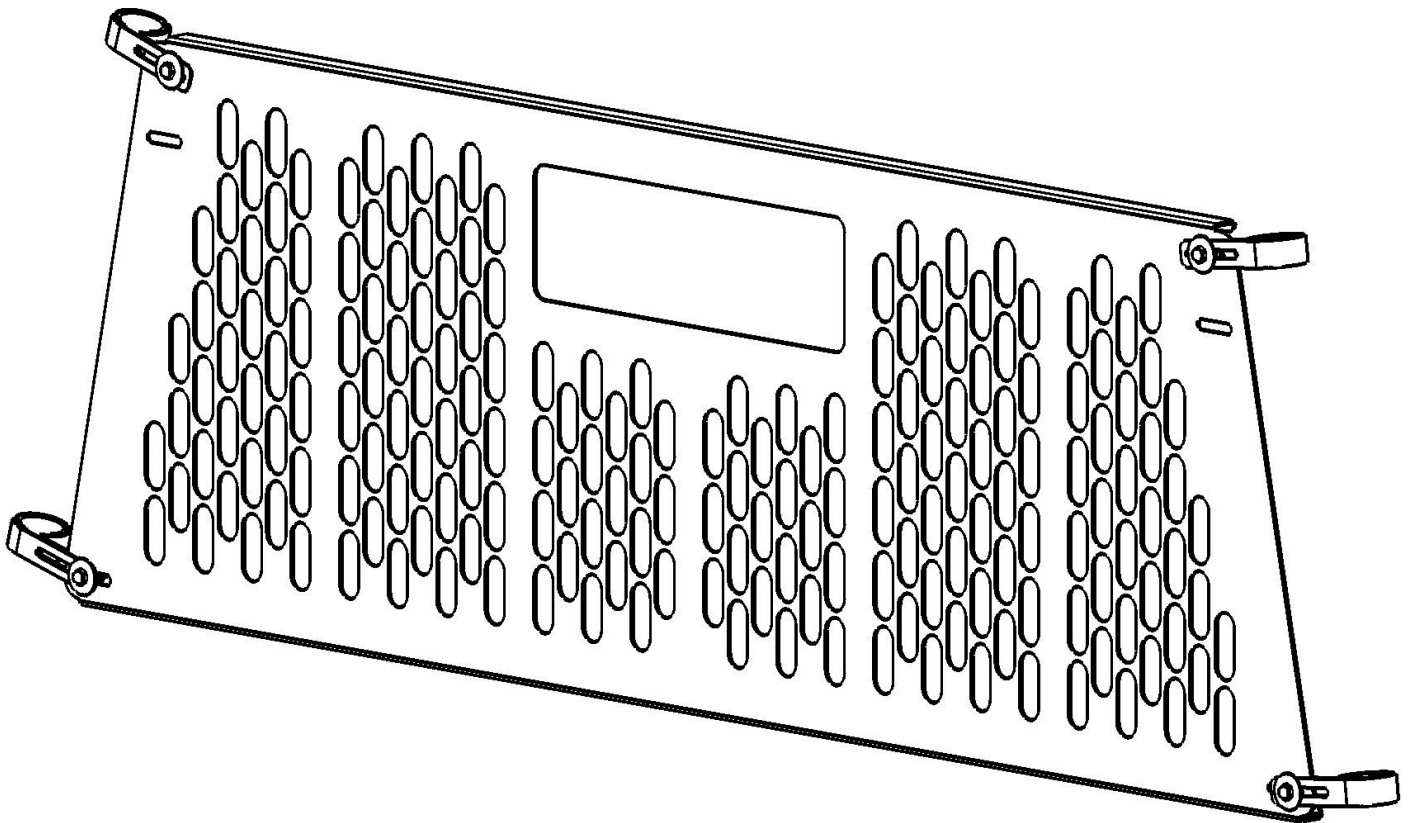

---

Holman  
Rancho Cordova, CA 95742  
800-343-7486  
[InstallationSupport@Holman.com](mailto:InstallationSupport@Holman.com)

## PLEASE READ ALL INSTRUCTIONS AND WARNINGS PRIOR TO ASSEMBLING, INSTALLING, AND USING THIS PRODUCT.

### Warning



Always check for wires, fuel tanks and lines, brake lines and other important vehicle functionality items prior to drilling and installing all products.

### Tools Needed

1/2" Socket and Socket Wrench	1/2" Box Wrench
-------------------------------	-----------------





### Table of Contents

Before You Begin .....	1
Parts .....	1
Hardware .....	2
Step 1A – Prepare Tube Clamps - 2" Diameter Leg .....	2
Step 1B – Prepare Tube Clamps - 1-5/8" Diameter Leg .....	2
Step 2 – Install Window Guard .....	3

### Before You Begin

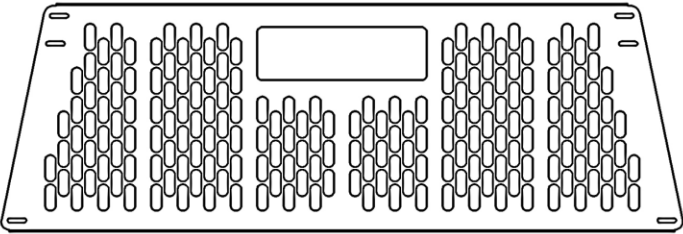
- Read all instructions prior to assembling or installing any Holman product.
- **Always locate your installation locations prior to performing any work.**

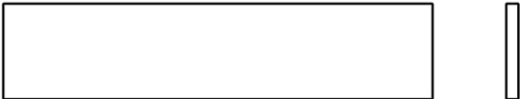
### Parts

NO.	ITEM	PART NUMBER	DESCRIPTION	QTY.
1		101491	WINDOW GUARD F/S LIGHT DUTY 22"	1
2		12-00191	2" TUBE CLAMP	4
3		12-00191A	RUBBER PAD, 1" W X 4-1/2" L, 1/8" THICK	4
4		101805	RUBBER PAD, 1" W X 5" L, 1/32" THICK	4
5		18-00160	HARDWARE KIT	1

## Hardware

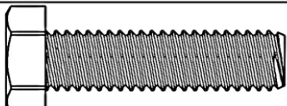
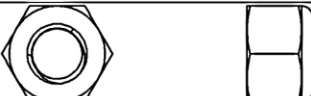
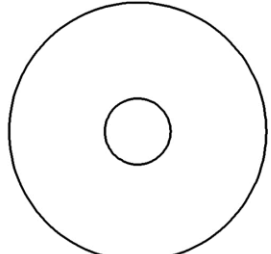
ITEM	HARDWARE TO SCALE	PART NUMBER	DESCRIPTION	QTY.
1		11241180	5/16-18 X 1-1/4" HEX HEAD BOLT	4
2		37521	5/16"-18 LOCK NUT	4
3		0189947	5/16" FENDER WASHER	8

### Step 1A – Prepare Tube Clamps - 2" Diameter Leg

This step assumes installation to rack with 2" diameter legs.

- Dry wipe clean inside diameter of two tube clamps.
- Remove plastic backing from a 1/32" thick tape strip and install strip onto inside diameter of tube clamp.
- Repeat for remaining tube clamps.

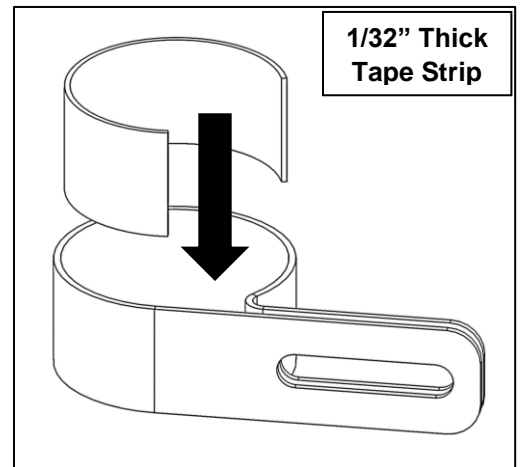

### Step 1B – Prepare Tube Clamps - 1-5/8" Diameter Leg

This step assumes installation to rack with 1-5/8" diameter legs.

- Dry wipe clean inside diameter of remaining tube clamps.
- Remove plastic backing from a 1/32" thick rubber pad strip.
- Install a rubber pad strip onto inside diameter of tube clamp.
- Dry wipe clean inside diameter of rubber pad strip.
- Remove plastic backing from a 1/8" thick rubber pad strip and install strip onto inside diameter of previously installed 1/32" thick rubber pad strip.
- Repeat for remaining tube clamps.

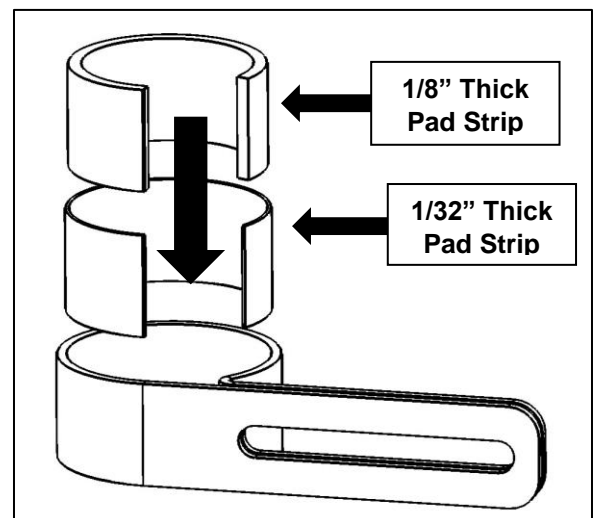

## **Step 2 – Install Window Guard**

**Note:** The following images show 2” diameter tubing installation.

- Place tube clamps around the front legs of rack with flat end of flange towards the front.
- Put and hold window guard into position with flat face facing towards the rear.

**NOTE:** There are two top mounting slots available to mount topmost tube clamp. Applicable slot will depend on rack size and desired window guard placement.

- For each tube clamp, use a 5/16” x 1-1/4” hex bolts, two 5/16” fender washers, and a 5/16” lock nut to loosely bolt through the tube clamp, then the window guard.

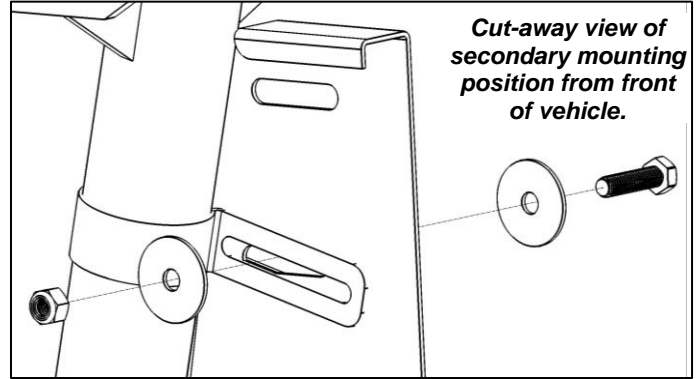
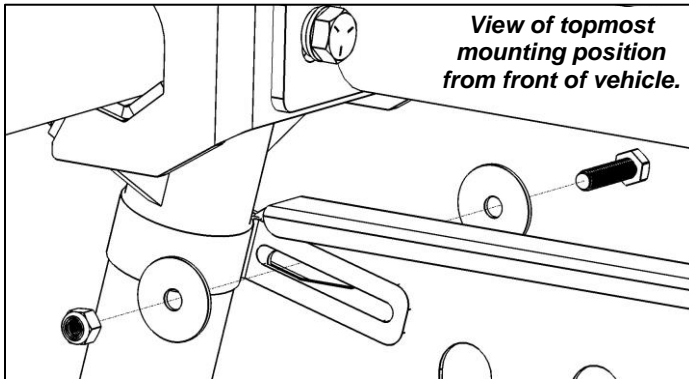

- Snug tighten hardware but allow for movement of the window guard.
- Holding the window guard level and centered to vehicle, tighten hardware.

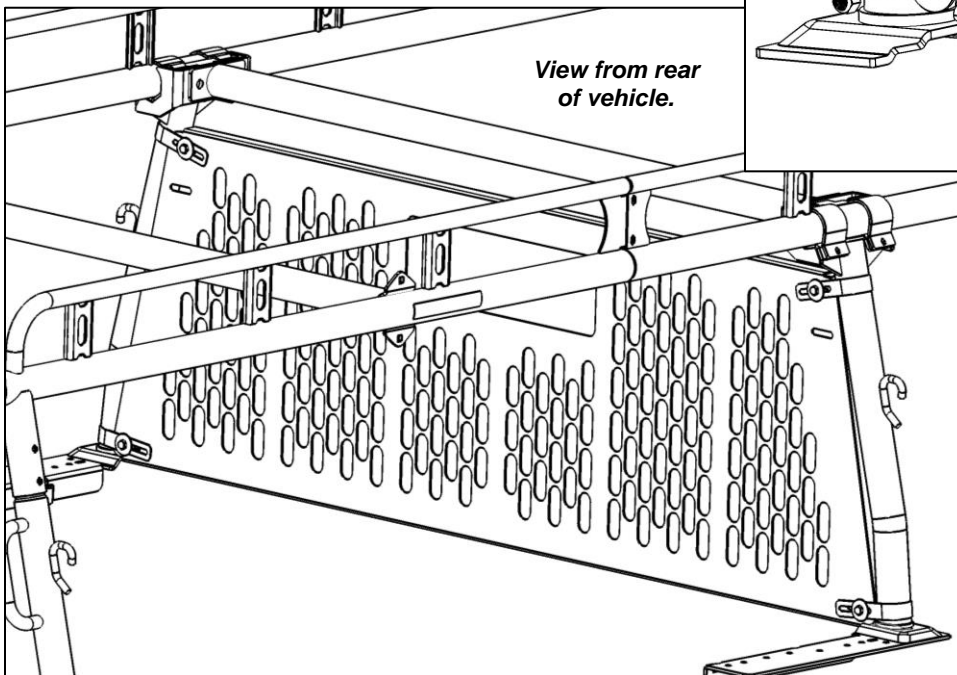
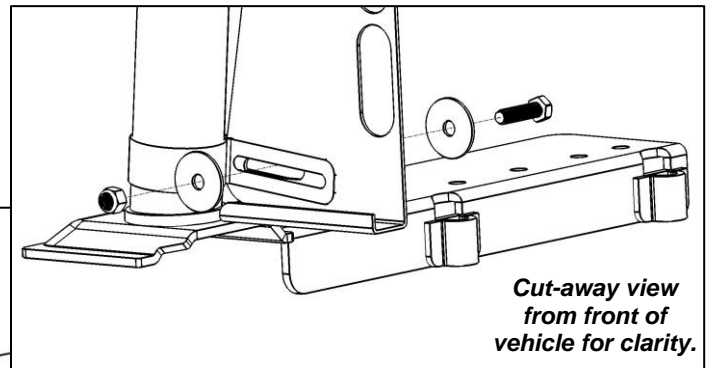

**GO BACK AND TIGHTEN ALL HARDWARE.**

**INSTALLATION AND ASSEMBLY ARE COMPLETE.**