

Holman

Instruction Guide

31080C

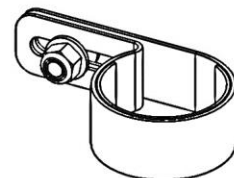
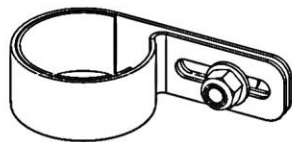
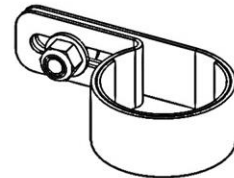
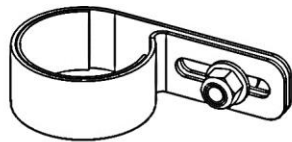

Holman
Rancho Cordova, CA 95742
800-343-7486
InstallationSupport@Holman.com

PLEASE READ ALL INSTRUCTIONS AND WARNINGS PRIOR TO ASSEMBLING, INSTALLING, AND USING THIS PRODUCT.

Warning



Always check for wires, fuel tanks and lines, brake lines and other important vehicle functionality items prior to drilling and installing all products.

Tools Needed

1/2" Socket and Socket Wrench	1/2" Box Wrench
-------------------------------	-----------------

Table of Contents

Before You Begin 1

Parts 1

Hardware 2



Step 1 – Prepare Tube Clamps (1-5/8" Tube Rack Only) 2

Step 2 – Install Window Guard 3

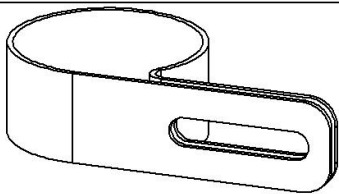

Before You Begin

- Read all instructions prior to assembling or installing any Holman product.
- **Always locate your installation locations prior to performing any work.**

Parts

NO.	ITEM	PART NUMBER	DESCRIPTION	QTY.
1		12-00191	2" TUBE CLAMP	4
2	 * NOT TO SCALE	12-00191A	SPACER PAD, 1"W X 4.25"L	4
3		18-00160	ECONO WINDOW GUARD HARDWARE KIT	1

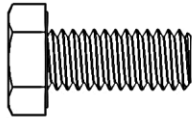
Hardware

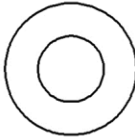
ITEM	HARDWARE TO SCALE	PART NUMBER	DESCRIPTION	QTY.
1		11241178	5/16-18 X 3/4" HEX HEAD BOLT	4
2		0169777	5/16"-18 NYLOC	4
3		33080	5/16" WASHER	8

Step 1 – Prepare Tube Clamps (1-5/8" Diameter Tubing Only)

If using 1-5/8" Diameter Tubing, the spacer strips must be applied to ensure a snug fit to rack.

- Dry wipe clean inside diameter of tube clamps.
- Remove backing from a spacer strip.
- Stick backing to inside of tube clamp.
- Repeat for remaining tube clamps.

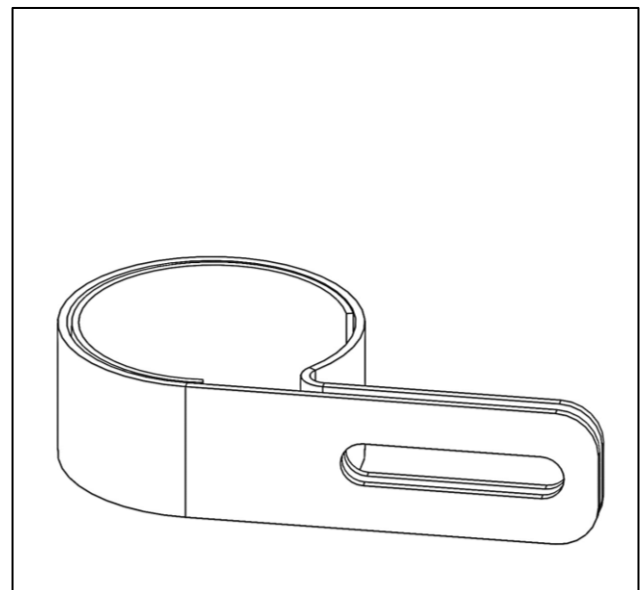
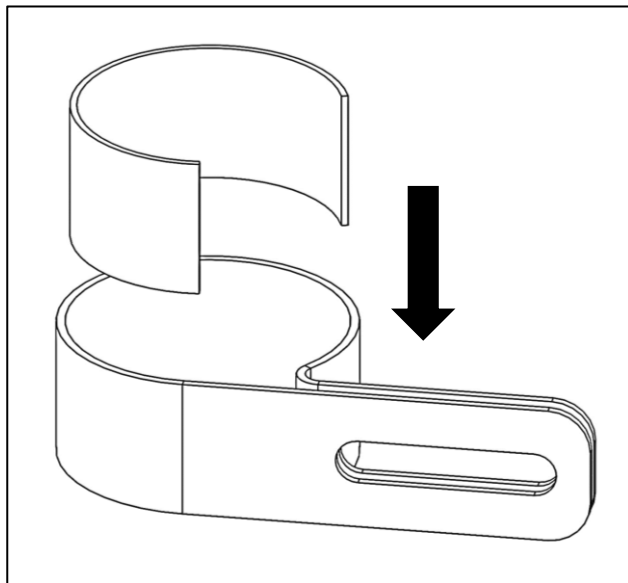

Step 2 – Install Window Guard

- Place tube clamps around the front legs of rack with flat end of flange towards the rear.
- Put and hold window guard into position with flat face facing towards the rear.
- For each tube clamp, use a 5/16" x 3/4" hex bolts, two 5/16" flat washers, and a 5/16" lock nut to loosely bolt through the tube clamp, then the window guard.
- Snug tighten hardware but allow for movement of the window guard.
- Holding the window guard level and centered to vehicle, tighten hardware.

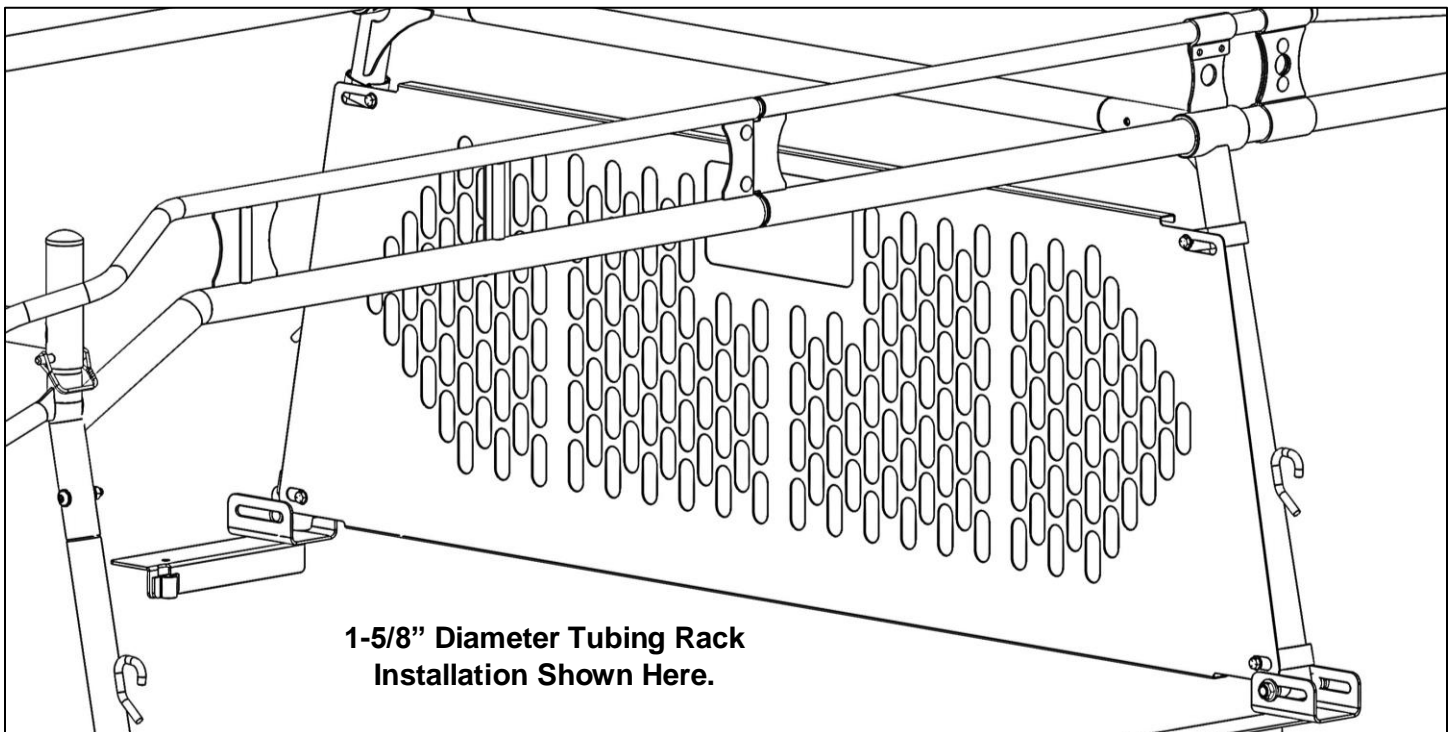
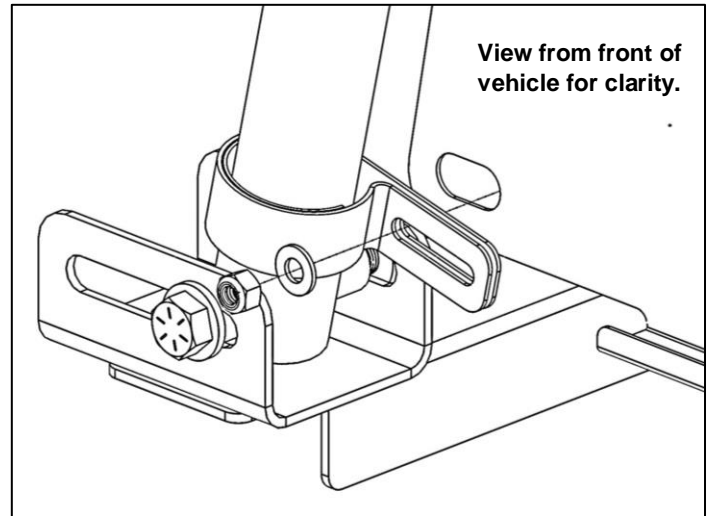
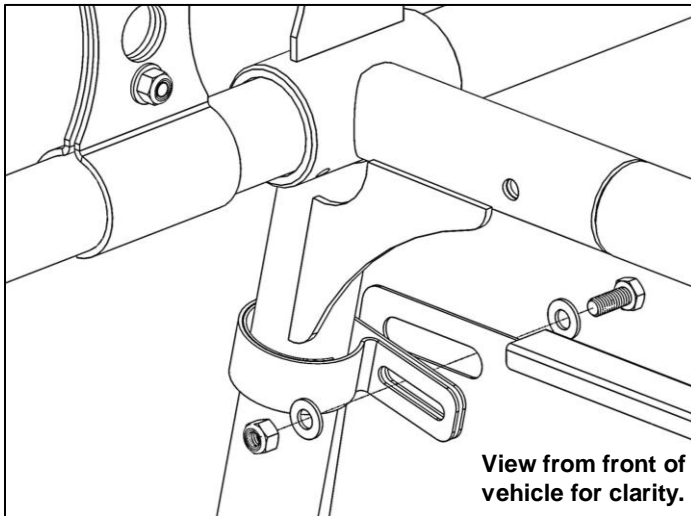

GO BACK AND TIGHTEN ALL HARDWARE.
INSTALLATION AND ASSEMBLY ARE COMPLETE.