

Holman

Instruction Guide 40150

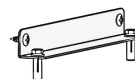
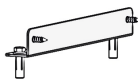
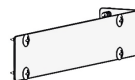
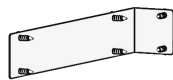
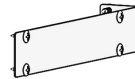
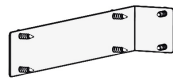
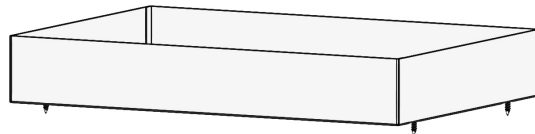

Holman
Rancho Cordova, CA 95742
800-343-7486
InstallationSupport@Holman.com

20210624R2

DATE: _____

PLEASE READ ALL INSTRUCTIONS AND WARNINGS PRIOR TO ASSEMBLING, INSTALLING, AND USING THIS PRODUCT

Warning



Always check for wires, fuel tanks and lines, brake lines and other important vehicle functionality items prior to drilling and installing all products.

Tools Needed

Phillips Driver	25/64" Drill Bit
7/16" Socket and Wrench	7/16", 9/16" Box Wrench
Drill Bit Stop Collar	Drill
Plus Nut Installation Tool (P9902)*	

* Sold Separately.

Table of Contents

Parts	3
Hardware	3
Step 1 – Bolt Drawer Units Together	4
Step 2 – Assemble Top Tray	5
Step 3 – Assemble Floor Mounts	5
Step 4 – Installation into Vehicle.....	6



Before You Begin

- Read all instructions
- **Ensure safety prior to drilling. USE A DRILL STOP.**
- **Plus Nut Installation Tool Kit (P9902) is not included and must be purchased separately.**

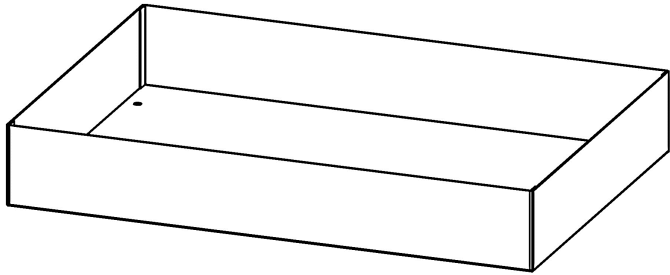
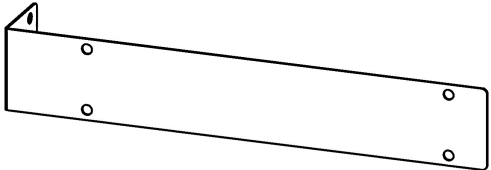
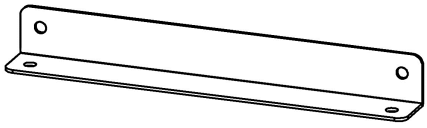
Parts

ITEM NO.		PART NUMBER	DESCRIPTION	QTY.
A		40150-00-001	Top Tray	1
B		40150-00-002	Connector Bracket	4
C		40150-00-003	Floor Mount	2
		18-40150-R1	Hardware	1

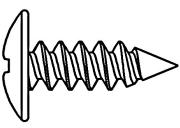
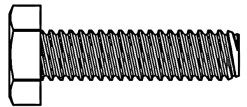
Hardware

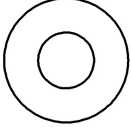
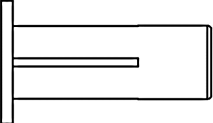
ITEM NO.	HARDWARE TO SCALE	PART NUMBER	DESCRIPTION	QTY.
1		94306A313	#14 x 3/4" Truss Head Sheet Metal Screw	32
2		92865A544	1/4"-20 x 1" Hex Head	4
3		90126A029	1/4" Lock Washer	4
4		90126A029	1/4" Flat Washer	4
5			1/4"-20 Plus Nut	4

Step 1 – Bolt Drawer Units Together

- Decide if two or three drawer units will be stacked.
- Stack two drawer units on top of one another.
- Place connector brackets so that the holes from each drawer unit align with the holes in each bracket. Place the long end of the bracket along the side of the drawer unit and the short end at the rear.
- Screw the bracket into place using #14 screws.
- Tighten and repeat at all locations.

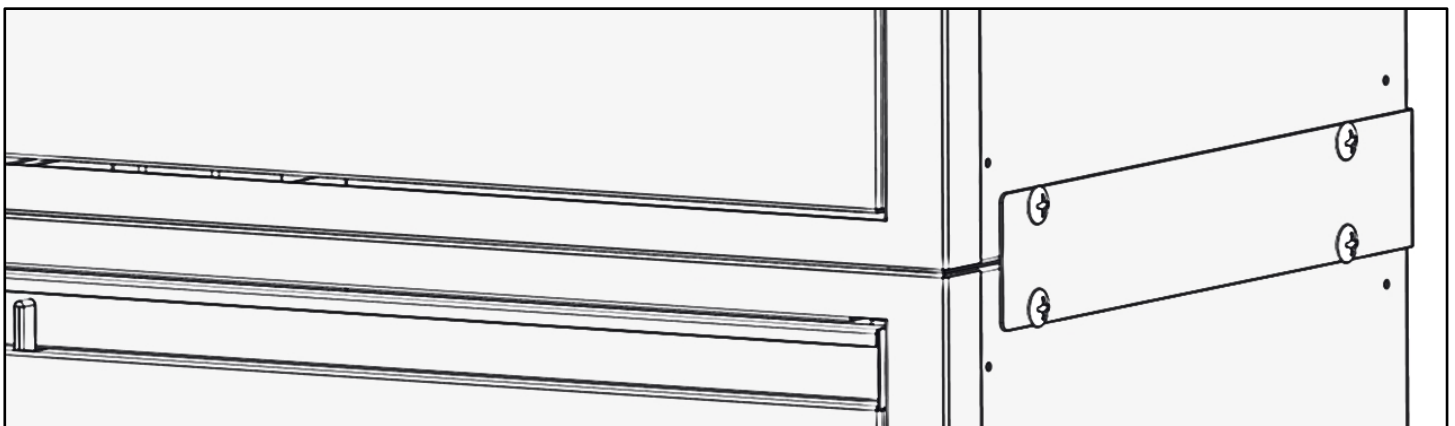
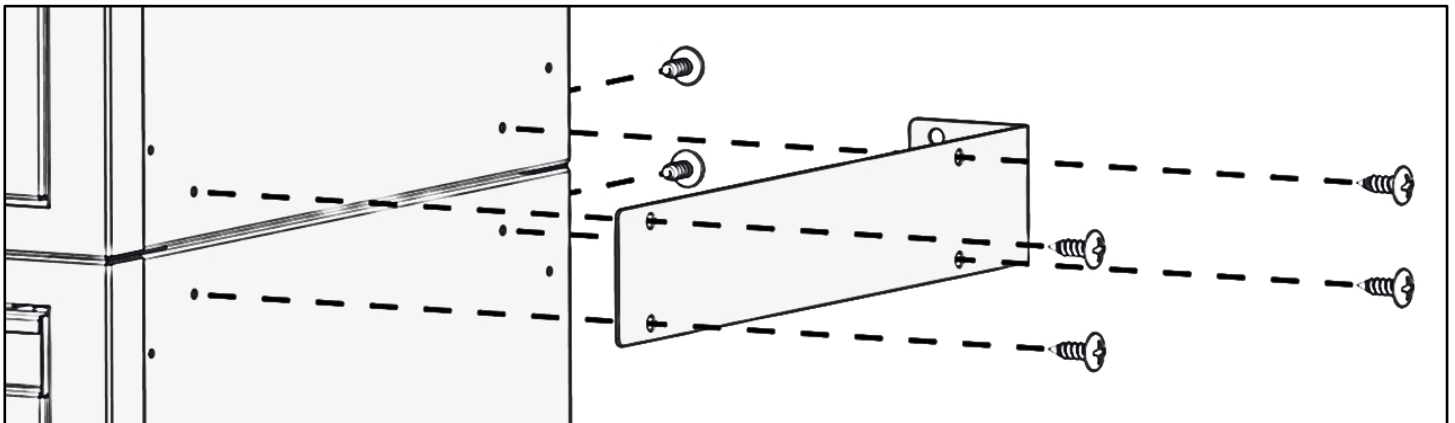
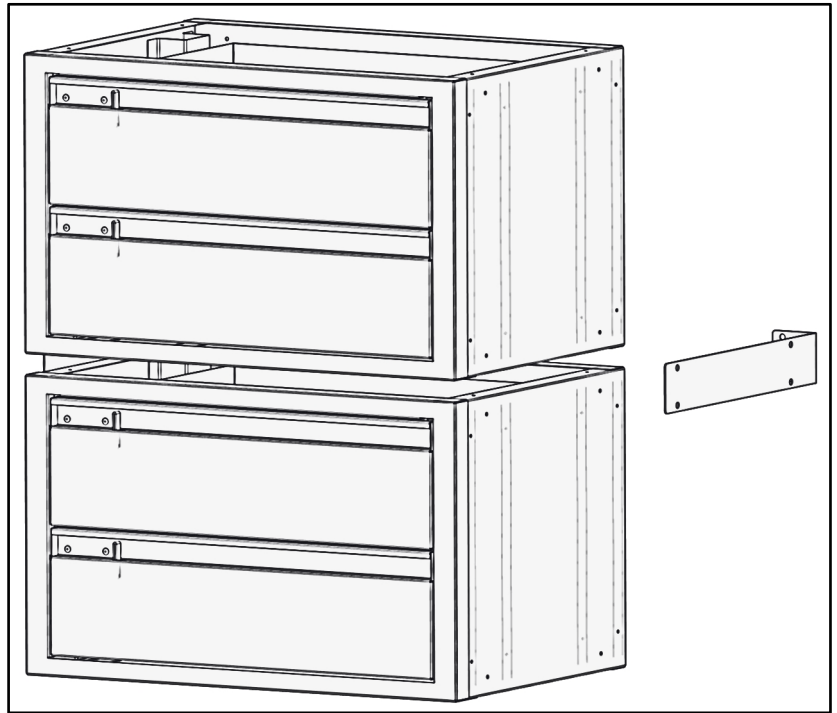

Step 2 – Assemble Top Tray

- On the top-drawer unit, place the tray so the holes from both units align. If the holes do not align, drill through the top tray and into the drawer unit using a 1/8" bit in the desired locations.
- Once the top tray is in the desired location, screw into place using four #14 screws.
- Tighten.

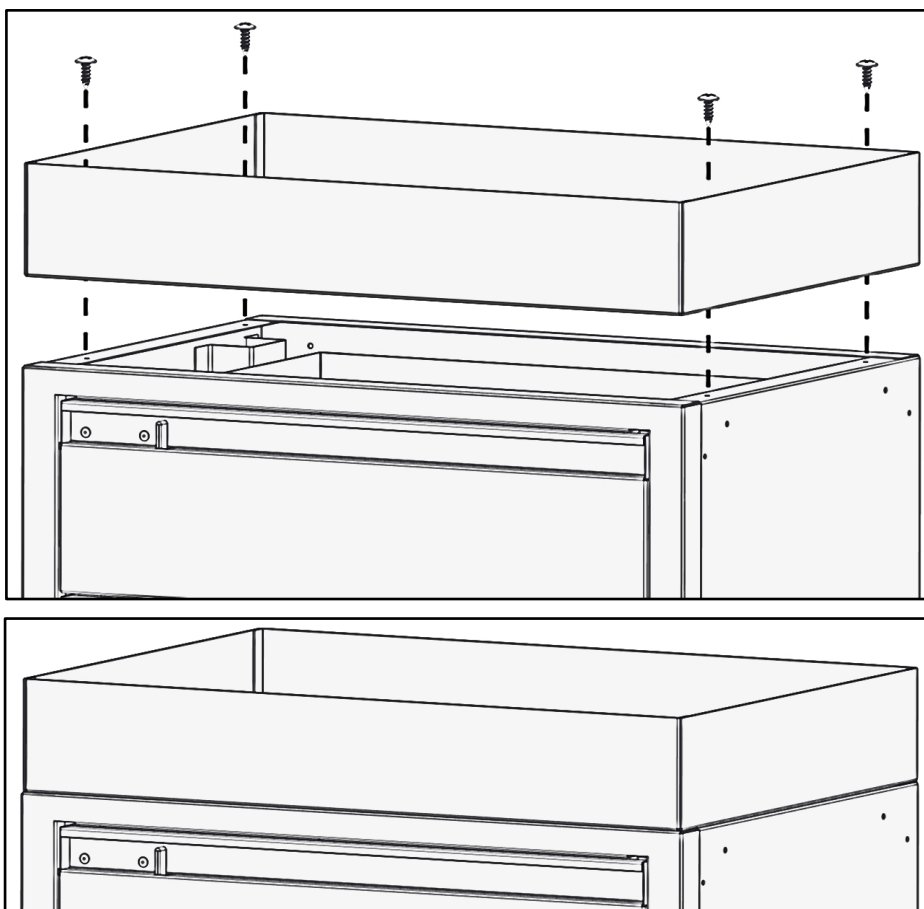

Step 3 – Assemble Floor Mounts

- Align and attach the floor mounts with the holes in the side of the bottom drawer unit using #14 screws as shown. Repeat on both sides.
- Tighten.

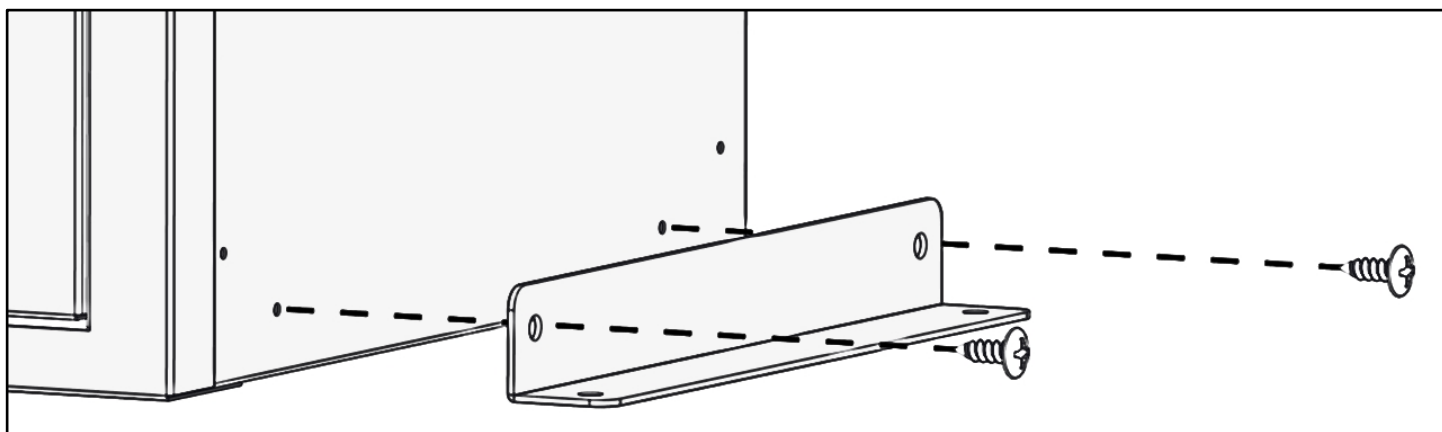

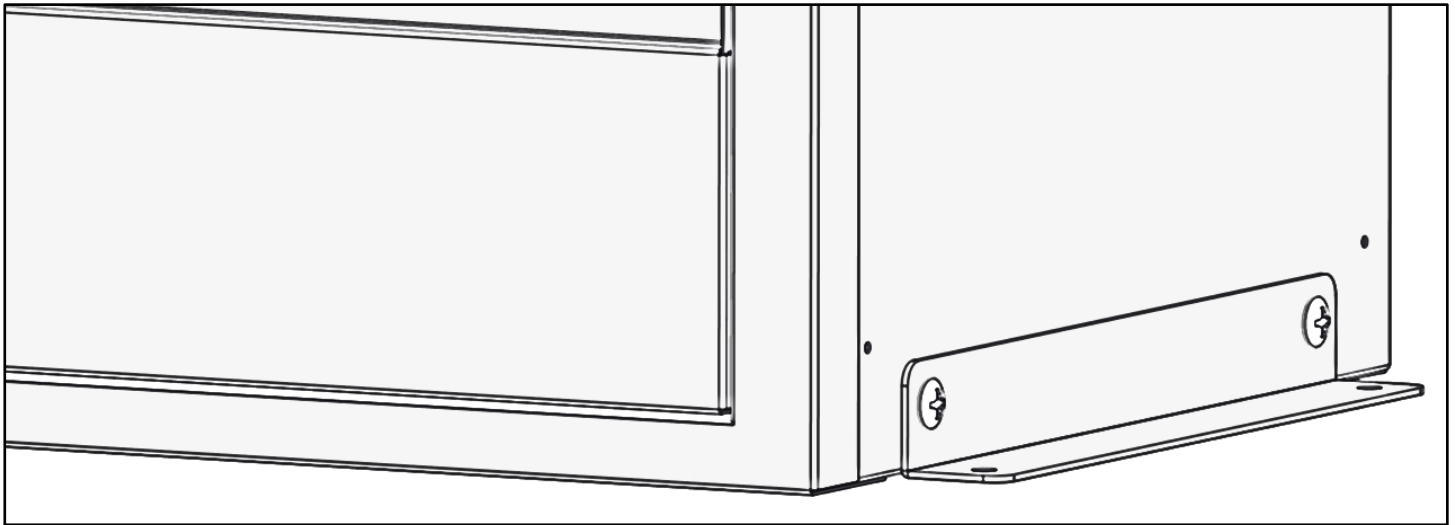

Step 4 – Installation into Vehicle

- Place the assembled drawer unit into the vehicle in the desired location. Align and square the unit as necessary.
- Mark through the four holes of the floor mounts onto the floor.
- Remove the assembled unit.
- **BE SURE THE LOCATION MARKED IS A SAFE PLACE TO DRILL INTO THE FLOOR.**

NOTE: If the vehicle has a floor mat, a 1” hole-saw is recommended to expose the metal floor.



DO NOT drill beyond depth of floor or upper installation surface. Always check for wires, fuel tanks and lines, brake lines and other important vehicle functionality items prior to drilling and installing all products.

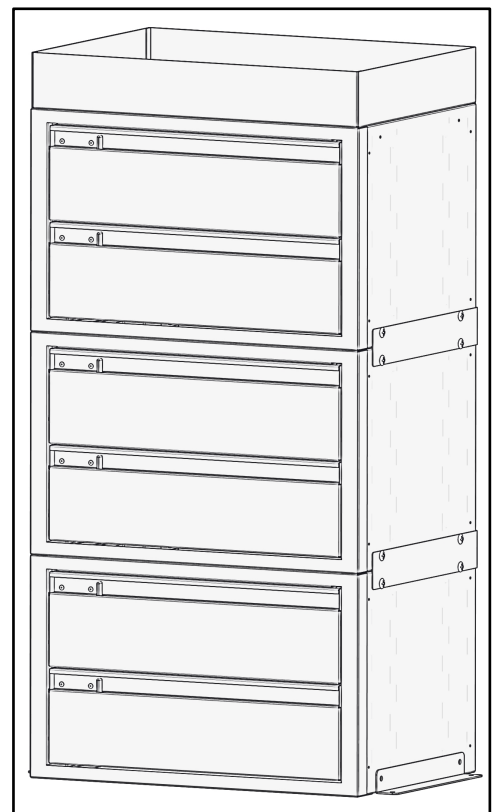

- At each marked location, drill hole using 25/64" drill bit and appropriate sized drill-bit stop collar. If 25/64" drill bit is not available, a 3/8" drill bit can be used, although it may be necessary to tap in the plus nuts.
- Insert 1/4" x 2-1/4" hex head bolt through 1/4" flat washer and plus nut installation tool, and then screw bolt into plus nut. Knurled end of plus nut tool must be directed away from bolt head and contacting plus nut.
- Insert plus nut into hole with plus nut tool attached.

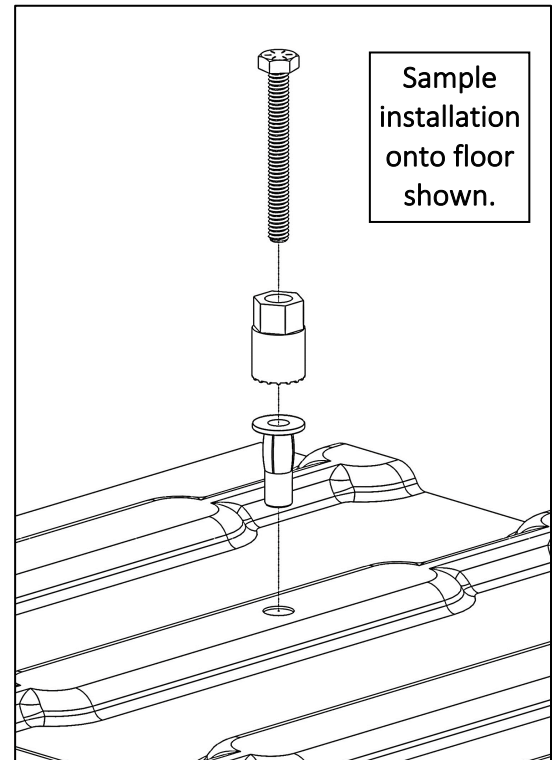

- Using the 9/16" box wrench, hold the plus nut tool stationary and then tighten hex head bolt until plus nut is tightly gripping and does not spin when hex bolt is loosened.
- DO NOT overtighten plus nut.

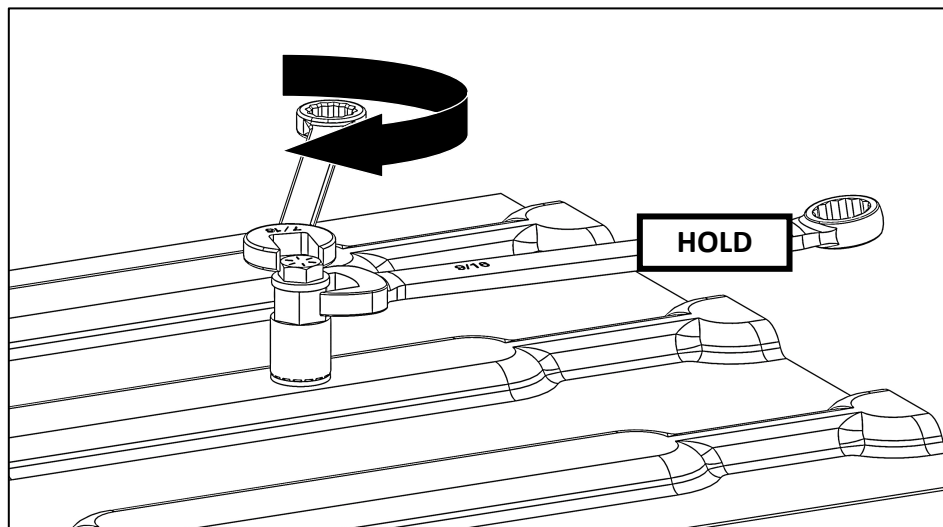

- Using the 9/16" box wrench, hold plus nut tool stationary to remove the 1/4" hex bolt.

- Place the assembled unit over the installed plus nuts.
- Bolt into place using 1/4" x 1" hex head bolt, 1/4" split lock washer and 1/4" flat washer.
- Repeat at all four locations.
- TIGHTEN.

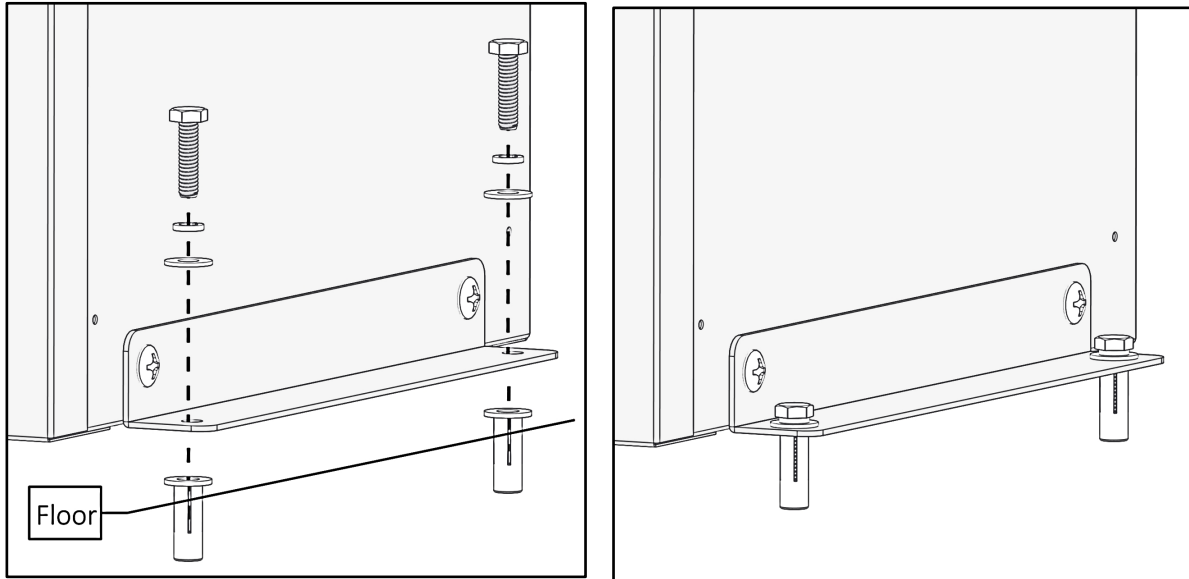

GO BACK AND ENSURE ALL HARDWARE IS TIGHT.

INSTALLATION IS NOW COMPLETE

