

Holman

Instruction Guide 40476GL

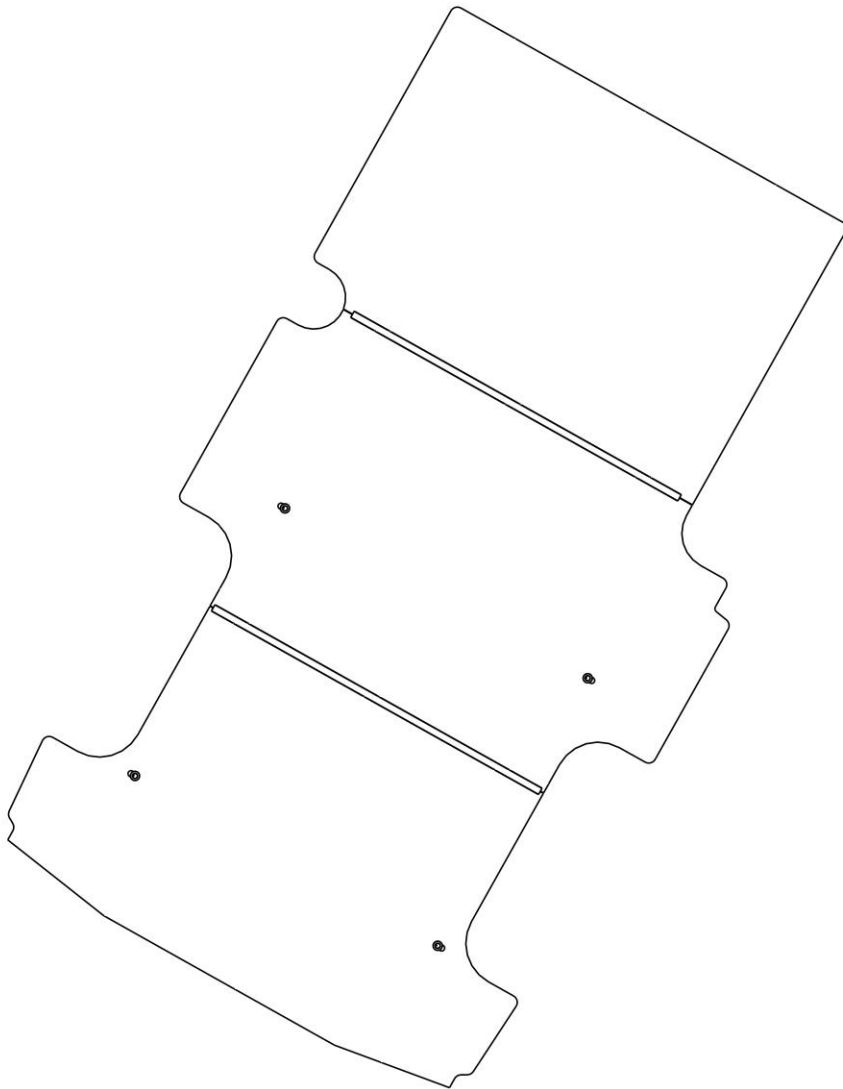

Holman
Rancho Cordova, CA 95742
800-343-7486
InstallationSupport@holman.com

PLEASE READ ALL INSTRUCTIONS AND WARNINGS PRIOR TO ASSEMBLING, INSTALLING, AND USING THIS PRODUCT.

Warning



Always check for wires, fuel tanks and lines, brake lines and other important vehicle functionality items prior to drilling and installing all products.



DO NOT USE IMPACT DRIVER TO INSTALL HARDWARE INTO FLOORING MATERIAL. SET DRILL DRIVER TO LOWEST SETTING AND INCREASE TORQUE ONLY AS NEEDED.

Tools Needed

17mm Socket and Socket Wrench	T45 Torque Bit
-------------------------------	----------------

Table of Contents

Before You Begin	1
40476GL Parts List.....	2
18-40476GL Floor Hardware	2
Step 1 – Remove Factory D-Rings	3
Step 2 – Position Floor	3
Step 3 – Install D-ring Bolts	3

Before You Begin

- Read all instructions prior to assembling or installing product.
- **Always locate your installation locations prior to performing any work.**
- **ENSURE SAFETY WHILE INSTALLING OR DRILLING INTO VEHICLE.**
- Any previously installed flooring must be removed prior to installing Holman flooring.
- Floor must be assembled in vehicle.
- 40477G threshold kit must be installed when installing Holman flooring. (40477G sold separately)

Parts List

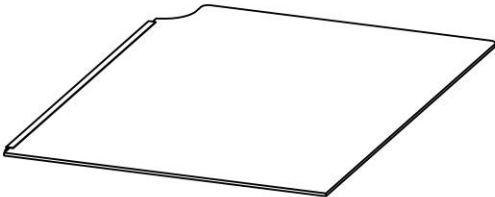
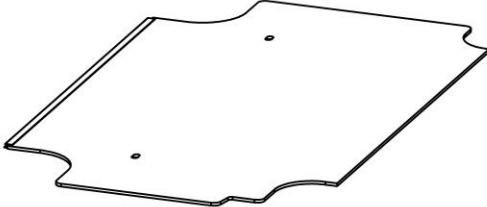
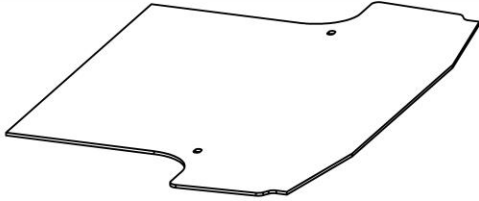
NO.	ITEM	PART NUMBER	DESCRIPTION	QTY.
1		101845	GM 155" FRONT FLOOR PAN	1
2		101846	GM 155" CENTER FLOOR PAN	1
3		101617	GM 155" WB REAR FLOOR PAN	1
4		18-40476GR	HARDWARE KIT	1

Floor Hardware

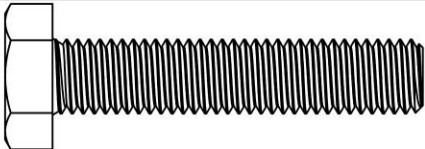
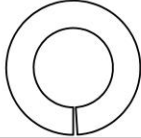
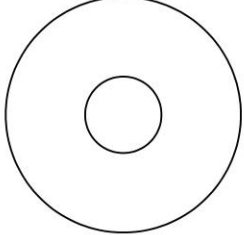
ITEM	HARDWARE TO SCALE	PART NUMBER	DESCRIPTION	QTY.
1		91280A642	M10-1.5 x 50MM HEX HEAD BOLT	4
2		ML6400000ZY0000	M10 Split Lock Washer	4
3		33220	3/8" FENDER WASHER	4

Step 1 – Remove Factory D-Rings

- Using T45 Torque bit remove four OEM D-Rings. **Be sure to save D-Rings if re-install is desired.**

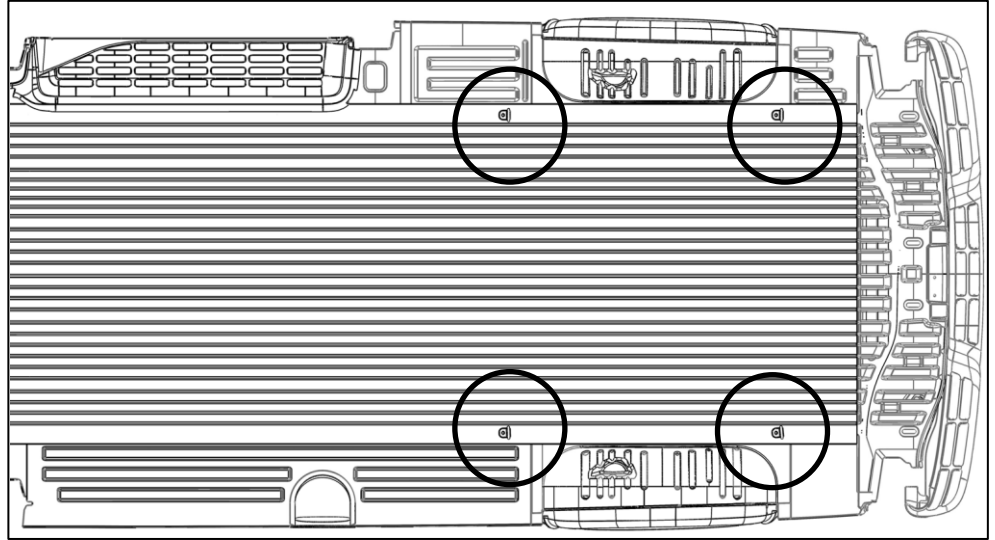

Step 2 – Position Floor

Floor must be assembled in vehicle.

- Set front panel in position.
- Press middle panel into aluminum extrusion of front panel.
- Press rear panel into aluminum extrusion of middle panel.

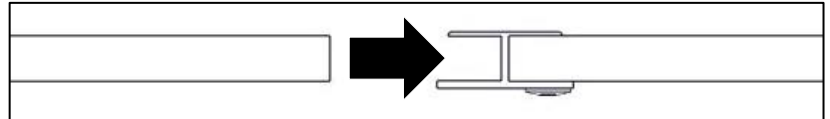

Step 3 – Install D-ring Bolts

Note: Floor must be secured using supplied hardware at OEM D-ring locations circled below even if it is not desired to re-install OEM D-Rings.

- If re-installing OEM D-Rings, remove OEM bolt from D-Ring.
- Using M10 x 50mm hex head bolt, M10 lock washer, OEM D-Ring and 3/8" fender washer, bolt through Holman floor at OEM D-Ring locations.

Note: If not re-installing OEM D-Ring use M10 x 50mm hex head bolt, M10 lock washer and 3/8" fender washer, bolt through floor at OEM D-Ring locations.

**GO BACK AND TIGHTEN ALL
HARDWARE.**

**INSTALLATION AND ASSEMBLY ARE
COMPLETE.**

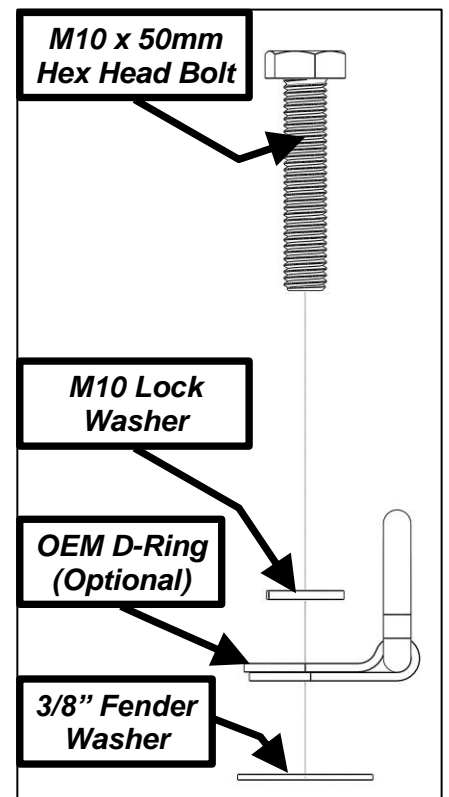

Attaching Accessories to Floor

Preferred Method

Note: Spacers are typically included with Holman accessories.

- Determine installation location.
- Drill a 1-1/8" hole through Holman floor in each mount location. **Be sure not to drill through metal van floor with 1-1/8" drill bit.**
- In the center of each hole, install a plus nut using the instructions below.
- Use 1" x 3/8" plastic spacer (Holman p/n 40501) in each hole as needed to attach accessories to steel van floor.

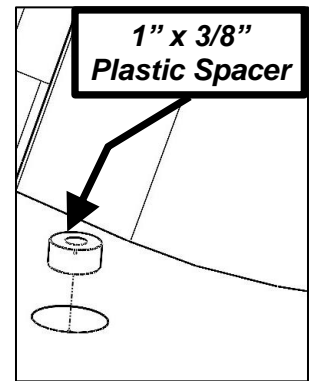

Alternate Method

⚠ This method should only be used when drilling into the van floor is not allowable. This method should not be used for top heavy accessories without additional support or excessively heavy items.

- Determine installation location.
- Drill a 5/16" hole through floor in each installation.
- Use 1/4" hardware and 1/4" t-nut threaded inserts* to install accessories to floor.

* T-nut threaded inserts sold separately in 40475HW hardware kit.

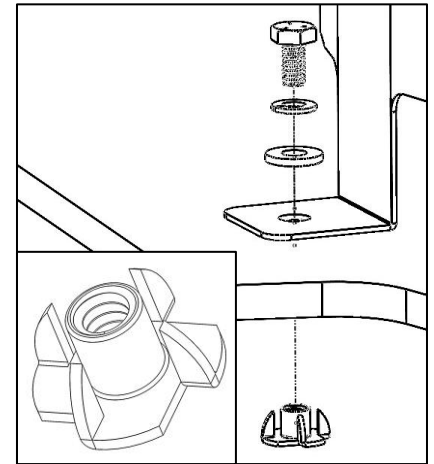

Install Plus Nuts

⚠ DO NOT drill beyond depth of floor or upper installation surface. Always check for wires, fuel tanks and lines, brake lines and other important vehicle functionality items prior to drilling and installing all products.

- At each marked location, drill hole using 25/64" drill bit and appropriate sized drill-bit stop collar. If 25/64" drill bit is not available, a 3/8" drill bit can be used, although it may be necessary to tap in the plus nuts.
- Insert 1/4" x 2-1/4" hex head bolt through 1/4" flat washer and plus nut installation tool, and then screw bolt into plus nut. **Knurled end of plus nut tool must be directed away from bolt head and contacting plus nut.**
- Insert plus nut into hole with plus nut tool attached.
- Using the 9/16" box wrench, hold the plus nut tool stationary and then tighten hex head bolt until plus nut is tightly gripping and does not spin when hex bolt is loosened.
- DO NOT overtighten plus nut.
- Using the 9/16" box wrench, hold the plus nut tool stationary to remove the 1/4" hex head bolt.

