

Holman

Instruction Guide 40477T

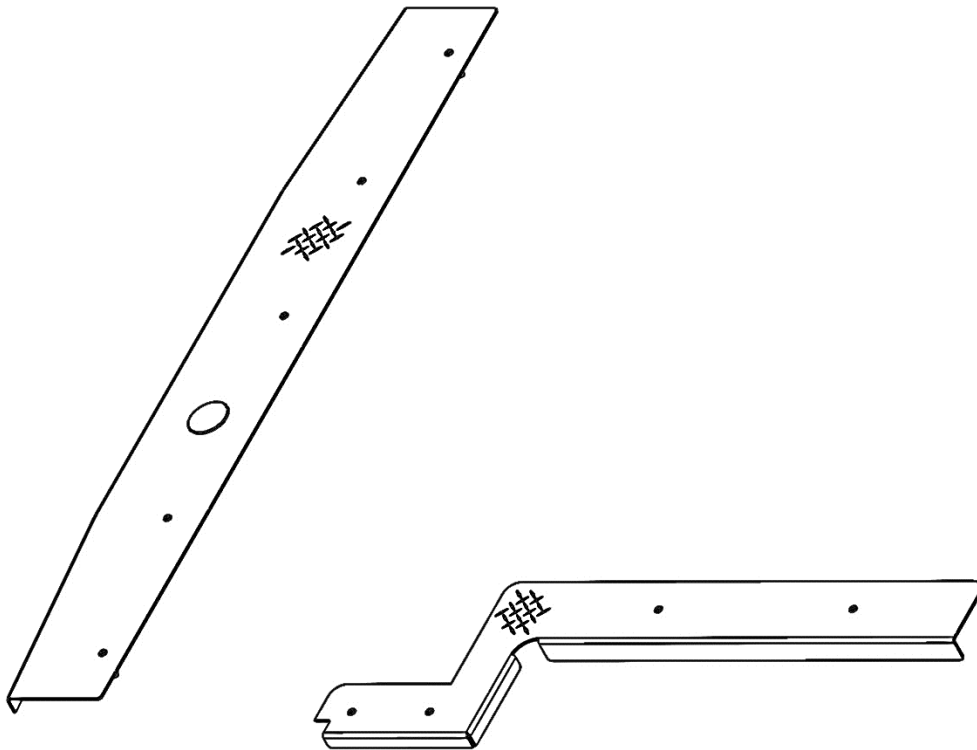

Holman
Rancho Cordova, CA 95742
800-343-7486
InstallationSupport@Holman.com

PLEASE READ ALL INSTRUCTIONS AND WARNINGS PRIOR TO ASSEMBLING, INSTALLING, AND USING THIS PRODUCT.

Warning



Always check for wires, fuel tanks and lines, brake lines and other important vehicle functionality items prior to drilling and installing all products.

Table of Contents

Tools Needed 1

Before You Begin 1

Parts List..... 2

Hardware 2

Step 1 – Trim Factory Threshold 2

Step 2 – Mark Holes For Door Threshold 3

Step 3 – Install Plus Nuts..... 3

Step 4 – Install Door Threshold 4

Step 5 – Mark Holes For Rear Threshold 4

Step 6 – Install Rear Threshold 5

Step 7 – Install Rubber Plug 5

Tools Needed

5/32" Allen Wrench	9/16" Box Wrench
25/64" Drill Bit	Plus Nut Installation Tool (P9902)*
Drill	7/32" Socket and Wrench
Trim Removal Tool	Oscillating Multi Tool

* Sold Separately.

Before You Begin

- Read all instructions prior to assembling or installing any Holman product.
- **Always locate your installation locations prior to performing any work.**
- **ENSURE SAFETY WHILE INSTALLING OR DRILLING INTO VEHICLE.**
- **Plus Nut Installation Tool Kit (P9902) is not included and must be purchased separately.**

Parts List

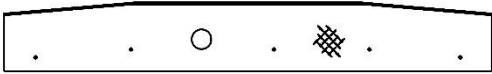
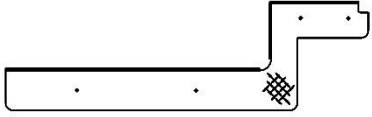
NO.	ITEM	PART NUMBER	DESCRIPTION	QTY.
1		101590	TRANSIT - REAR THRESHOLD	1
2		101591	TRANSIT - SLIDER THRESHOLD	1
3		18-40477T	HARDWARE KIT	1

Hardware

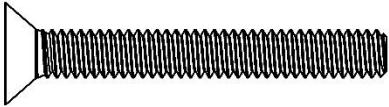
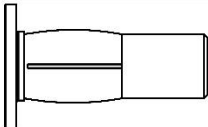
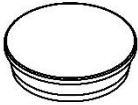
ITEM	HARDWARE TO SCALE	PART NUMBER	DESCRIPTION	QTY.
1		92210A550	1/4"-20 x 2" Flat Head Screw	9
2		93483A691	1/4"-20 Plus Nut	9
3		-	Rubber Plug 2.5" OD	1

Step 1 – Trim Factory Threshold

Some vehicles may be equipped with a plastic threshold by the sliding door, this needs to be either removed or trimmed before installing the Holman threshold.

- Remove plastic plugs from 4 locations circled.
- Using 7/32" socket remove the four screws circled. **Be sure not to lose screws. They will be needed for reinstallation.**
- Pry up using trim removal tool.
- Cut along the line shown below removing the entire top flange of the threshold.

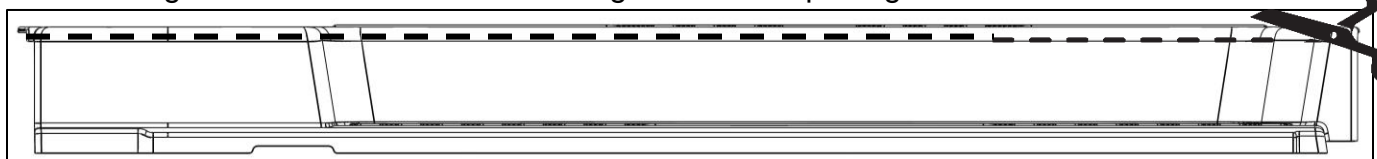
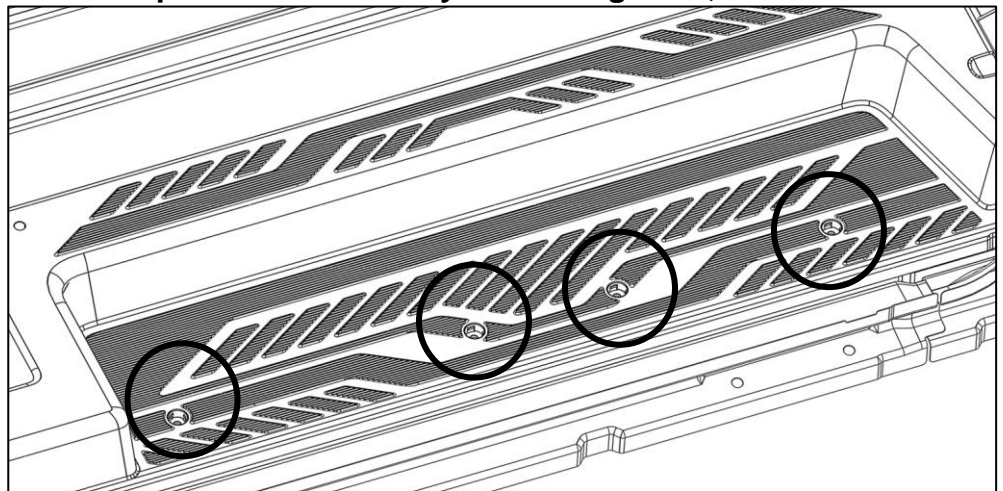

- Reinstall the threshold using previously removed screws.

Step 2 – Mark Holes For Door Threshold

- Place slider threshold into doorway of van. **Be sure to have the flanges in the down position.**

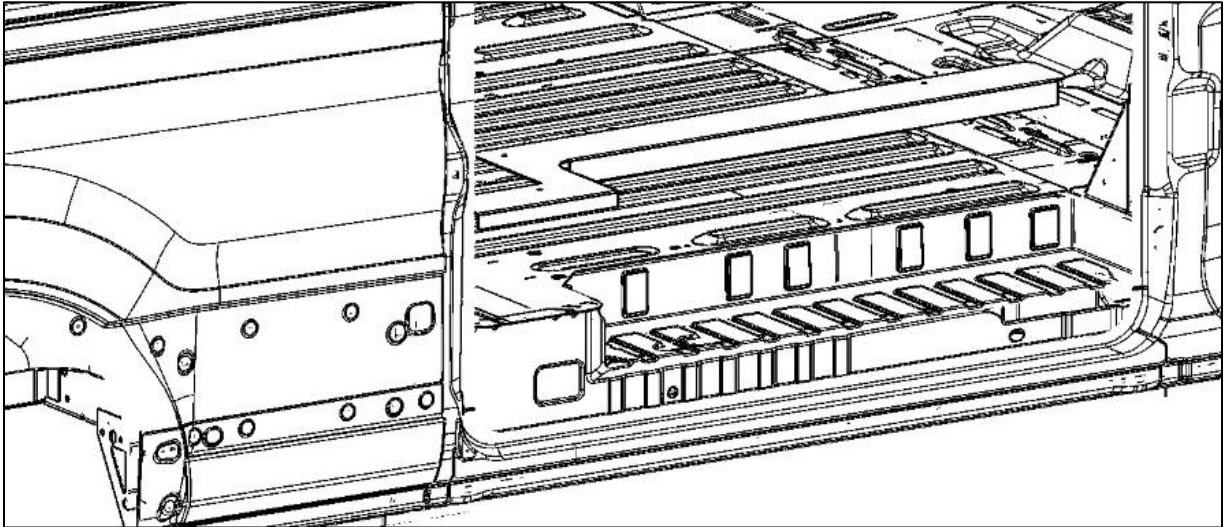

- While applying firm pressure against threshold, mark the four holes onto the floor or floor mat.

Step 3 – Install Plus Nuts



DO NOT drill beyond depth of floor or upper installation surface. Always check for wires, fuel tanks and lines, brake lines and other important vehicle functionality items prior to drilling and installing all products.

- At each marked location, drill hole using 25/64" drill bit and appropriate sized drill-bit stop collar. If 25/64" drill bit is not available, a 3/8" drill bit can be used, although it may be necessary to tap in the plus nuts.
- Insert 1/4" x 2-1/4" hex head bolt through 1/4" flat washer and plus nut installation tool, and then screw bolt into plus nut. Knurled end of plus nut tool must be directed away from bolt head and contacting plus nut.
- Insert plus nut into hole with plus nut tool attached.
- Using the 9/16" box wrench, hold the plus nut tool stationary and then tighten hex head bolt until plus nut is tightly gripping and does not spin when hex bolt is loosened.
- DO NOT overtighten plus nut.
- Using the 9/16" box wrench, hold the plus nut tool stationary to remove the 1/4" hex head bolt.

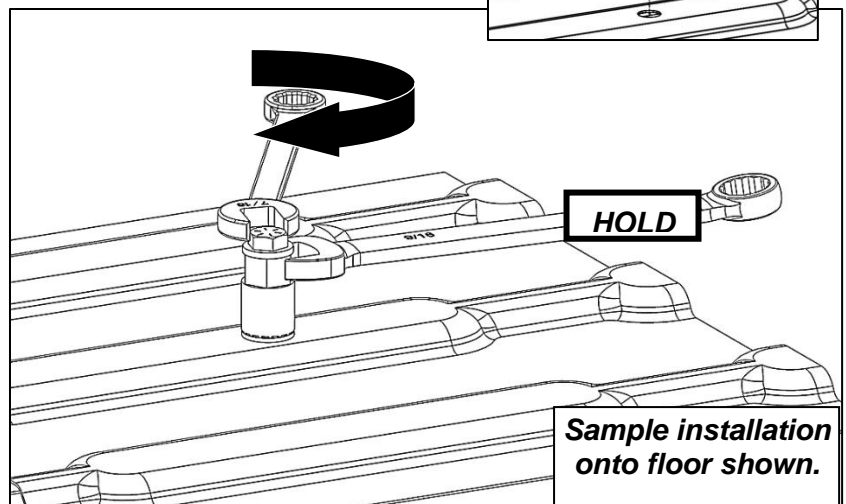
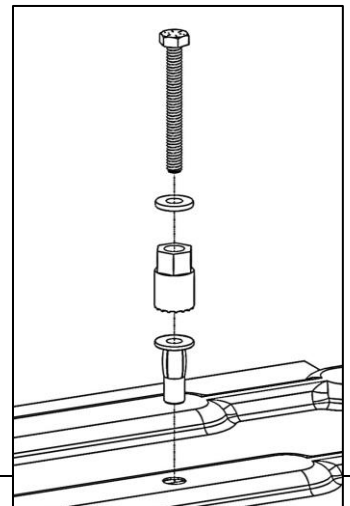

Step 4 – Install Door Threshold

- Place threshold back into van on top of previously installed plus nuts.
- Using four 1/4" x 2" flat head screws, bolt threshold to floor.

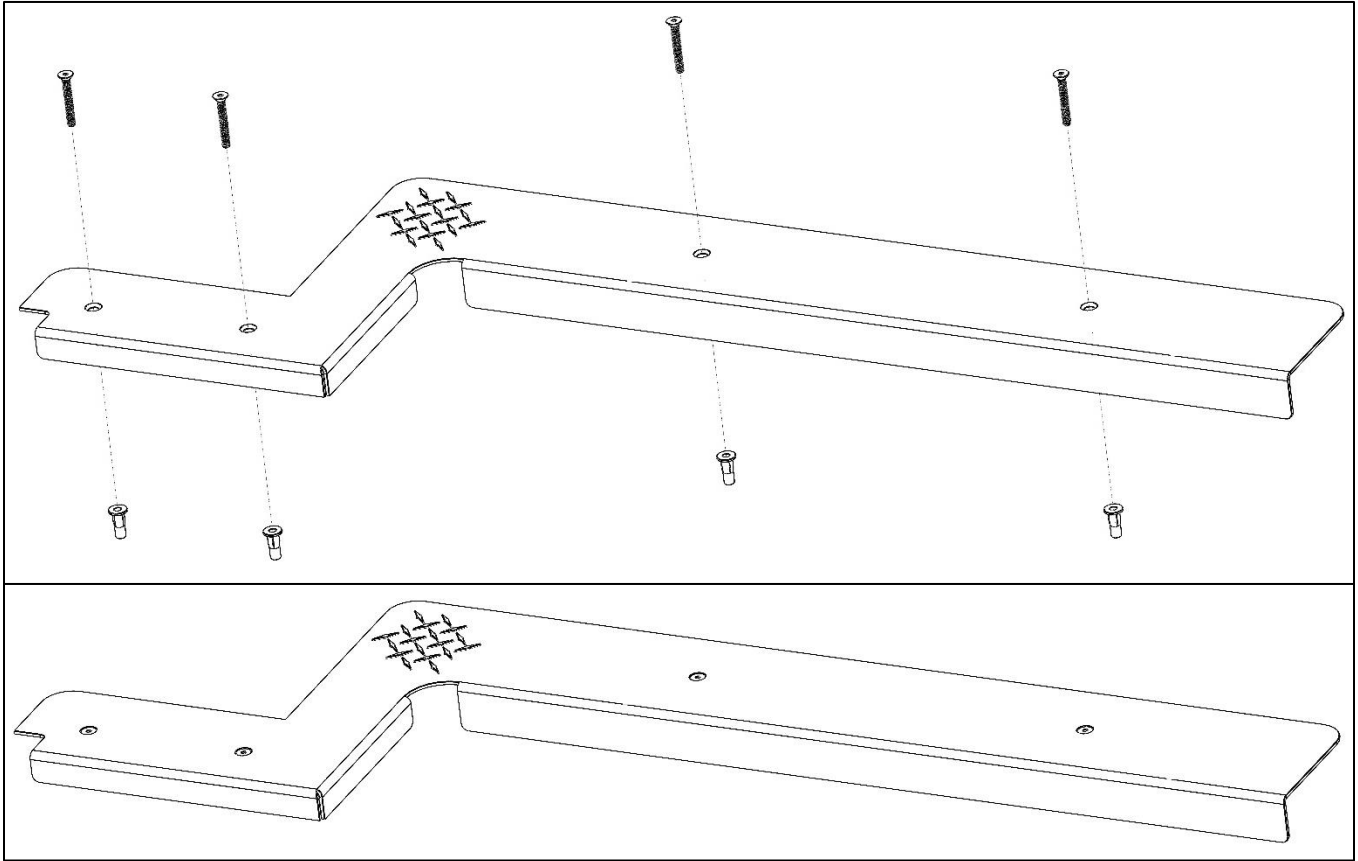

Step 5 – Mark Holes For Rear Threshold

- Place rear threshold into rear of van. **Be sure to have the flanges in the down position.**
- While applying firm pressure against threshold, mark the four holes onto the floor or floor mat.
- Remove threshold.



Make certain it is safe to drill.

- Drill and install plus nuts where previously marked, as instructed in Step 3.

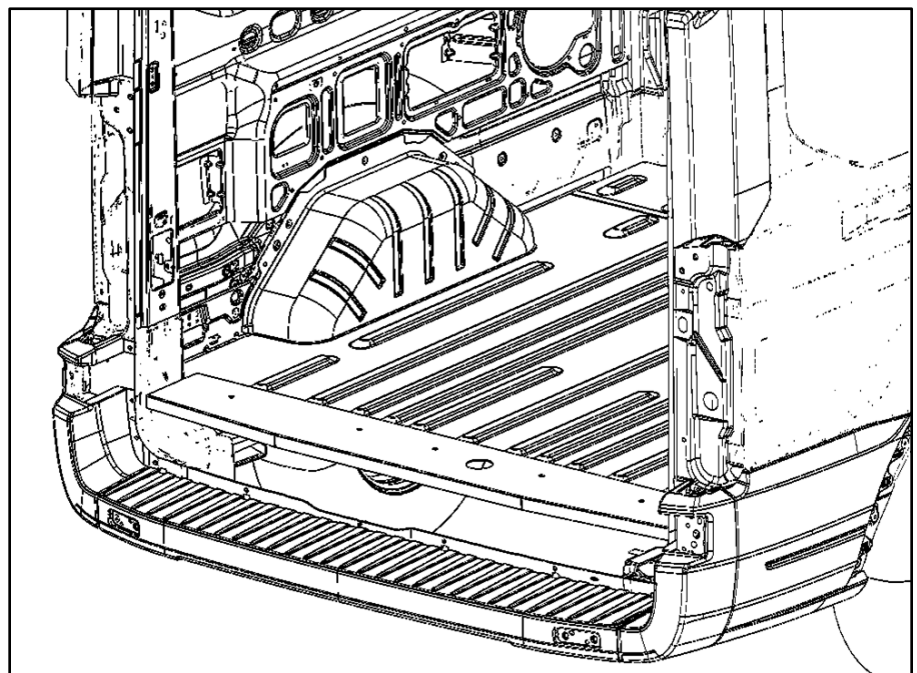

Step 6 – Install Rear Threshold

- Place threshold back into van, on top of previously installed plus nuts.
- Using five 1/4" x 2" flat head screws, bolt threshold to floor.

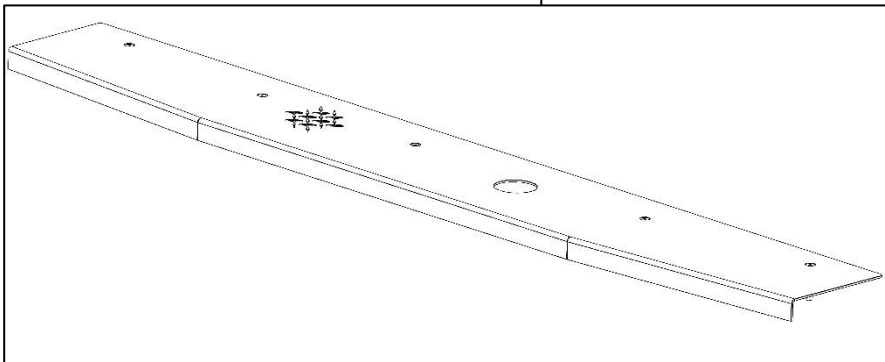
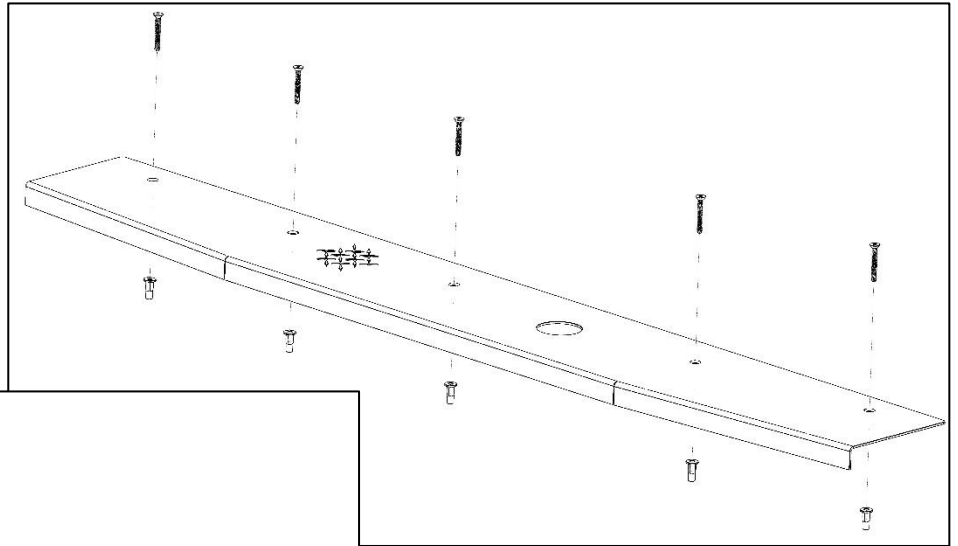

Step 7 – Install Rubber Plug

- Insert 2-1/2" rubber plug into spare tire access hole and press down firmly until fully seated.

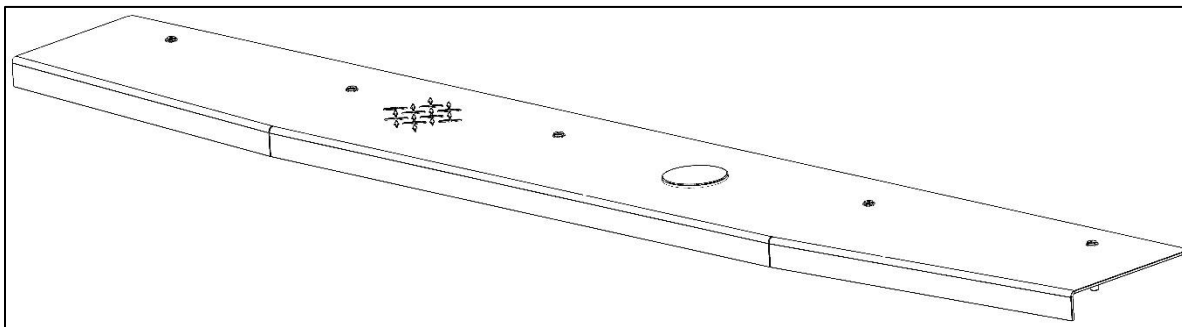
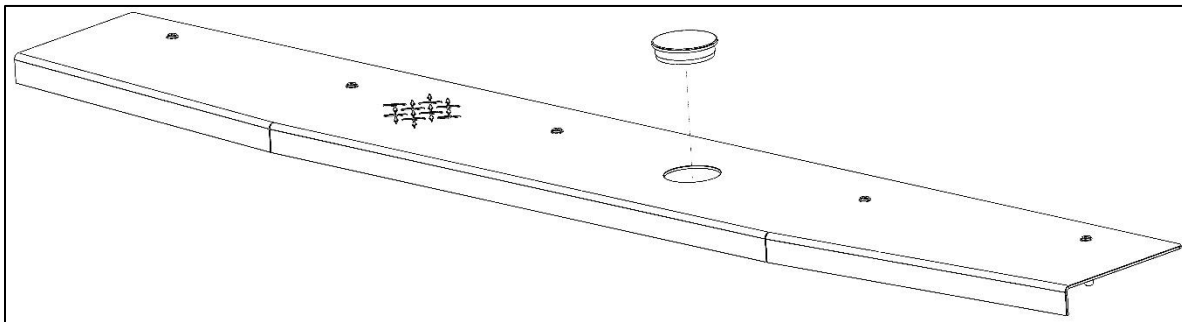

GO BACK AND TIGHTEN ALL HARDWARE.
INSTALLATION IS COMPLETE.