

# Holman

---

## Instruction Guide 40649TL

---

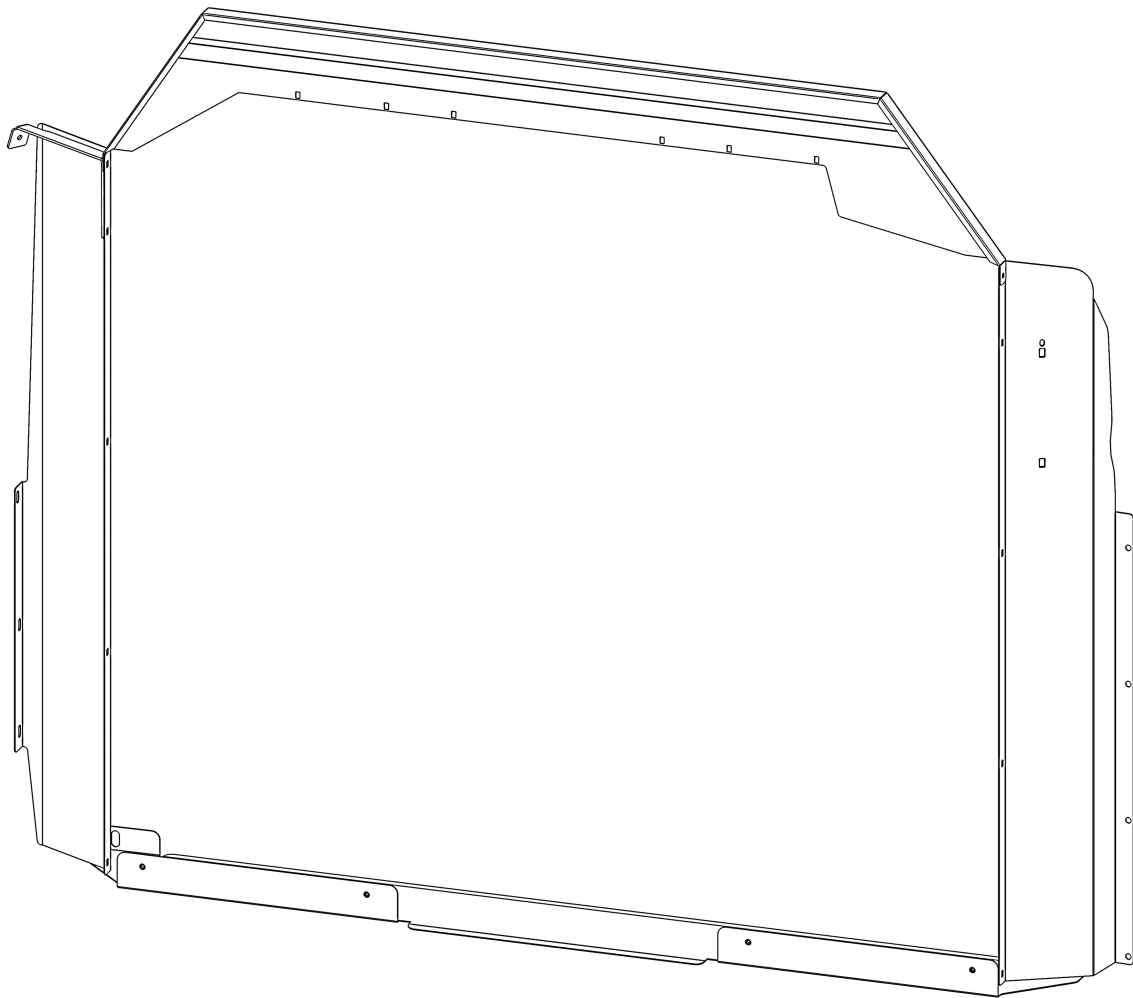

---

Holman  
Rancho Cordova, CA 95742  
800-343-7486  
InstallationSupport@Holman.com

---

**\*PLEASE READ ALL INSTRUCTIONS AND WARNINGS PRIOR TO ASSEMBLING, INSTALLING, AND USING THIS PRODUCT.\***

## Warning



**Always check for wires, fuel tanks and lines, brake lines and other important vehicle functionality items prior to drilling and installing all products.**

## Tools Needed

7/16", 1/2", 5/8" Sockets and Wrench	7/16", 9/16" Box Wrench
Drill	25/64" Drill Bit
Phillips Driver	10mm Socket and Wrench
Drill Bit Stop Collar	Plus Nut Installation Tool (P9902)*

**\* Sold Separately.**





## Table of Contents

Parts List .....	2
Hardware.....	2
Step 1 – Attaching Side Wings.....	4
Step 2 – Attaching Top Panel .....	5
Step 3 – Attaching Bottom Plate .....	5
Step 4 – Attaching Roof Support .....	6
Step 5 – Installing Handle Mount .....	6
Step 6 – Installation Preparation.....	7
Step 7 – Installing Plus Nuts into Floor.....	8
Step 8 – Installing Partition to Plus Nuts .....	9
Step 9 – Installing Driver Side Wing to Van Siding.....	10
Step 10 – Installing Roof Support to Van Siding.....	11
Step 11 – Installing Handle to Handle Bracket .....	11
Step 12 – Installing Wing to “B” Pillar .....	12

## Before You Begin

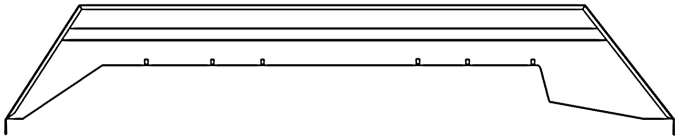
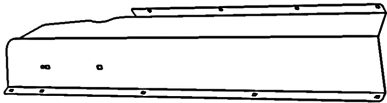
- **Read all instructions prior to installing any Holman product.**
- **Be sure to have 40640 partition assembled and ready to be installed before continuing.**
- **Plus Nut Installation Tool Kit (P9902) is not included and must be purchased separately.**

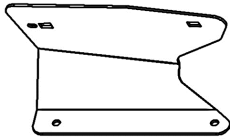

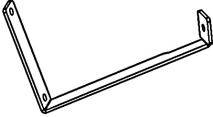

## Parts List

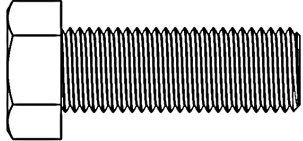
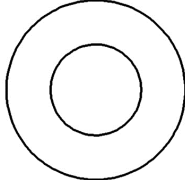
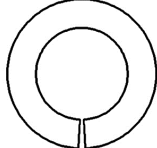
ITEM NO.	ITEM	PART NUMBER	DESCRIPTION	QTY
1		406TL-20	Top Panel ASM	1
2		406TL-10-002-R2	Transit Low Roof-PS Wing	1
3		406TL-10-003-R2	Transit Low Roof-DS Wing	1
4		406TL-10-004	Transit Low Roof-Handle Mount	1
5		406TL-30	Bottom Panel ASM	1
6		406TL-10-005	Transit Low Roof DS Support	1
8		18-40649TL	Hardware	1

## Hardware

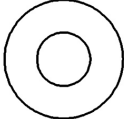
ITEM	HARDWARE TO SCALE	PART NUMBER	DESCRIPTION	QTY.
1		17157	7/16-20 X 1-1/4" Hex Head Bolt	2
2		1133084	7/16" Washer	2
3		33624	7/16" LOCKING WASHER	2

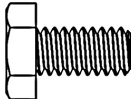
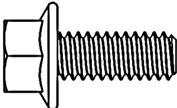
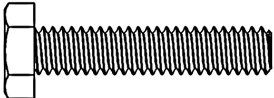
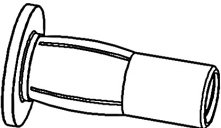
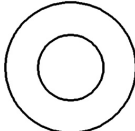
**Hardware (Continued)**

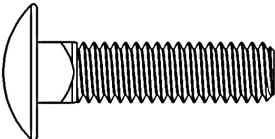
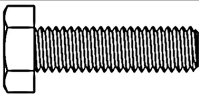
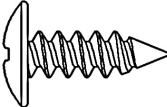
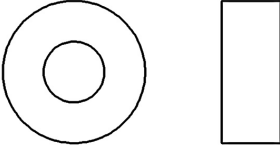
ITEM	HARDWARE TO SCALE	PART NUMBER	DESCRIPTION	QTY.
4		33618	1/4" LOCK WASHER	14
5		33078	1/4" FLAT WASHER	14
6		0167030	1/4"-20 FLANGED LOCK NUT	20
7		11241162	1/4"-20 X 1/2" HEX HEAD BOLT	4
8		11126953	1/4"-20 X 5/8" FLANGED HEX HEAD	16
9		13800	1/4"-20 X 1-1/4" HEX HEAD BOLT	8
10		920313726	1/4"-20 PLUS NUT	8
11		33080	5/16" WASHER	2
12		0169777	5/16"-18 LOCK NUT	2
13		11137256	5/16-18 X 1-1/4" CARRIAGE BOLT	2
14		38566	M6-1 X 25MM HEX HEAD BOLT	2
15		0142198	#14-10X3/4 SHEET METAL SCREW	4
16		11517442	3/8" ID 1" OD NYLON SPACER	4



## Step 1 – Attaching Side Wings

- Using four 1/4" x 5/8" flanged bolts and four 1/4" flanged lock nuts, bolt passenger side (PS) side wing to partition.
- Snug tighten but allow for movement.
- Using four 1/4" x 5/8" flanged bolts and four 1/4" flanged lock nuts, bolt driver's side (DS) wing to partition.
- Snug tighten but allow for movement.

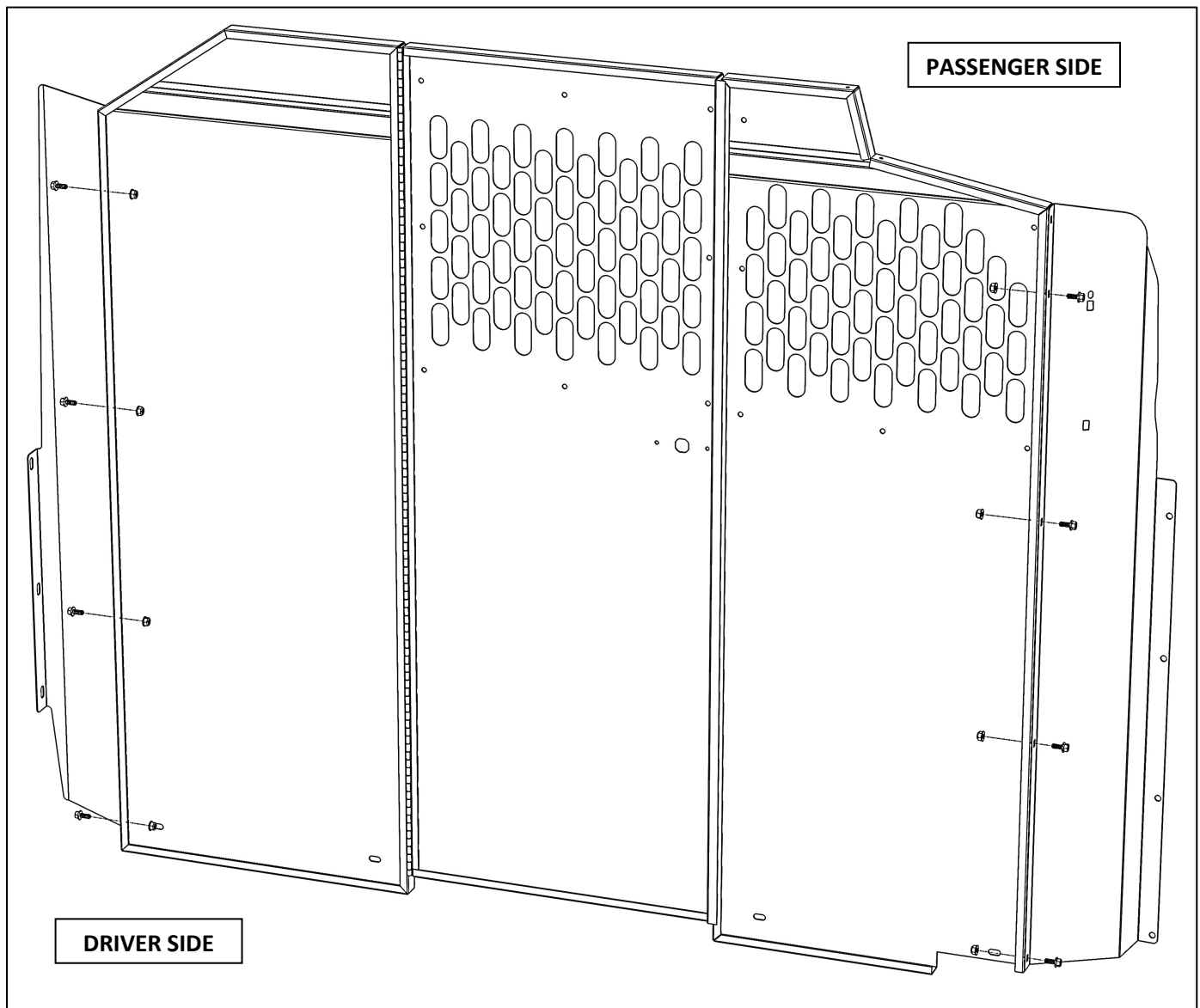
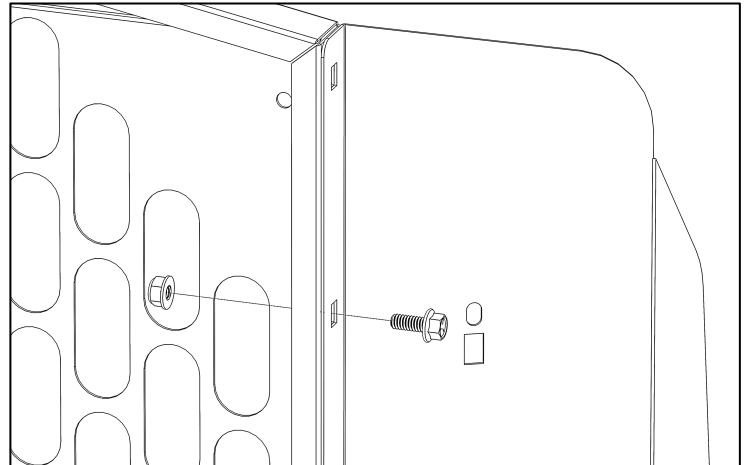

## **Step 2 – Attaching Top Panel**

- Using six 1/4" x 5/8" flanged bolts and a 1/4" flanged lock nuts, bolt top wing to partition.
- Snug tighten but allow for movement.

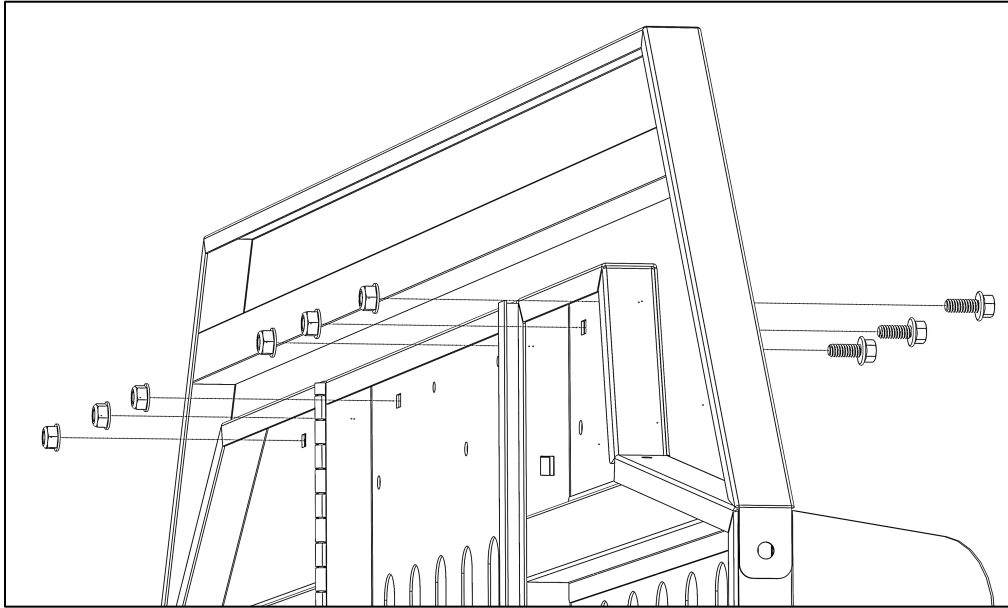

## **Step 3 – Attaching Bottom Plate**

- Using four 1/4" x 1/2" hex head bolts, four 1/4" lock washer, and four 1/4" washers, bolt through the partition panels into the bottom panel.
- Snug tighten but allow for movement.

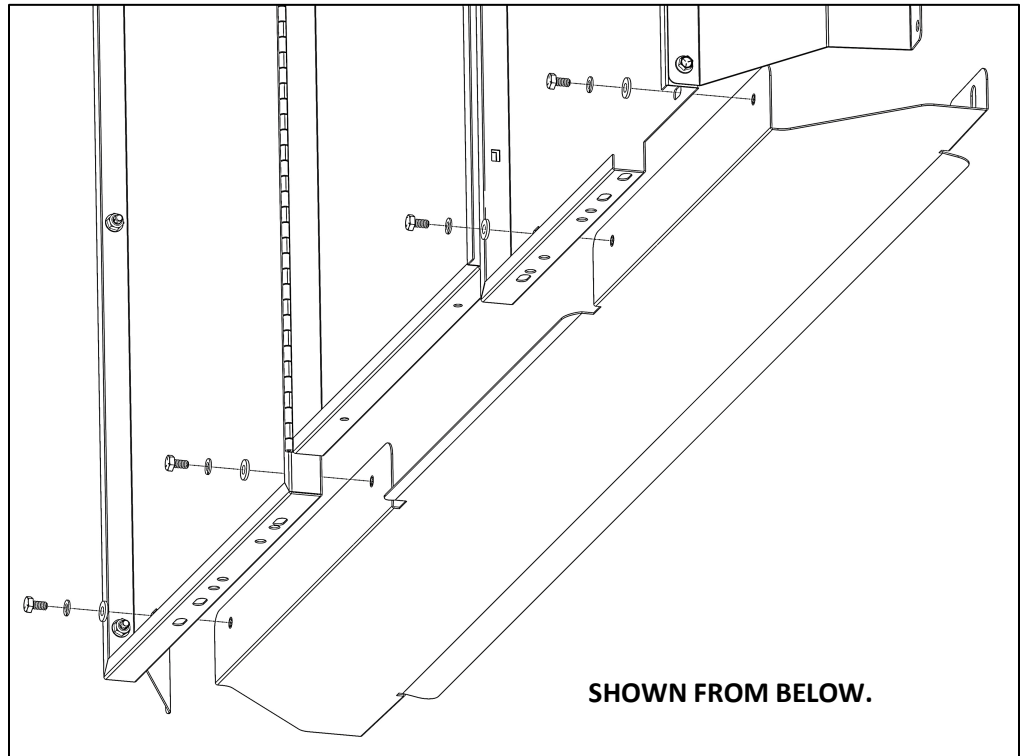

## **Step 4 – Attaching Roof Support**

- Using a 1/4" x 5/8" flanged bolt and a 1/4" flanged lock nut and the previously installed 1/4" x 5/8" flanged bolt and 1/4" flanged lock nut, LOOSELY bolt the roof support to DRIVER SIDE of partition.

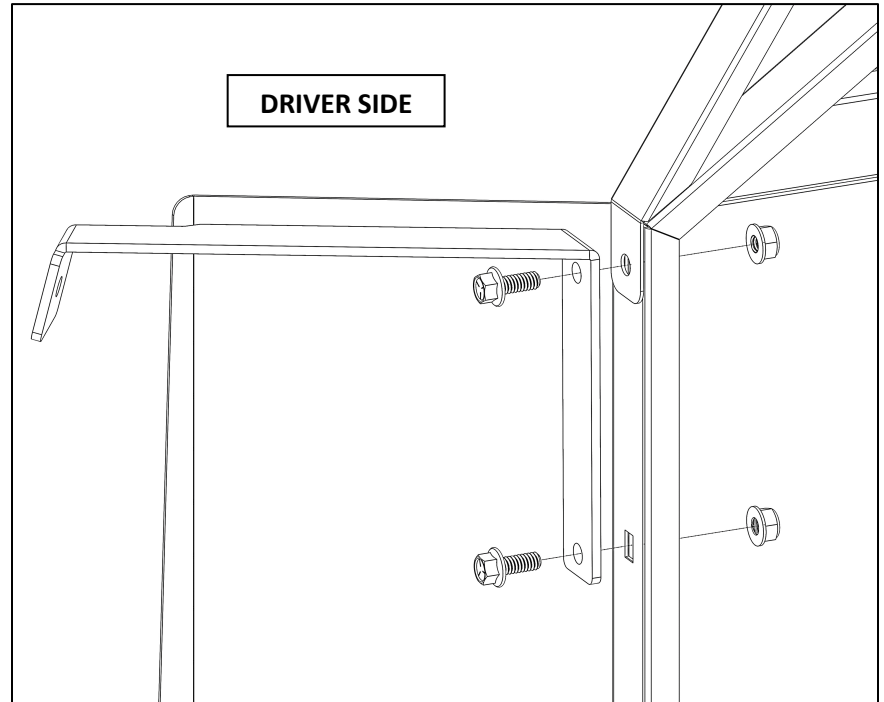

## **Step 5 – Installing Handle Mount**

- Remove handle from slider doorway as shown below.

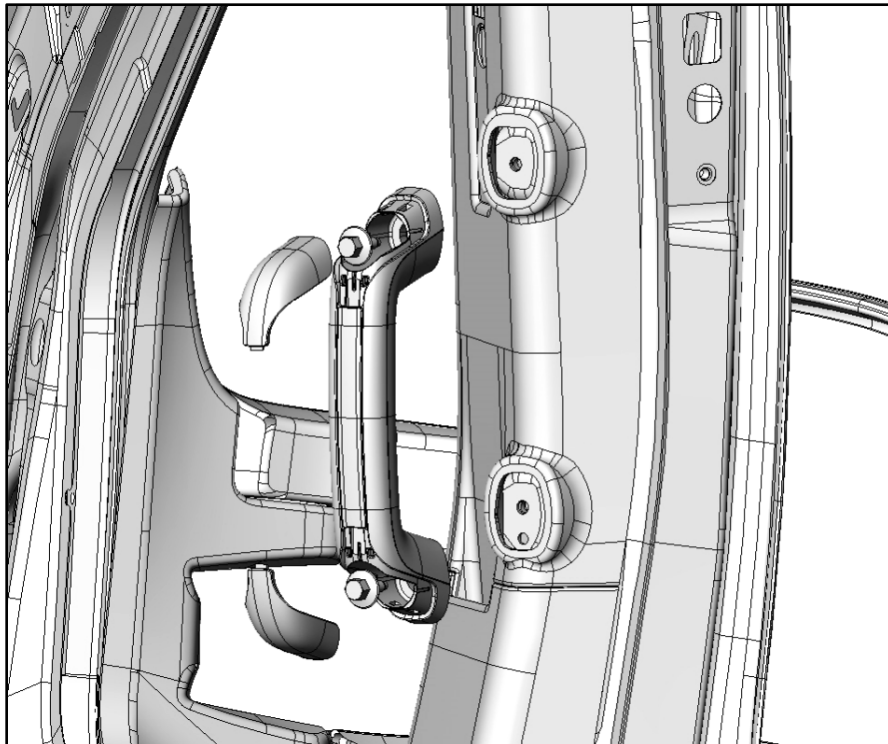

- Using M6 x 25mm hex head bolts, 1/4" lock washers and 1/4" washers, install handle mount where handle was previously removed.
- Snug tighten but allow for movement.

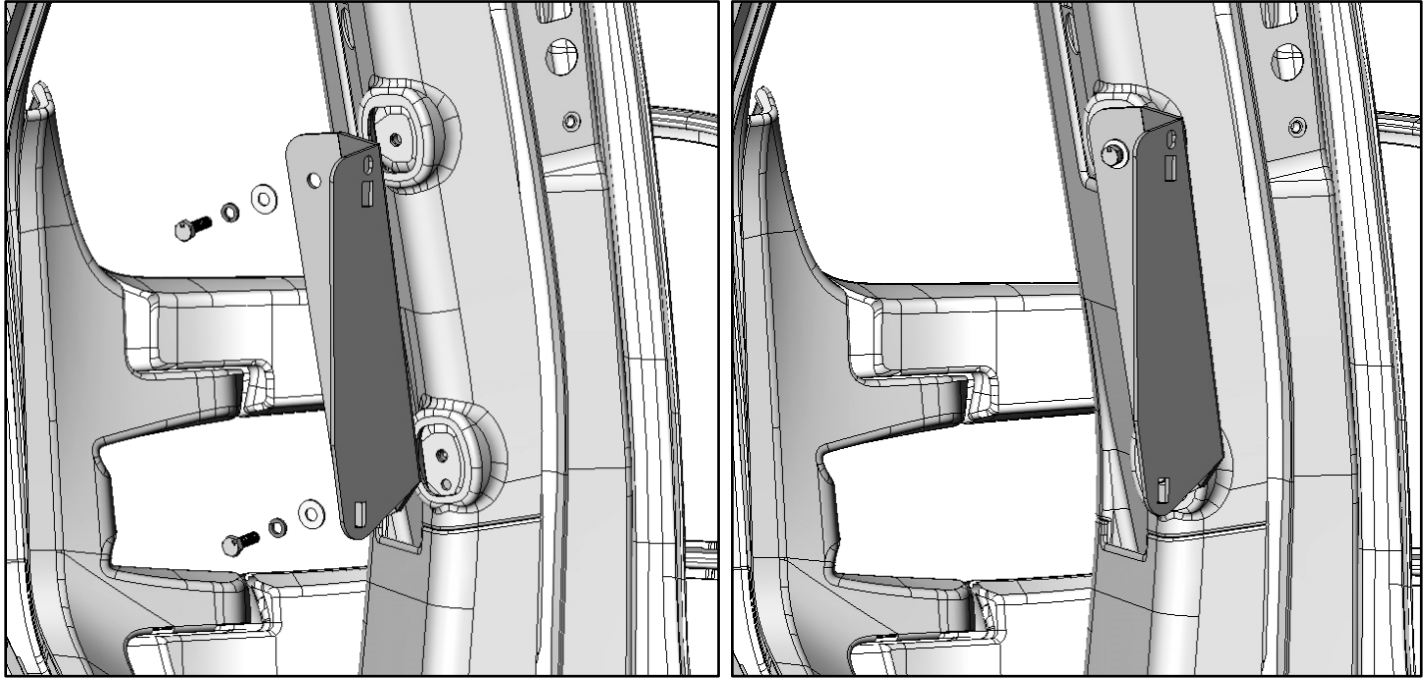

### **Step 6 – Installation Preparation**

**NOTE: Newer vehicle models do not come with factory-installed D-rings.**

- If your vehicle has factory-installed D-rings, remove the D-rings from both the driver's side and passenger side "B" pillars.
- If wall liner is installed on driver-side sidewall behind the driver's seat, remove wall liner and wall liner holding clips nearest the driver's seat. Wall liner can be reinstalled later on during installation.

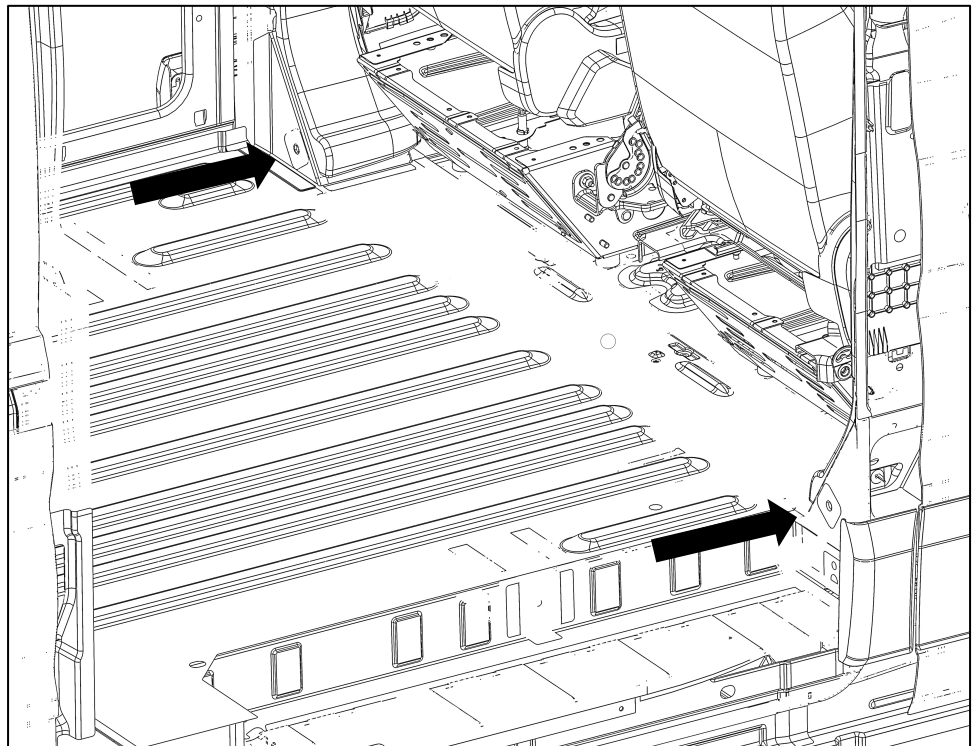

## Step 7 – Installing Plus Nuts into Floor

- Place assembled partition with wings into van with the flanged side of partition facing to the rear and wings bent towards the front.
- Push the partition firm against the passenger side “B” pillar.
- Align holes in passenger side wing with previously installed handle mount.
- On the driver’s side, the holes in the outside edge of the wing should line up with three existing holes on the side of the van.
- Holding the partition in place, use a straight edge to ensure the bottom of the partition is straight and square with van.
- Be sure this is the desired location to install the partition.
- Mark all holes and slots along floor.
- Remove partition with wings.
- Based upon lack of obstructions and ease of installation, determine which four locations on each partition panel to drill into floor.

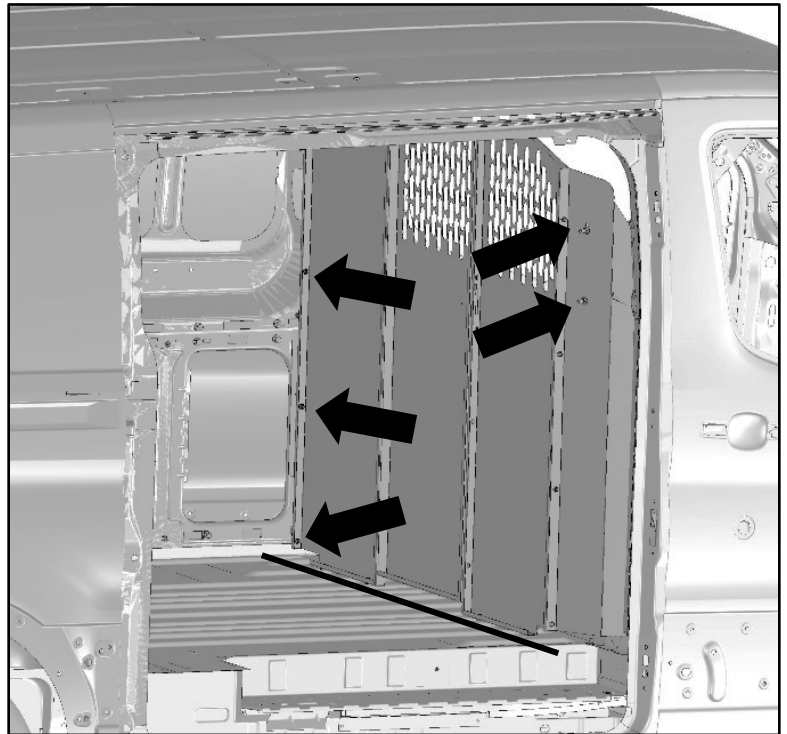

**DO NOT drill beyond depth of floor. Always check that each location is clear of wires, fuel tanks and lines, brake lines and other important vehicle functionality items prior to drilling and installing any product.**



**Use a drill stop to avoid unnecessary damage.**

- At each marked location, drill hole using 25/64” drill bit and appropriate sized drill-bit stop collar. If 25/64” drill bit is not available, a 3/8” drill bit can be used, although it may be necessary to tap in the plus nuts.
- Insert 1/4” x 2-1/4” hex head bolt through 1/4” flat washer and plus nut installation tool, and then screw bolt into plus nut. Knurled end of plus nut tool must be directed away from bolt head and contacting plus nut.

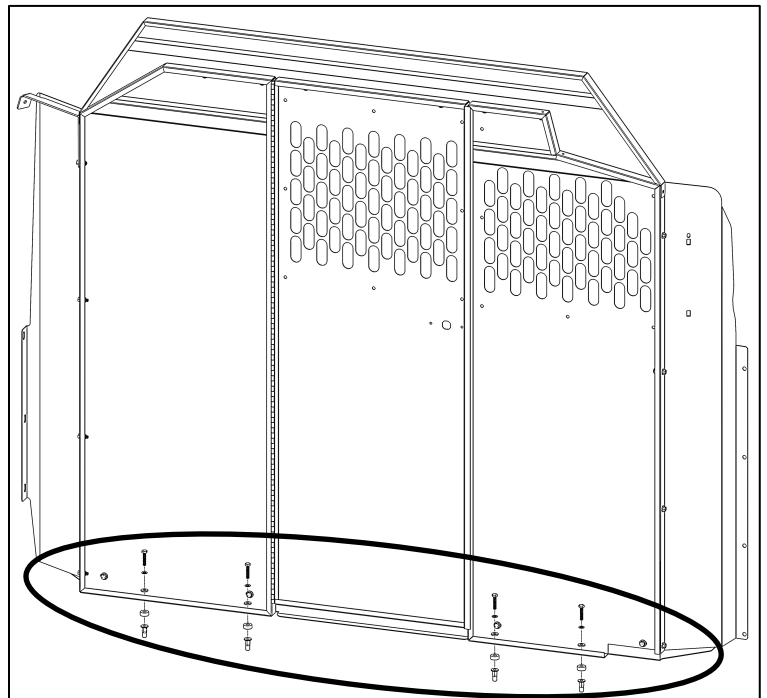



- Insert plus nut into hole with plus nut tool attached.
- Using the 9/16" box wrench, hold the plus nut tool stationary and then tighten hex head bolt until plus nut is tightly gripping and does not spin when hex bolt is loosened.
- **DO NOT overtighten plus nut.**
- Using the 9/16" box wrench, hold the plus nut tool stationary to remove the 1/4" hex head bolt.

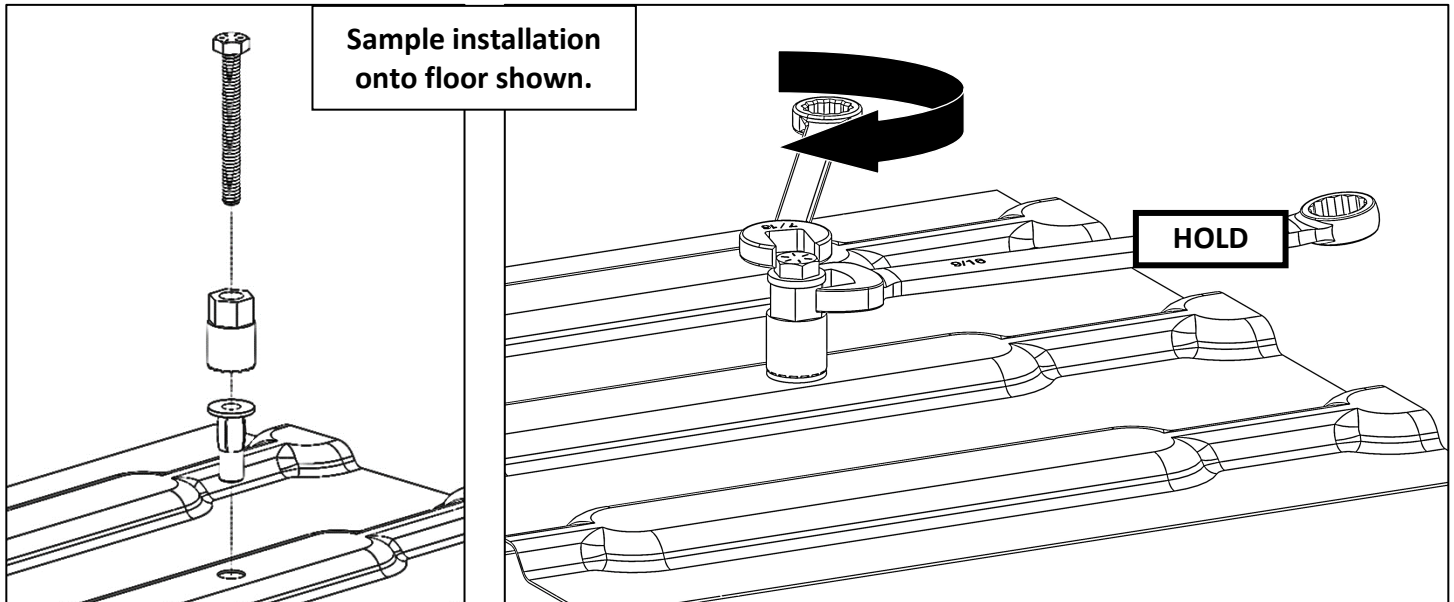

### **Step 8 – Installing Partition to Plus Nuts**

- Place assembled partition with wings back into van. Align with previously installed plus nuts.
- Along the floor, at each plus nut, bolt through partition panels using 1/4" x 1-1/4" hex head, 1/4" lock washer, and a 1/4" flat washer.
- Insert nylon spacer underneath partition if needed.
- Snug tighten but allow for movement.

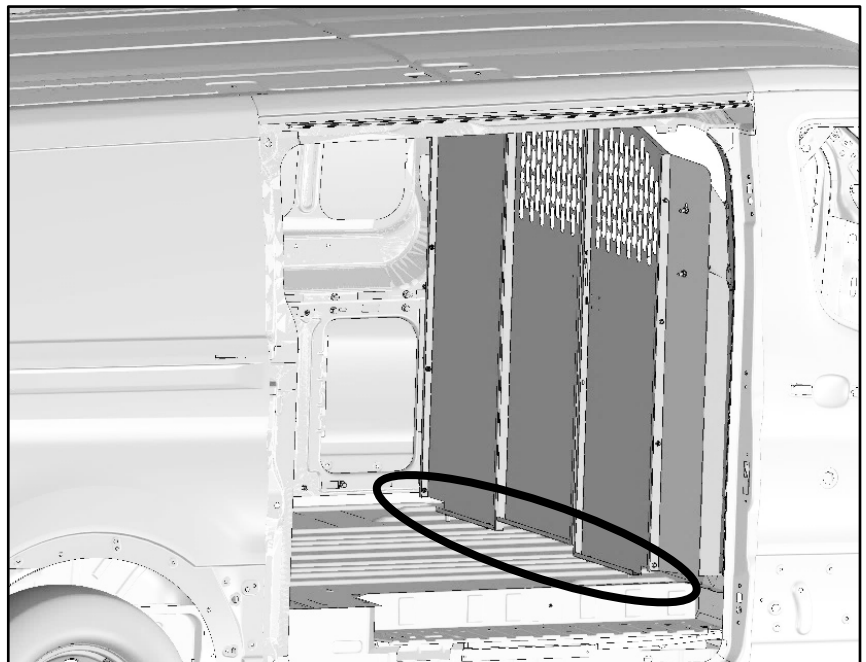

## Step 9 – Installing Driver Side Wing to Van Siding

- On the driver's side of van, the driver's wing should line up with three (3) factory holes in the van siding.
- There are two options for installing the wing to the driver's side van siding.
  - The first option is to bolt through the wing and the hole in the side of the van using a 1/4" x 1-1/4" hex bolt, a 1/4" lock washer, a 1/4" washer, and a 1/4" flanged lock nut.
  - The second option is to install a plus nut into the existing holes in the van siding, and then bolt through the wing into each plus nut using a 1/4" x 1-1/4" hex bolt, a 1/4" lock washer, and a 1/4" washer.
  - **NOTE: If wall liner was removed, it may be desirable to install the three plus nuts and then reinstall the wall liner by sandwiching it between the driver side wing and the van siding.**
- Snug tighten but allow for movement.

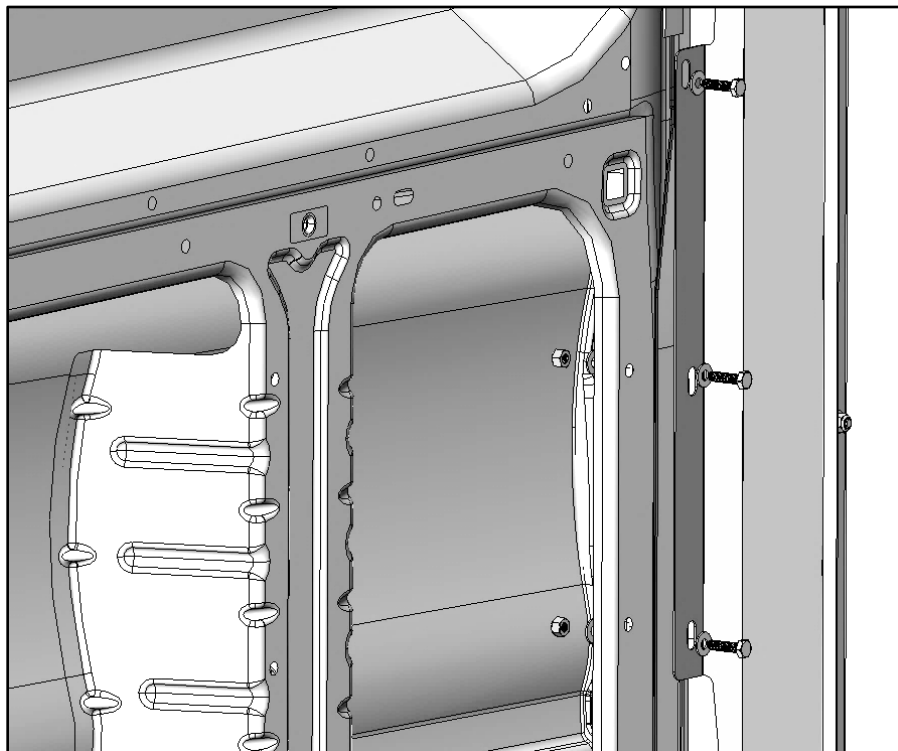
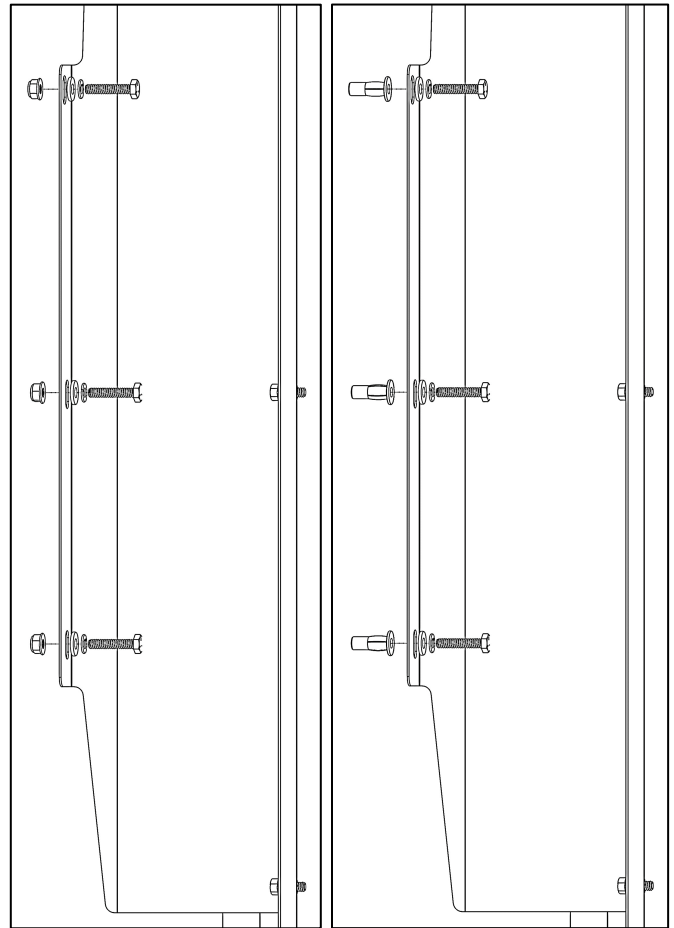

## **Step 10 – Installing Roof Support to Van Siding**

- On the driver's side of van, the roof support should line up with a factory hole high in van siding.
- Install a plus nut into the existing hole in the van siding.
- Bolt through the roof support into the plus nut using a 1/4" x 1-1/4" hex bolt, 1/4" lock washer, and a 1/4" washer.
- Snug tighten but allow for movement.

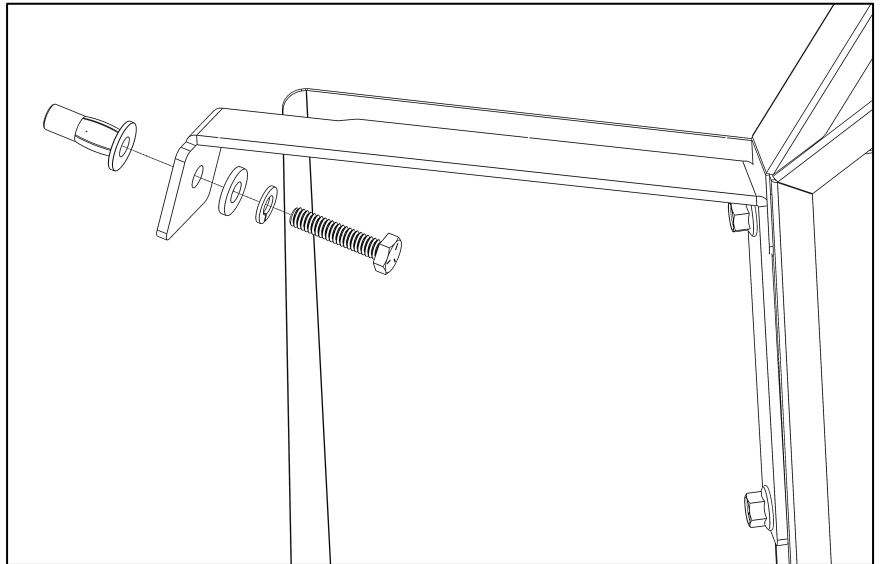

## **Step 11 – Installing Handle to Handle Bracket**

- From the backside, using two 5/16" x 1-1/4" carriage bolts, two 5/16" flat washers, and two 5/16" lock nuts, bolt through the rectangular slots in the previously installed handle mount, the passenger side wing, and then through factory handle.
- Snug tighten but allow for movement.

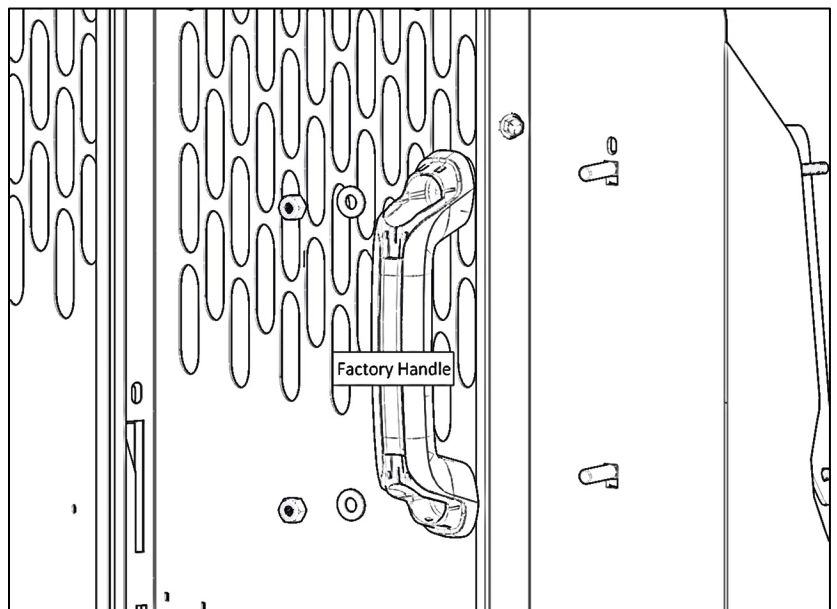



## Step 12 – Installing Wing to “B” Pillar



Always check that each location is clear of wires, fuel tanks and lines, air bags, and other important vehicle functionality items prior to installing screws into “B” pillar.

- Screw passenger side wing into “B” pillar using four #14 x 3/4” sheet metal screws.

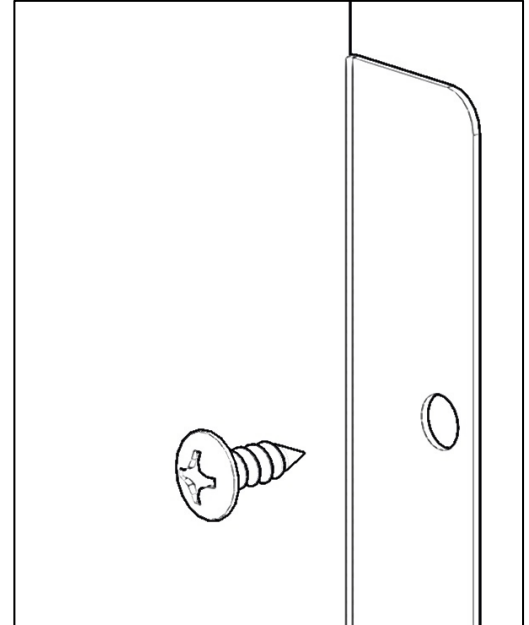
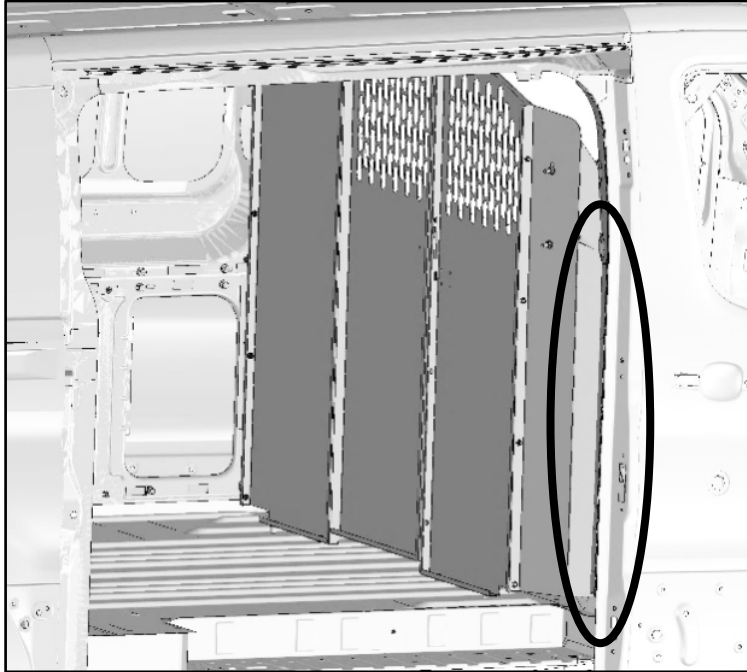

- If your vehicle came with factory-installed D-rings, reinstall D-rings through large holes in the bottom panel.
- If your vehicle did NOT come with factory-installed D-rings, install a 7/16” x 1-1/4” hex head bolt, 7/16” lock washer, and 7/16” flat washer through the large holes in the bottom panel.

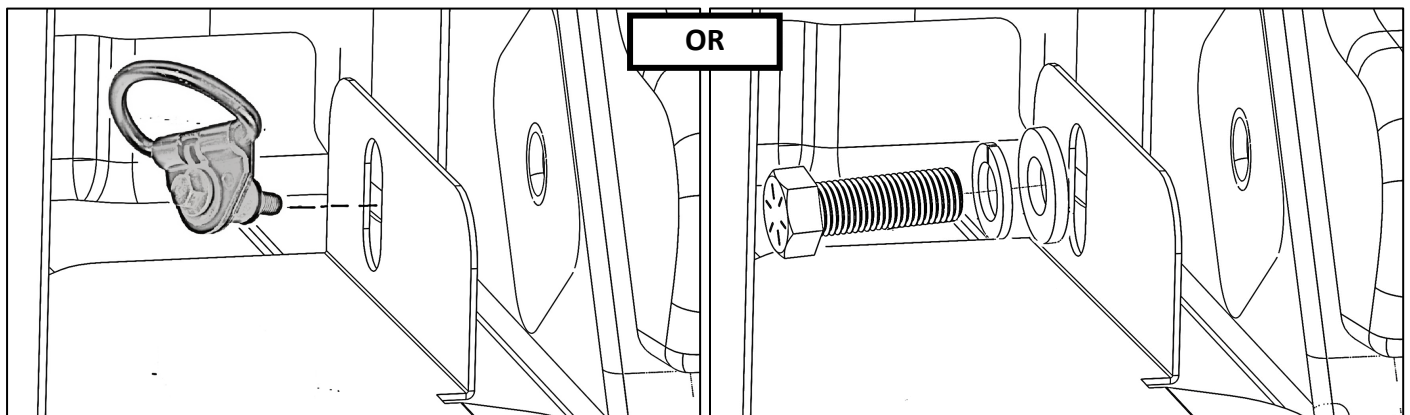

**GO BACK AND TIGHTEN ALL BOLTS.**

**YOUR INSTALLATION IS NOW COMPLETE.**