

Holman

Instruction Guide

40821

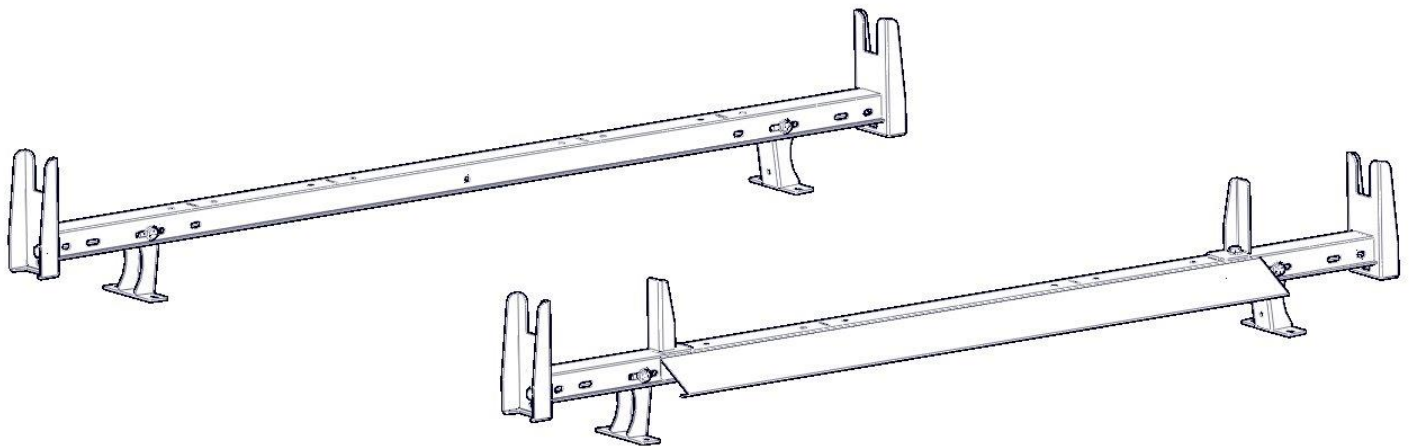

Holman
Rancho Cordova, CA 95742
800-343-7486

InstallationSupport@Holman.com

PLEASE READ ALL INSTRUCTIONS AND WARNINGS PRIOR TO ASSEMBLING, INSTALLING, AND USING THIS PRODUCT.

Warning



Always check for wires, fuel tanks and lines, brake lines and other important vehicle functionality items prior to drilling and installing all products.

Tools Needed

13mm Socket and Wrench	10mm Socket and Wrench
9/16" Socket and Wrench	

Table of Contents

Parts List	2
Assembly Hardware (18-40821-A)	3
Mount Hardware (18-40821-M)	4-5
Step 1 – Assemble Ladder Hooks	6
Step 2 – Assemble Wind Deflector	6
Step 3 – Location of Foot Mounts	7
Installation Instructions	
Transit Connect	8
Transit	9
Promaster City	10
NV200/Chevy City Express	11
Metris	12
NV	13
Sprinter	14
Promaster	15

Before You Begin



- Read all instructions.
- **Be sure to put sealant around all threads entering cargo area and between the rubber spacer and roof of vehicle to prevent water from leaking into cargo area.**
- **Ensure ALL hardware is tight at the conclusion of the instructions.**

NOTE: IF INSTALLING ON PROMASTER, 40918 KIT MUST BE PURCHASED AND INSTALLED.

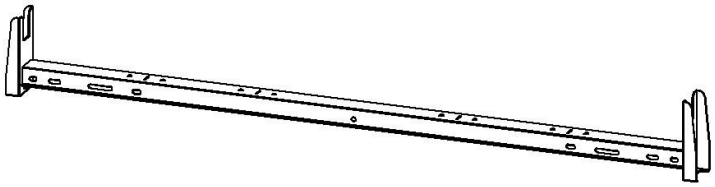
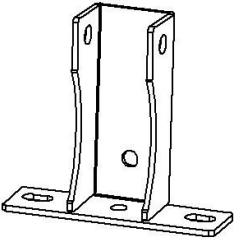
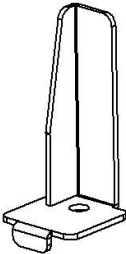
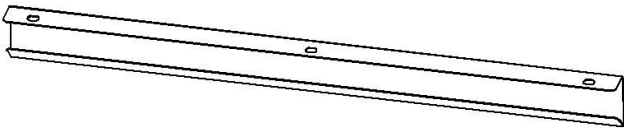



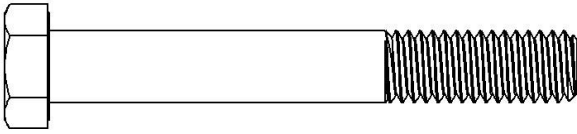
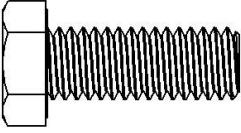
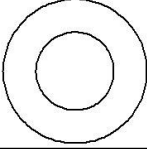
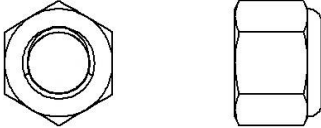

Parts

NO.	ITEM	PART NUMBER	DESCRIPTION	QTY.
1		40821-10	Crossbar Assembly	2
2		40821-10-001	Crossbar Rack Foot	4
3		40821-10-006	Ladder Hook	2
4		40821-10-009	Wind Deflector	1
5		18-40821-A	Assembly Hardware	1
6		18-40821-M	Mount Hardware	1

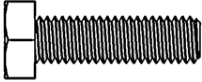

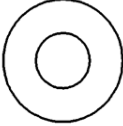
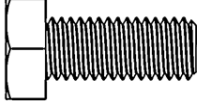
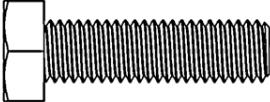
Assembly Hardware (18-40821-A)

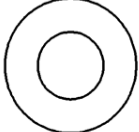
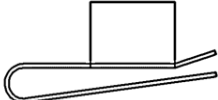
ITEM	HARDWARE TO SCALE	PART NUMBER	DESCRIPTION	QTY.
1		70114	3/8-16 X 2-3/4" HEX HEAD BOLT	4
2		70105	3/8-16 X 1" HEX HEAD BOLT	5
3		0174733	3/8" FLAT WASHER	18
4		70862	3/8"-16 NYLON INSERT LOCK NUT	9
5		40821-10-005	NYLON SPACER	4

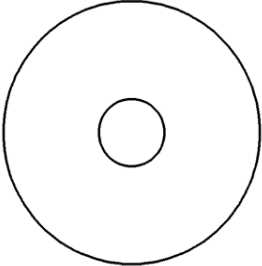
Installation Hardware (18-40821M)

ITEM	HARDWARE TO SCALE	PART NUMBER	DESCRIPTION	QTY.
1			M6 X 1.0 X 22MM HEX HEAD BOLT	8
2			1/4" SPLIT LOCK WASHER	8
3		90126A029	1/4" FLAT WASHER	8
4		91280A530	M8X1.25 X 20mm HH	8
5		91280A538	M8X1.25 X 30mm HH	4
6			5/16" LOCK WASHER	8
7		90126A030	5/16" FLAT WASHER	8
8		M8 U- NUT	M8 U-NUT	8
9		90576A117	M8X1.25 NYLOC	4
10			.312 FENDER WASHER	4

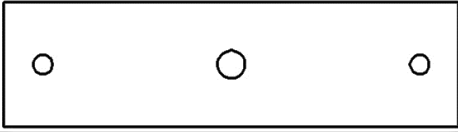
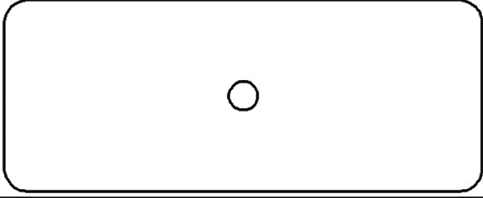
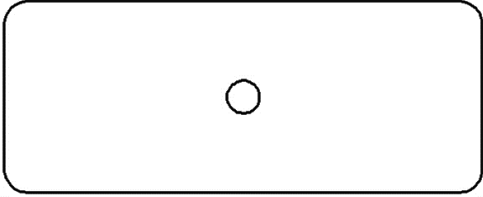
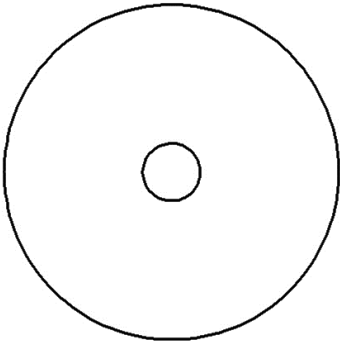
Installation Hardware (continued)

ITEM	HARDWARE TO SCALE	PART NUMBER	DESCRIPTION	QTY.
11		40821-10-004	3 HOLE RUBBER PAD	4
12		T249-02	RUBBER	4
13		T250-01	TRANSIT ROOF PLATE	4
14		-	1/8" X 5/16" X 1-3/4" RUBBER WASHER	4
15		SEALANT - 60 ML	SELF LEVELING ADHESIVE SEALANT	1

Step 1 – Assemble Ladder Hooks

- On one cross member, bolt two ladder hooks to the top of cross member using one 3/8" x 1" hex head bolt, two 3/8" flat washers, and one 3/8" lock nut. **Typically, this cross member goes to the front of the vehicle.**
- The tab on the ladder hook will line up with the slot in the cross member. The position of the tab is dependent on the width of your load.
- Tighten.

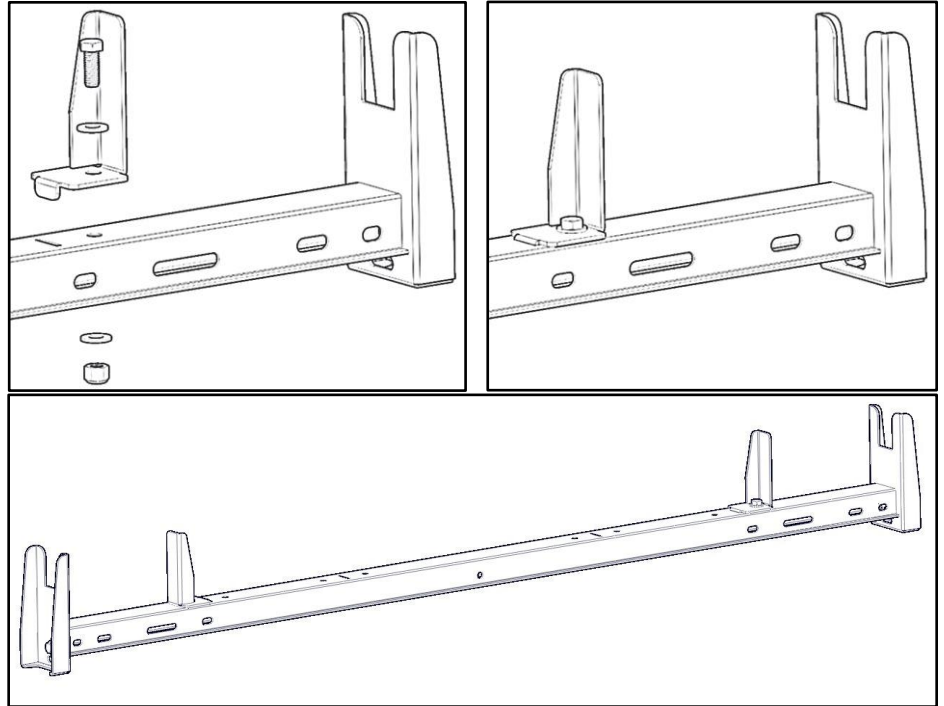

Step 2 – Assemble Wind Deflector

- Bolt wind deflector to the front of the cross member through the slot as shown below. **Typically this is attached to the same cross member with the ladder hooks**
- Use a 3/8" x 1" hex head bolt, a 3/8" flat washer, and a 3/8" lock nut in the order shown.
- Repeat in other two locations as shown.
- Square the wind deflector to the crossbar and tighten.

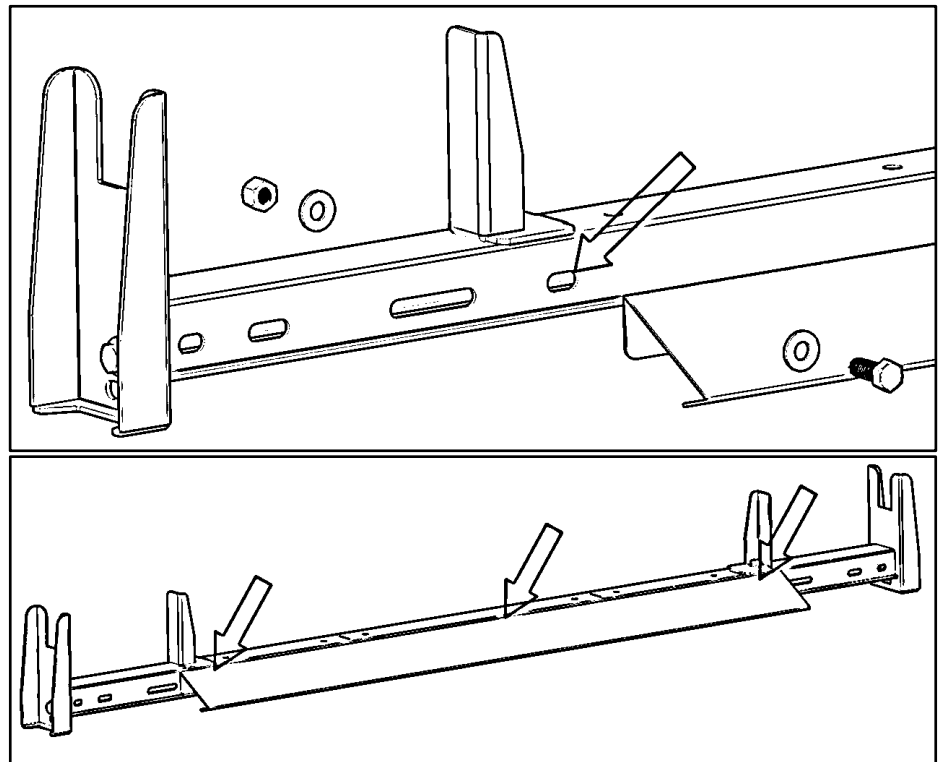

Step 3 – Assembly of Foot

NOTE: Depending on your vehicle, the foot will mount in different slots.

- Be sure to have the cup in the foot facing outward as shown for all vehicles except the low roof sprinter. The low roof Sprinter will need the cup in the foot facing inward.
- Use a 3/8" x 2-3/4" hex head bolt, two 3/8" flat washers, a nylon spacer, and a 3/8" lock nut to bolt foot to cross member. **Be sure to insert the nylon spacer inside foot.**
- Repeat on both sides and both cross members.
- **Do NOT tighten.**

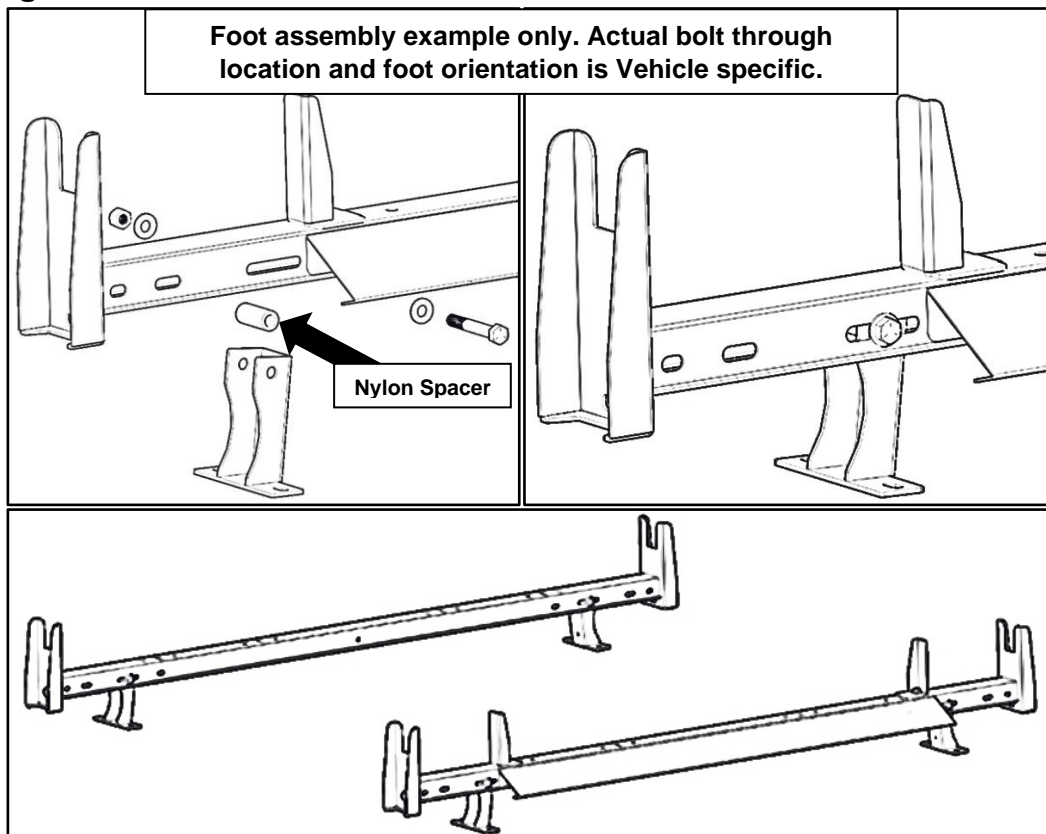
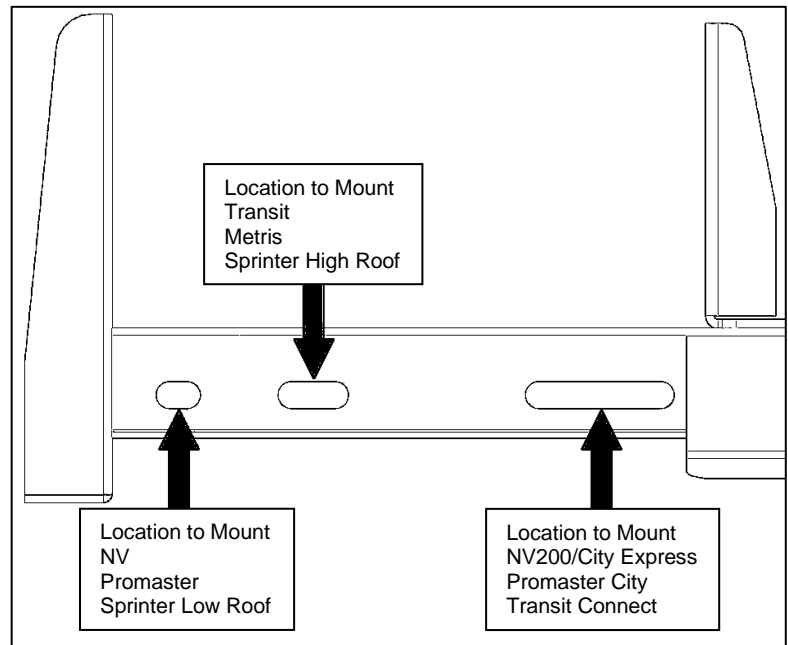

Installation Instructions

- The following are vehicle specific installation instructions. Follow the instructions for your specific vehicle.

Transit Connect

Step 4

- Locate 4 mounting locations in roof for the crossbars to be installed.
- Remove plugs from **ONLY** the desired mounting locations in roof. **Be sure that the spacing between the crossbars fit your shortest load.**

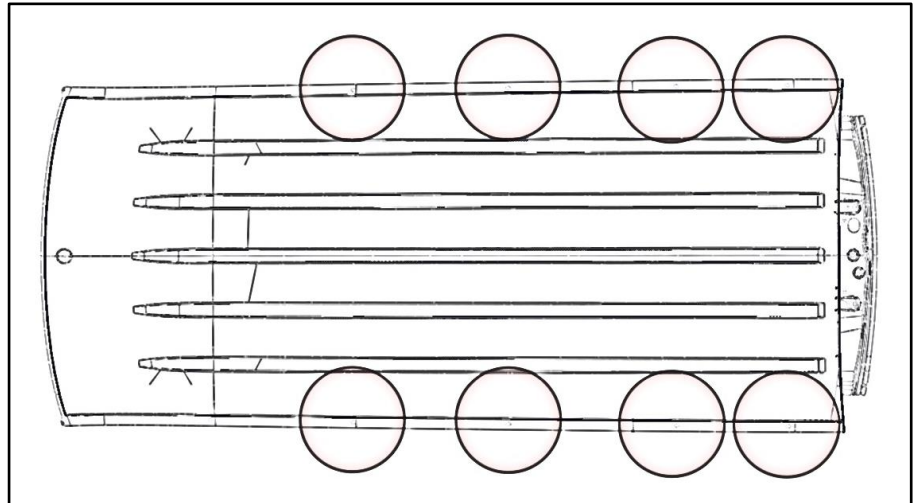

Step 5

NOTE: Be sure to put rubber spacer in between mount foot and roof of van as shown below. The roof goes in between rubber spacer and rubber washer.

- Place sealant between rubber spacer and roof of van and around threads to ensure no water leaks into van.
- Bolt through the mount foot into the exposed holes in roof using one M8 x 30mm hex head bolt, one 5/16" flat washer, a 3-hole rubber pad above roof, a rubber washer inside of roof, one 5/16" fender washer, another 5/16" flat washer, and one M8 lock nut, in that order, as shown.

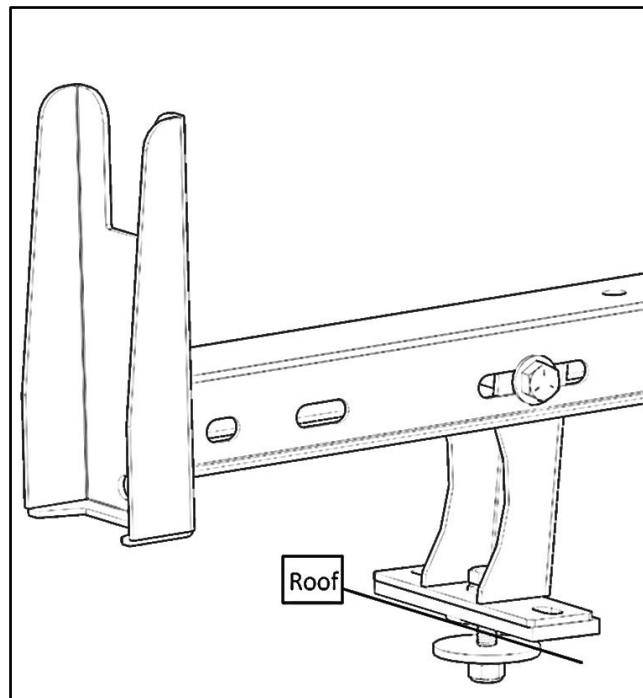
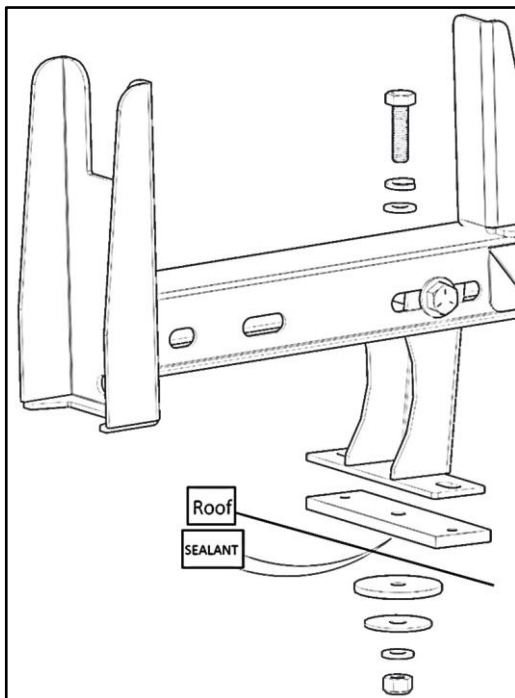

Step 6

- Go back and tighten all hardware including hardware on the rack itself.

Transit

Step 4

- Locate 4 mounting locations on roof for the crossbars to be installed.
- Remove plugs from **ONLY** the desired mounting locations in roof.

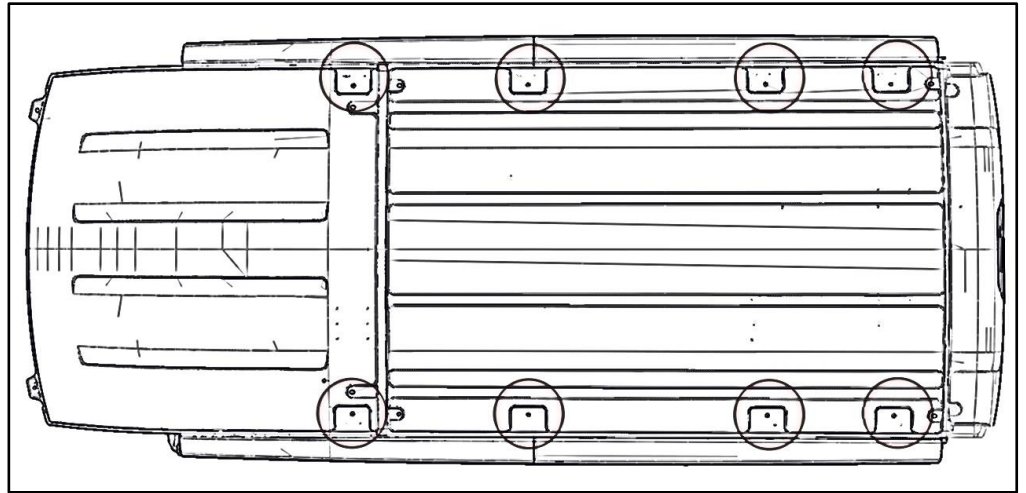

Step 5

NOTE: Be sure to put rubber pad and metal plate in between mount foot and roof of van as shown below. The rubber pad goes on the roof.

- Place sealant between rubber pad and roof of van and around threads to ensure no water leaks into van.
- Bolt through the mount foot into the exposed holes in roof using one M8 x 30mm hex head bolt, one 5/16" lock washer, one 5/16" flat washer, a metal plate, and a rubber pad, in the order shown.

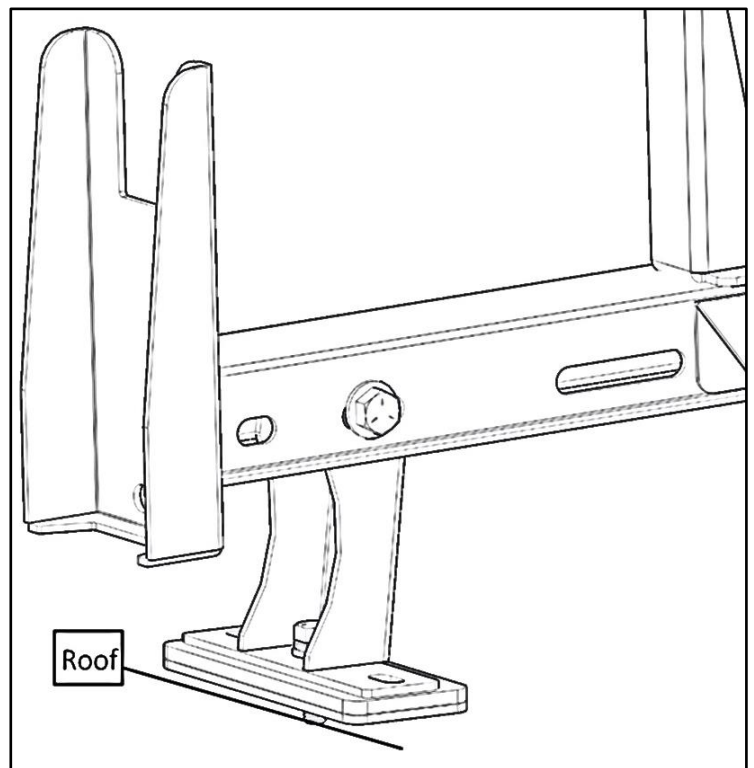
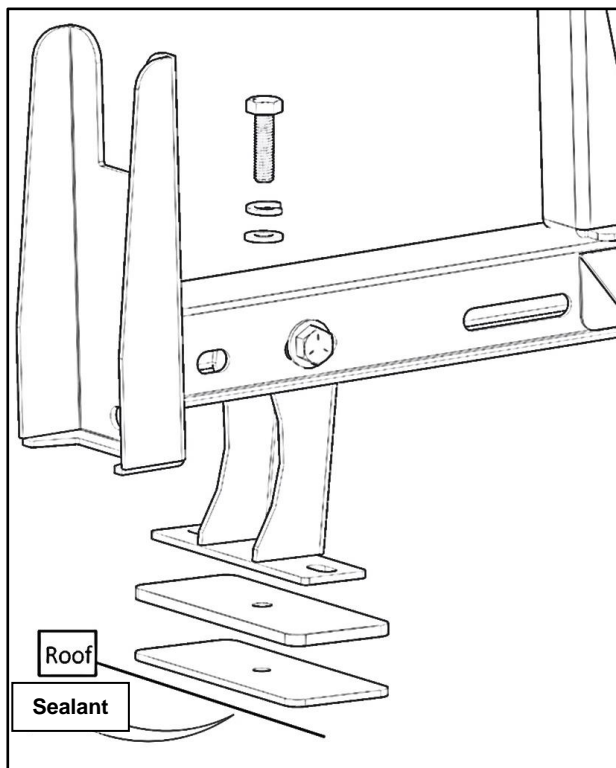

Step 6

- Go back and tighten all hardware including hardware on the rack itself.

Promaster City

Step 4

- Locate 4 mounting locations on roof for the crossbars to be installed.
- Remove plugs from **ONLY** the desired mounting location in roof.

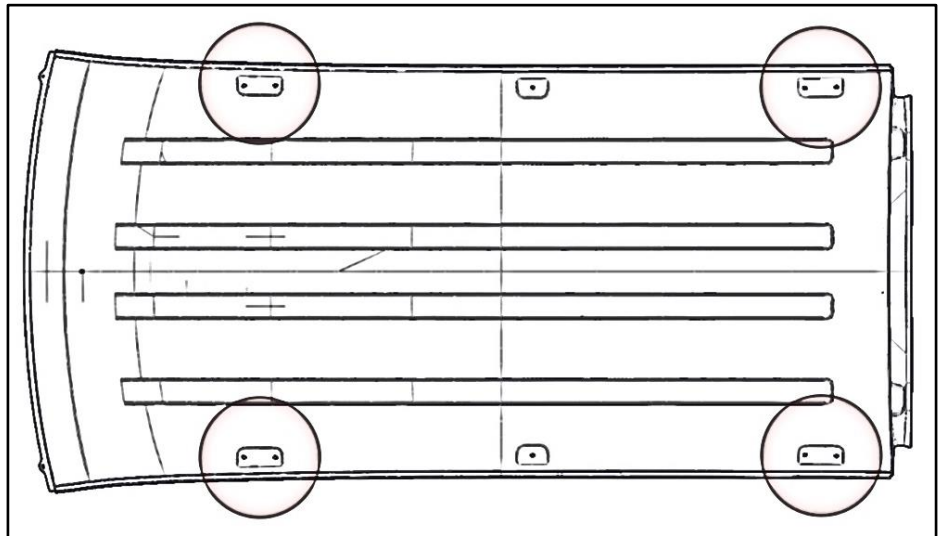

Step 5

NOTE: Be sure to put rubber spacer in between mount foot and roof of van as shown below.

- Place sealant between rubber spacer and roof of van and around threads to ensure no water leaks into van.
- Bolt through the mount foot into the exposed holes in roof using one M6 x 22mm hex head bolt, one 1/4" lock washer, one 1/4" flat washer, and a rubber spacer, in that order, as shown.

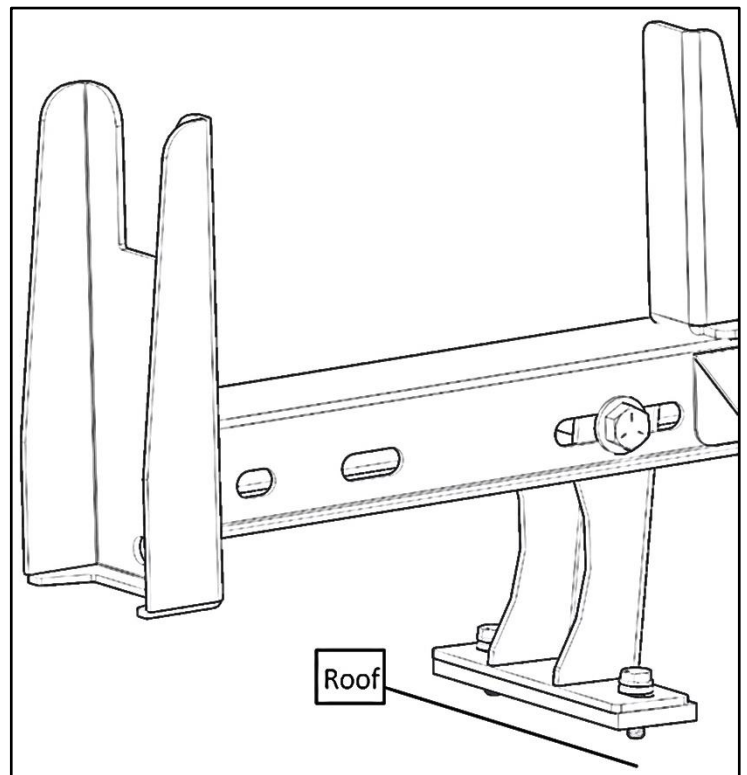
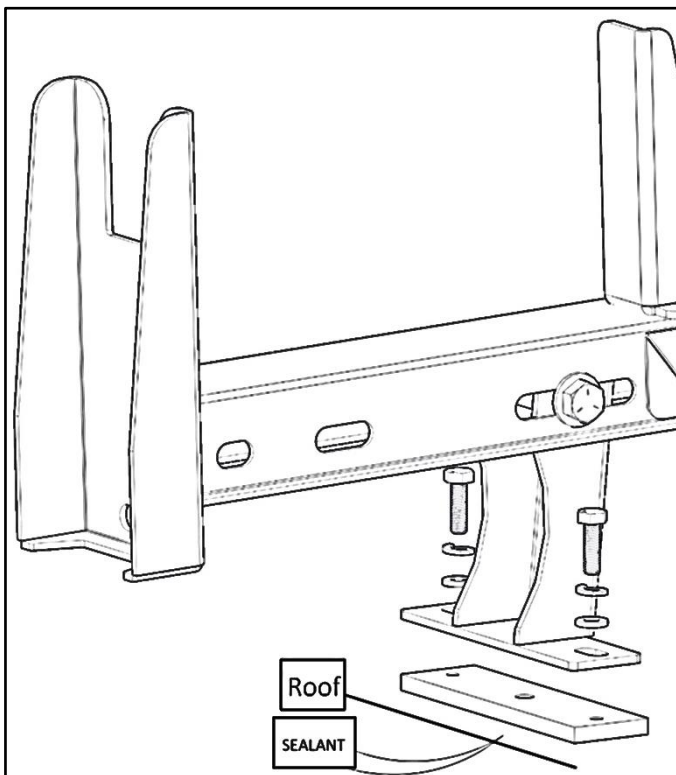

Step 6

- Go back and tighten all hardware including hardware on the rack itself.

NV200/Chevy City Express

Step 4

- Locate 4 mounting locations on roof for the crossbars to be installed.
- Remove plugs from **ONLY** desired mounting location in roof.

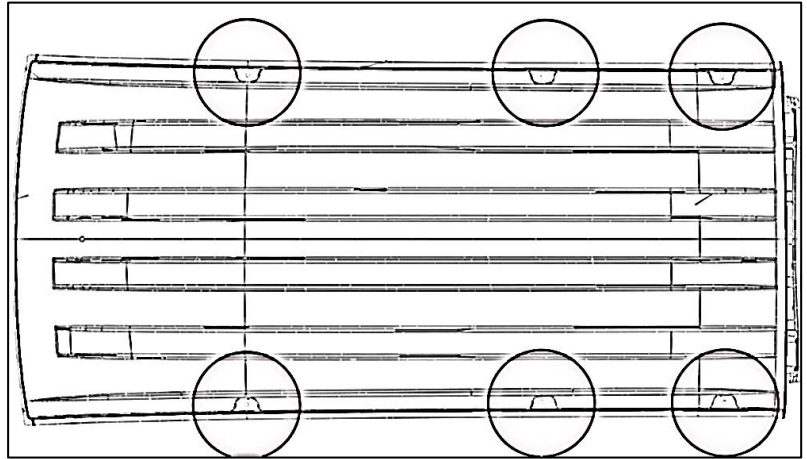

Step 5

NOTE: Be sure to put rubber washer in between mount foot and roof of van as shown below.

- Place sealant between rubber spacer and roof of van and around threads to ensure no water leaks into van.
- Bolt through the mount foot into the exposed holes in roof using one M8 x 30mm hex head bolt, one 5/16" lock washer, one 5/16" flat washer, and a rubber washer, in that order, as shown.

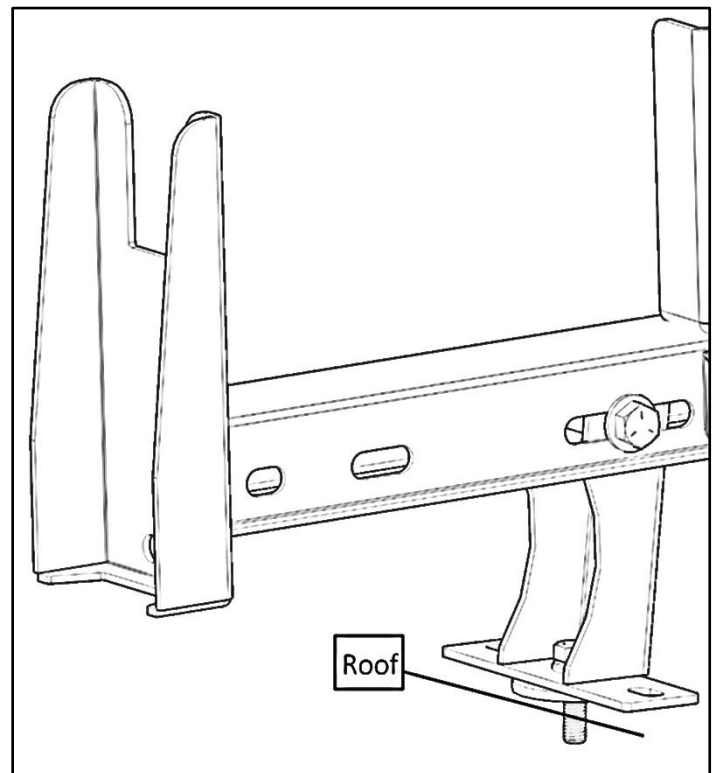
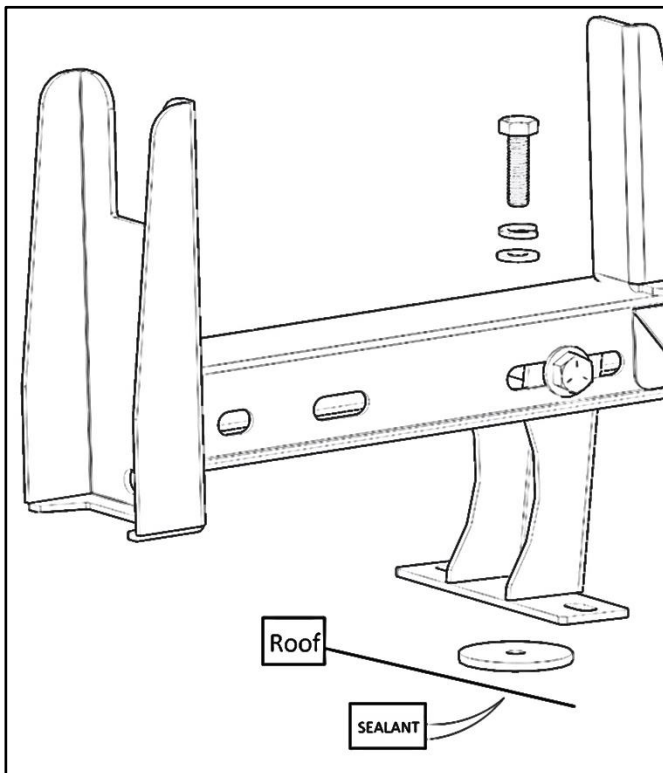

Step 6

- Go back and tighten all hardware including hardware on the rack itself.

Metris

Step 4

- Locate 4 mounting locations on roof for the crossbars to be installed.
- Remove plugs from **ONLY** the desired mounting location in roof.

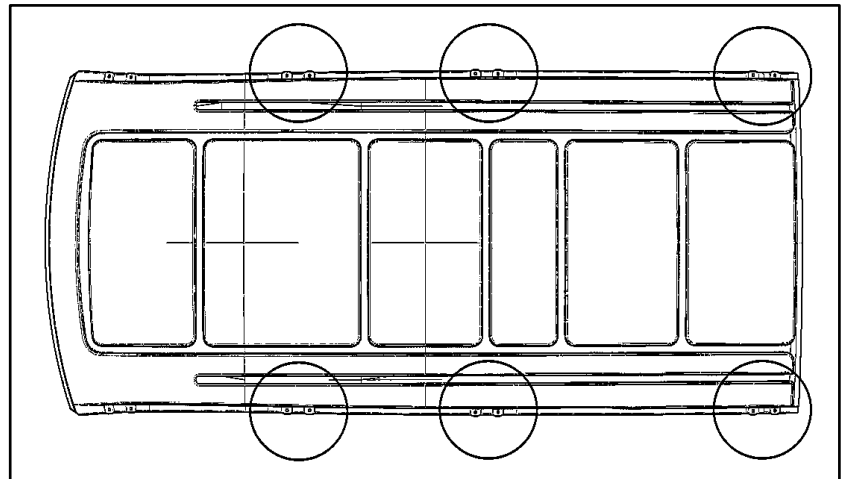

Step 5

NOTE: Be sure to put rubber spacer in between mount foot and roof of van as shown below.

- Place sealant between rubber spacer and roof of van and around threads to ensure no water leaks into van.
- Bolt through the mount foot into the exposed holes in roof using one M6 x 22mm hex head bolt, one 1/4" lock washer, one 1/4" flat washer, and a rubber spacer, in that order, as shown.

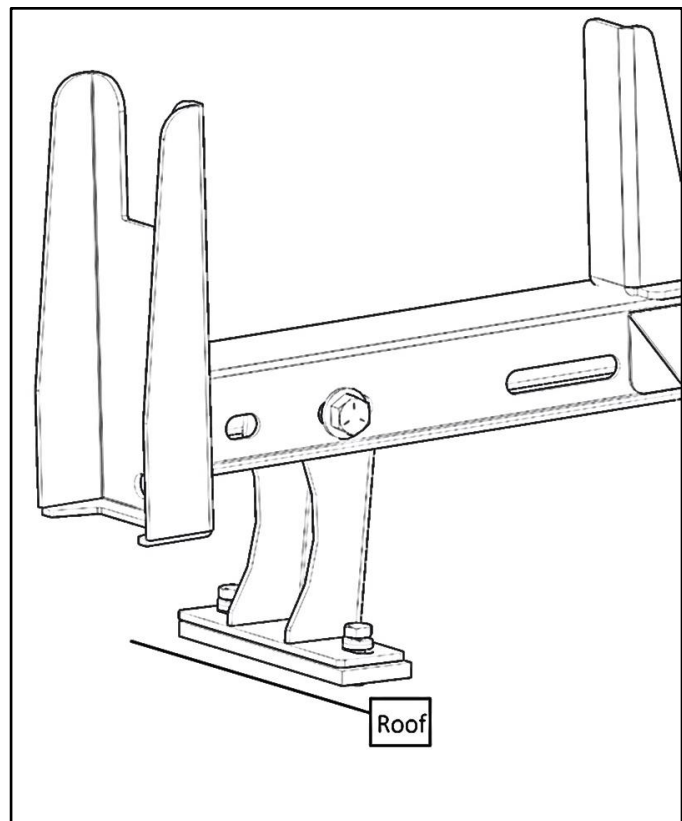
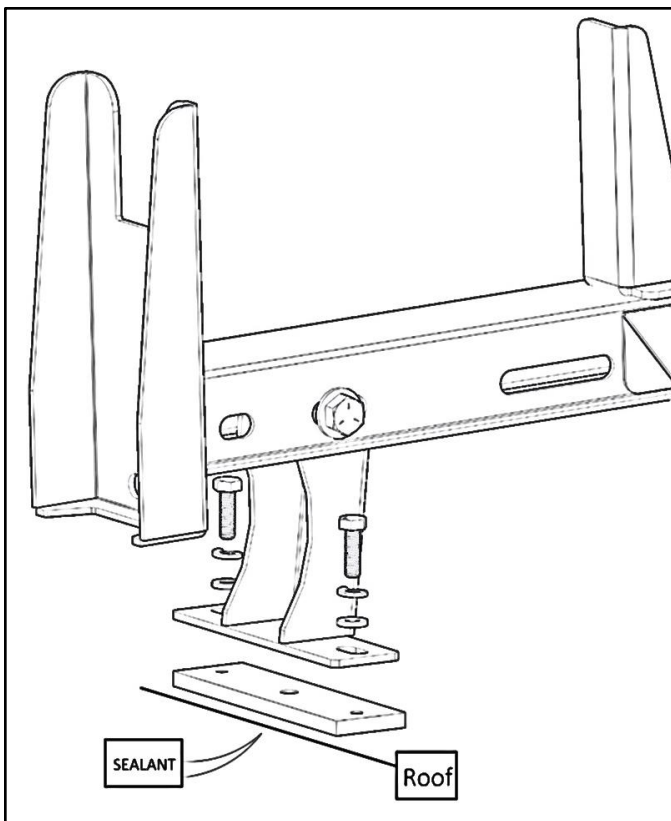

Step 6

- Go back and tighten all hardware including hardware on the rack itself.

NV

Step 4

- Locate 4 mounting locations on roof for the crossbars to be installed.

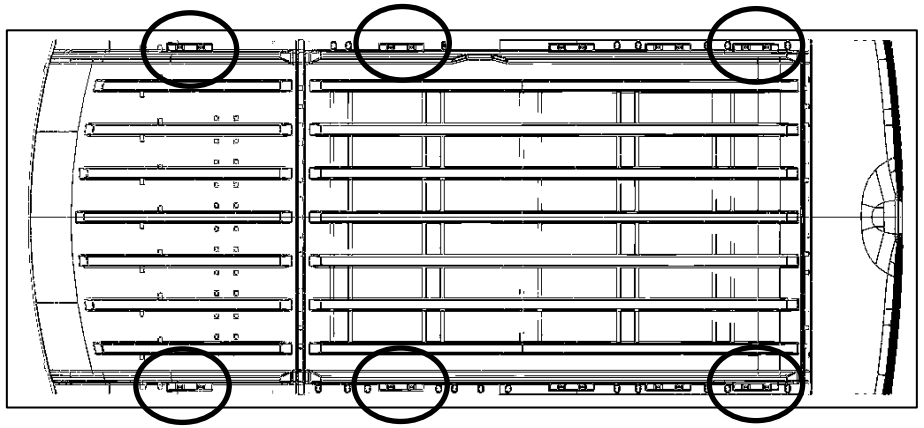

Step 5

- Install M8 U-nuts as shown.

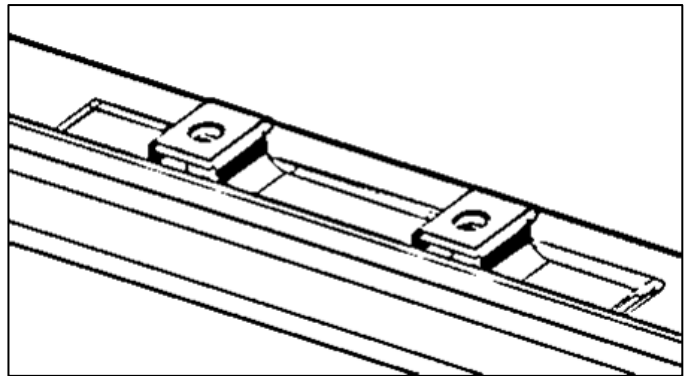
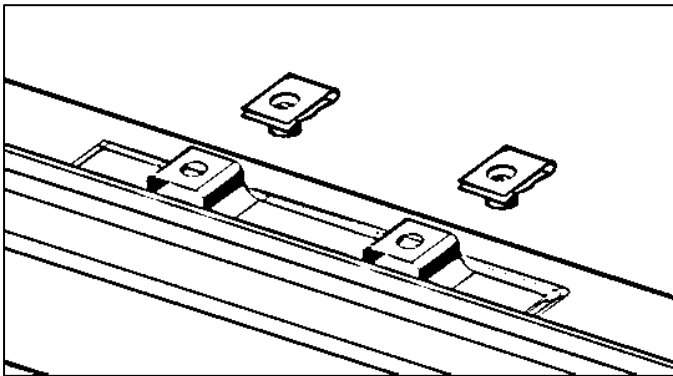

Step 6

- Bolt through the mount foot into the previously installed M8 U-nuts using M8 x 22mm hex head bolt, 5/16" lock washer, and 5/16" flat washer.

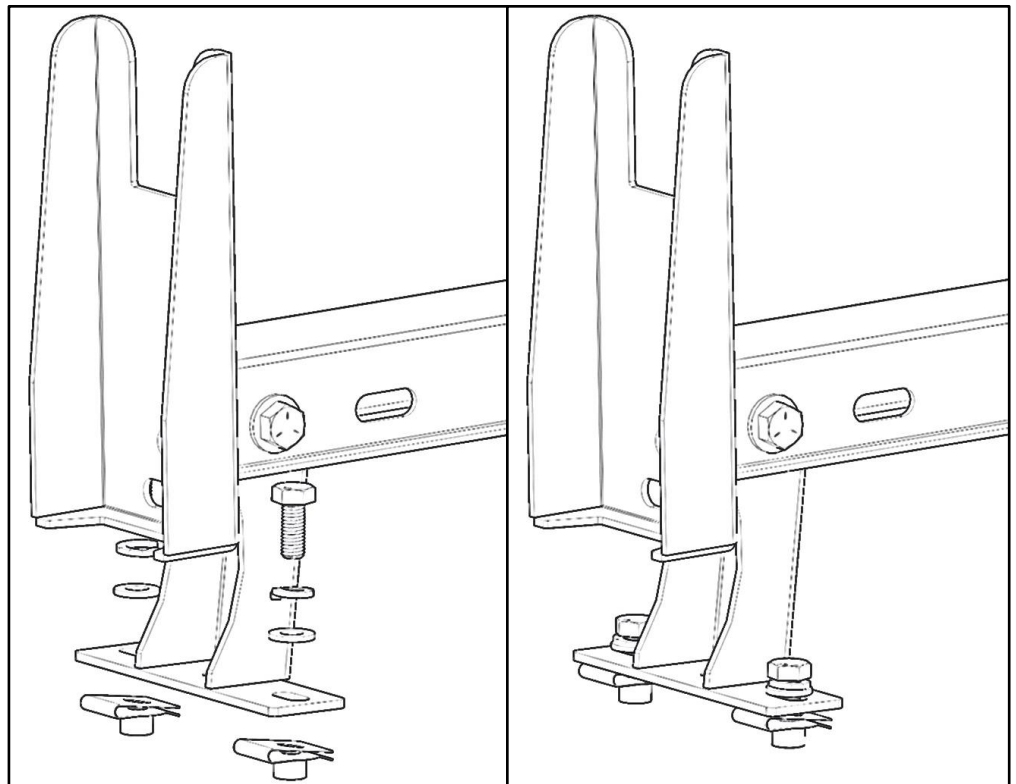

Step 7

- Go back and tighten all hardware including hardware on the rack itself.

Sprinter

Step 4

- Locate 4 mounting locations in roof for the crossbars to be installed.
- Remove plugs from **ONLY** desired mounting locations in roof.

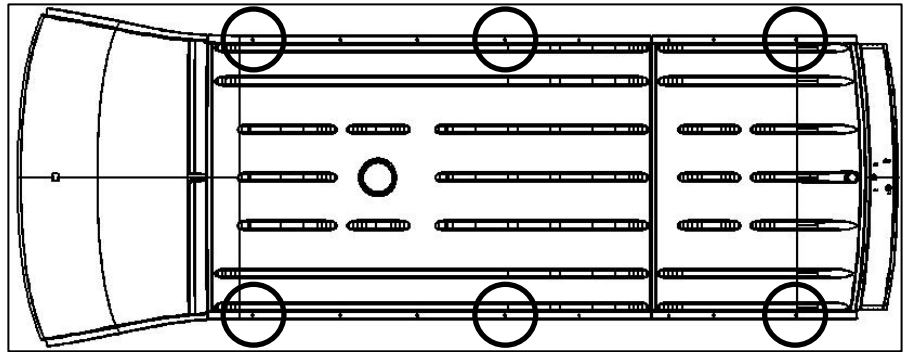

Step 5

NOTE: The low roof sprinter will need the cup in the foot facing inward.

NOTE: Be sure to put rubber spacer in between mount foot and roof of van as shown below. The roof goes in between rubber spacer and rubber washer.

- Be sure to place sealant between rubber spacer and roof of van and around threads to ensure no water leaks into van.
- Bolt through the mount foot into the exposed holes in roof using one M8 x 30mm hex head bolt, one 5/16" flat washer, a 3-hole rubber pad above roof, a rubber washer inside of roof, one 5/16" fender washer, another 5/16" flat washer, and one M8 lock nut, in that order, as shown.

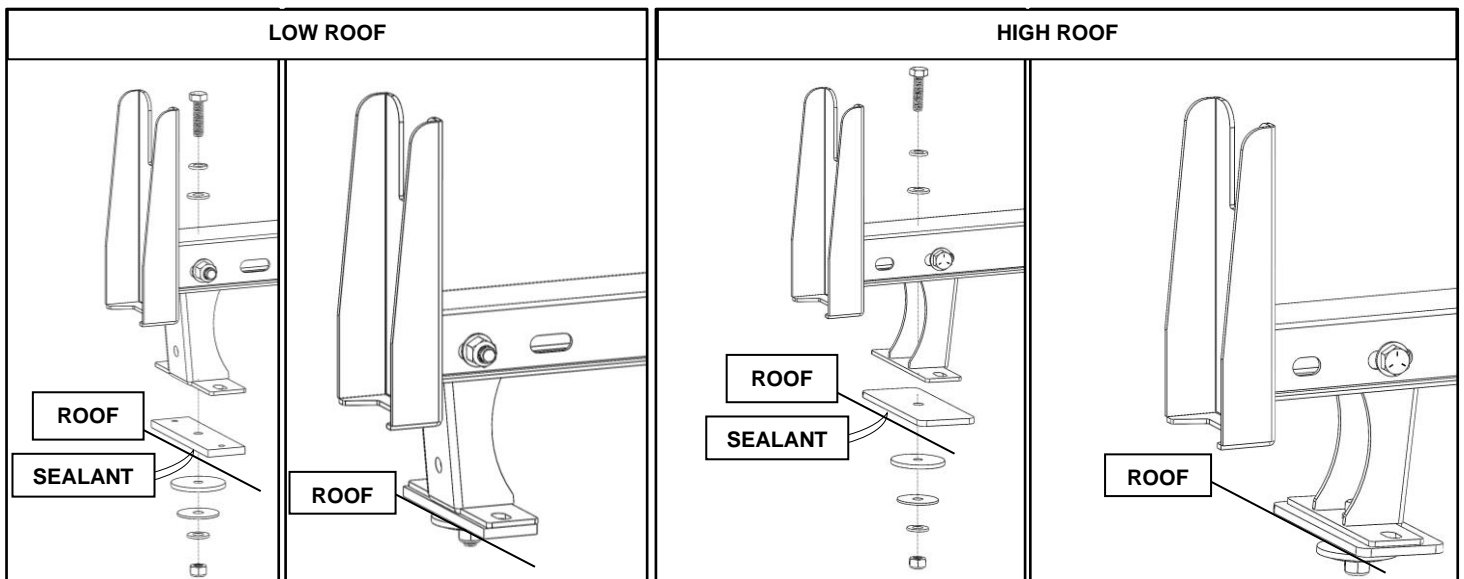

Step 6

- Go back and tighten all hardware including hardware on the rack itself.

ProMaster

Step 4

- Be sure to have 40918 preinstalled following the included instructions steps 1-3. Then return to this document and install per step 5 below.
- Discard the feet that come with 40918. The feet included in 40821 will be used instead.

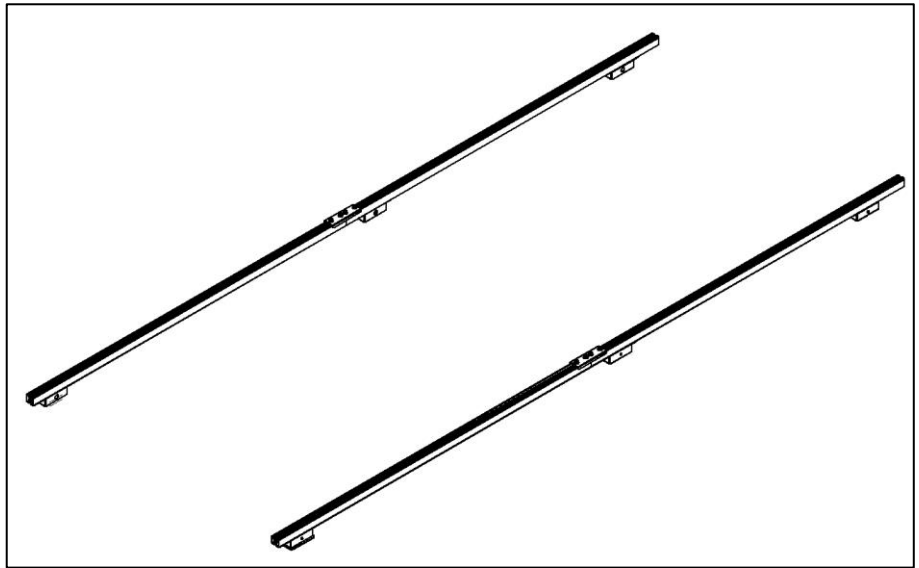

Step 5

- For each foot, slide two 5/16" x 3/4" carriage bolts into the top slot of the extrusion.
- Set foot onto extrusion aligning carriage bolts with mounting blocks.
- Using two 5/16" washers and 5/16" lock nuts, bolt extrusion to mounting blocks.
- Snug tighten but allow for movement.

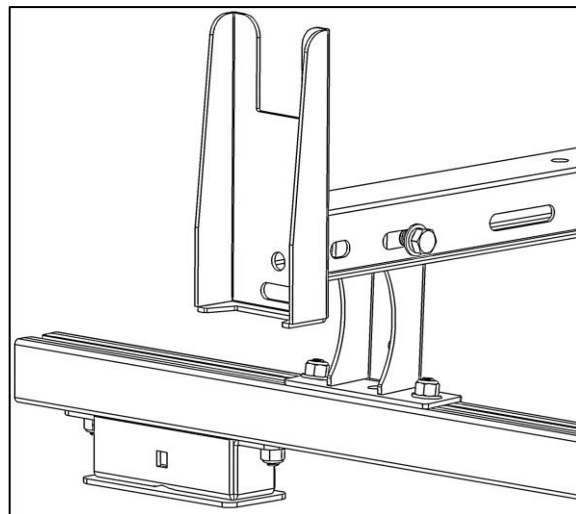
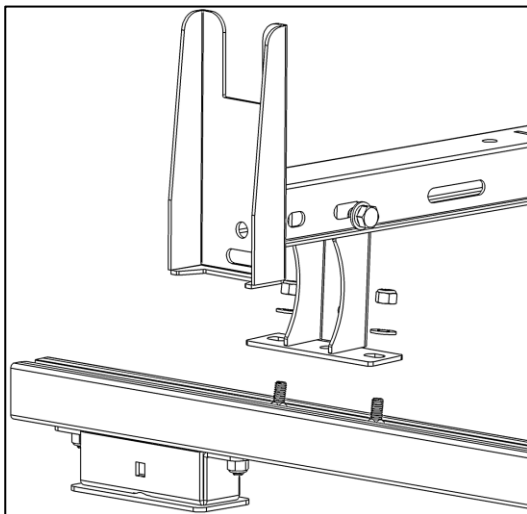

Step 6

- Go back and tighten all hardware including hardware on the rack itself.

GO BACK AND TIGHTEN ALL HARDWARE.

INSTALLATION AND ASSEMBLY ARE COMPLETE.