

Holman

Instruction Guide 8008A

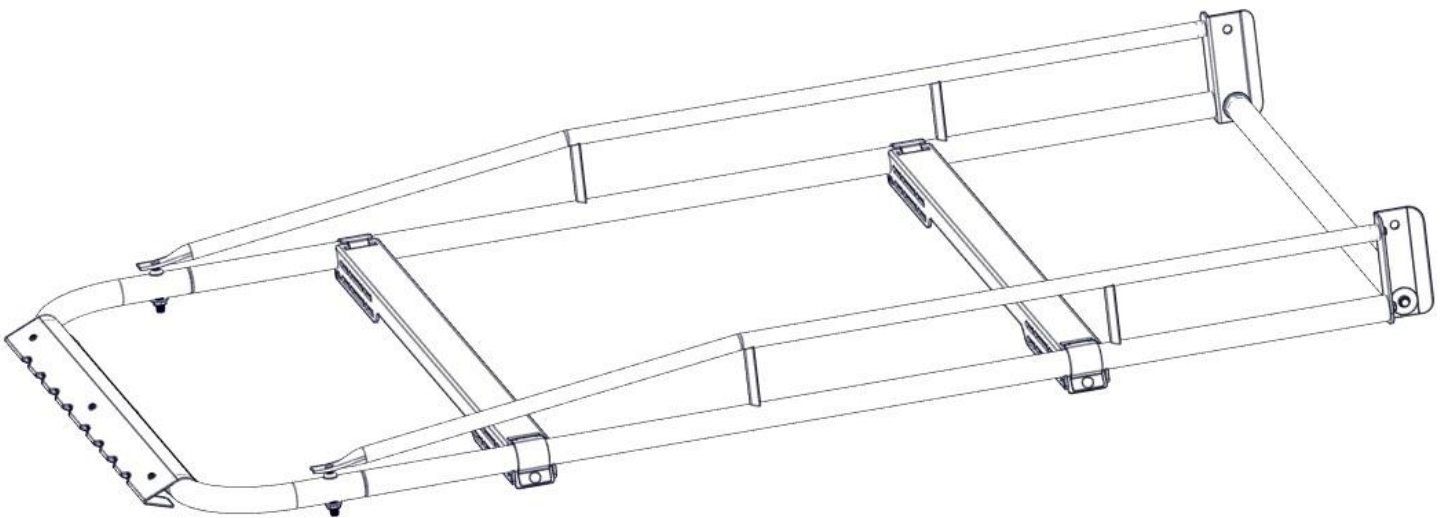

Holman
Rancho Cordova, CA 95742
800-343-7486
InstallationSupport@Holman.com

PLEASE READ ALL INSTRUCTIONS AND WARNINGS PRIOR TO ASSEMBLING, INSTALLING, AND USING THIS PRODUCT.

Warning



DO NOT EXCEED MANUFACTURERS WEIGHT CAPACITY FOR ROOF.



Secure all payloads properly for safe transportation.

Tools Needed

7/16", 1/2", 9/16", 3/4" Socket and Wrench	7/16", 1/2", 9/16", 3/4" Box Wrenches
#2 Philips Screwdriver	3/8" Hex Key Allen Wrench

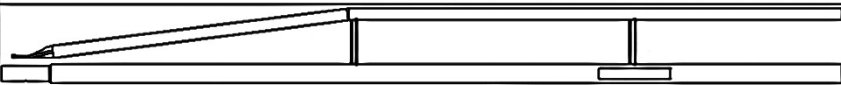
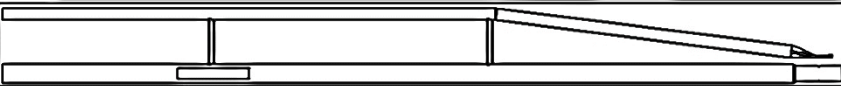

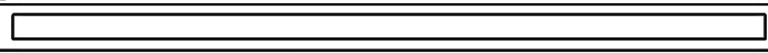

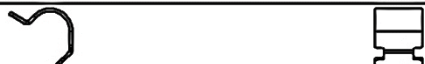
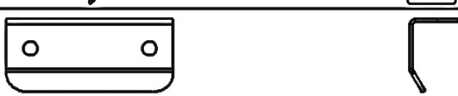

Table of Contents

Before You Begin	1
Parts	2
Hardware (18-8008A)	2
Hardware (18-8000A-RB)	4
Step 1 – Attach Roller Bar to Roller Bar Brackets	5
Step 2 – Attach Wind Deflector to Front Crossbar	5
Step 3 – Install Crossbars To Feet	6
Step 4 – Attach Side Channels to Crossbars.....	7
Step 5 – Attach Front Crossbar	7
Step 6 – Attach Roller Bar Assembly.....	8

Before You Begin

- Read all instructions prior to assembling or installing any Holman product.
- Always locate your installation locations prior to performing any work.
- **Be sure to put sealant around all threads entering cargo area and between the rubber spacer and roof of vehicle to prevent water from leaking into cargo area.**
- **HAVE THE MOUNTING KIT INSTALLED TO VEHICLE PRIOR TO INSTALLING THIS RACK.**
- **PROPER SEALANT APPLICATION IS CRITICAL TO PREVENTING WATER PENETRATION INSIDE THE RACK.** Apply a healthy bead of sealant entirely around every swaged joint and every bolt going through tubing. Improper sealing can lead to water penetration and rust on inside surfaces.



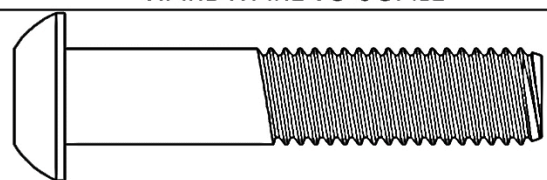
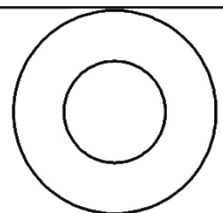

Parts

NO	ITEM	PART NUMBER	DESCRIPTION	QTY
1		102000	FRONT SIDE CHANNEL, DS	1
2		102001	FRONT SIDE CHANNEL, PS	1
3		8000A-005	50" FRONT TUBE	1
4		8000A-05	50" ROLLER BAR	1
5		8000A-06	50" CROSSBAR WELDMENT	2
6		8000A-010	SIDE CHANNEL CLAMP	4
7		8000A-019	ROLLER BAR BRACKET, COMPACT VAN	2
8		101699	WIND DEFLECTOR	1
9		8000A-017	WIND DEFLECTOR CLAMP	3
10		18-8008A	ASSEMBLY BOLT KIT	1
11		18-8000A-RB	ROLLER BAR BOLT KIT	1
12		18-31571	HARDWARE KIT	1

Hardware (18-8008A)

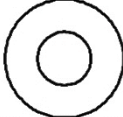
ITEM	HARDWARE TO SCALE	PART NUMBER	DESCRIPTION	QTY.
1			.50 X 2.5" BUTTON HEAD	2
2		11541086	1/2" WASHER	2

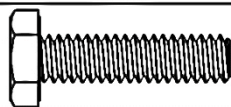
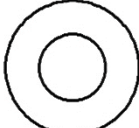
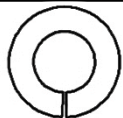
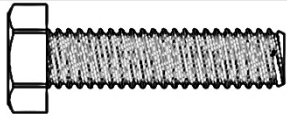
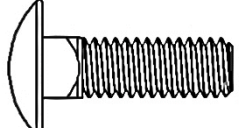
Hardware (18-8008A) (Continued)

ITEM	HARDWARE TO SCALE	PART NUMBER	DESCRIPTION	QTY.
3		37695	1/2"-13 THIN LOCKING JAM NUT	2
4		33078	1/4" FLAT WASHER	2
5		33618	1/4" LOCK WASHER	2
6		13005	1/4-20 X 1" HEX HEAD BOLT	2
7		33006	5/16" FLAT WASHER	2
8		1133620	5/16" LOCKING WASHER	2
9		11241180	5/16-18 X 1-1/4" HEX HEAD BOLT	2
10		21811	5/16-18 X 1" CARRIAGE BOLT	4
11		11104019	5/16-18 FLANGED NYLOCK NUT	4
12		Sealant - 60 ml	SELF LEVELING ADHESIVE SEALANT	1

Hardware (18-8000A-RB)

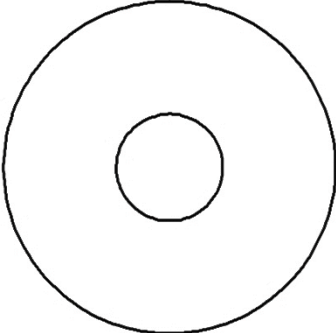
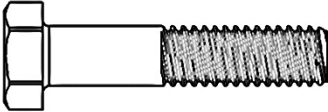
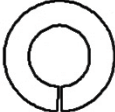
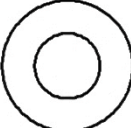
ITEM	HARDWARE TO SCALE	PART NUMBER	DESCRIPTION	QTY.
1		6391K406	OIL-EMBEDDED BRONZE SLEEVE BEARING	2
2		95611A287	CHEMICAL-RESISTANT PVC PLASTIC WASHER FOR 1/2" SCREW SZ, 0.562" ID, 1.75" OD, 0.053"-0.071" THK	4
3		11241181	5/16"-18 X 1-1/2" HEX HEAD BOLT	2
4		1171067	5/16" LOCKING WASHER	2
5		11545144	5/16" FLAT WASHER	2

Hardware (18-31571)

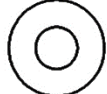
ITEM	HARDWARE TO SCALE	PART NUMBER	DESCRIPTION	QTY.
1		0149489	10-32 X 3/4" PAN HEAD SCREW	3
2		33074	#10 FLAT WASHER	3

Sealant Application

- Proper sealant application is critical to preventing water penetration inside the rack.
- Apply a healthy bead of sealant around every swaged joint as shown. Improper sealing can lead to water penetration and rust on inside surfaces.
- Wipe any excess sealant off immediately with a plastic scraper or paper towel. Any smeared sealant can be rubbed off as soon as sealant dries.
- Maintain this seal throughout the life of your rack.

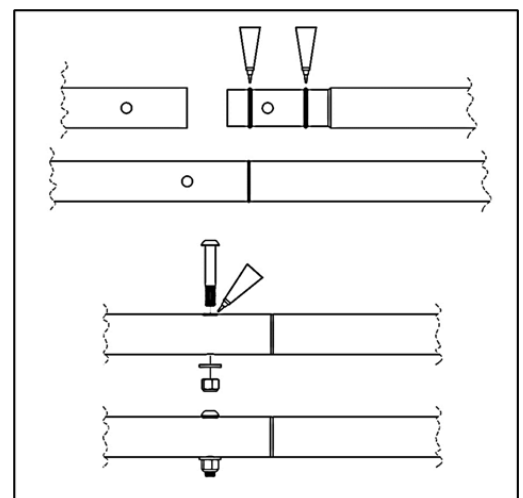

DO NOT EXCEED MANUFACTURERS WEIGHT CAPACITY FOR ROOF.

Step 1 – Attach Roller Bar to Roller Bar Brackets

Note: The center roller bar mounting position is best for load bearing. Several positions are provided to accommodate different loading positions.

- Using a 5/16" x 1-1/2" hex head bolt, bolt through the following and into the end of the roller bar.
 - a 5/16" lock washer,
 - a 5/16" flat washer,
 - two plastic washers (one on each side of roller bar bracket),
 - a roller bar bracket, and
 - a roller bearing,

Be sure flanges are facing away from each other and away from center of roller bar.

- Repeat for opposite side.

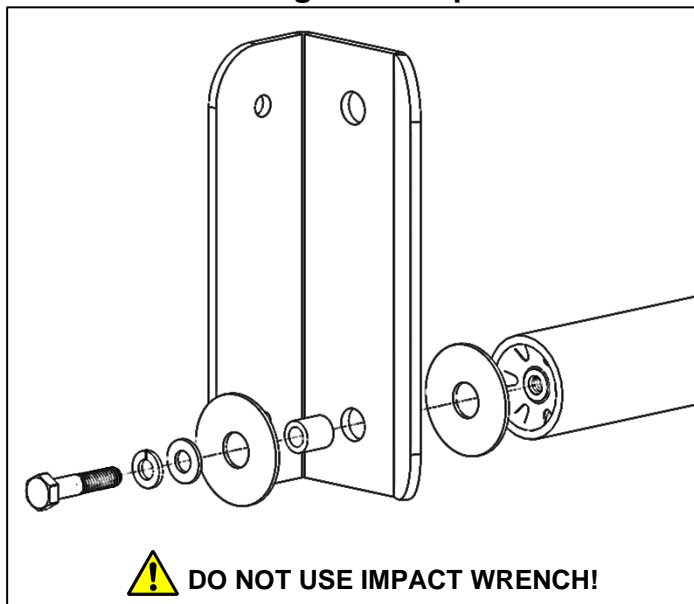

Step 2 – Attach Wind Deflector to Front Crossbar

- Insert wind deflector clamp-retainer into cutout in wind deflector.

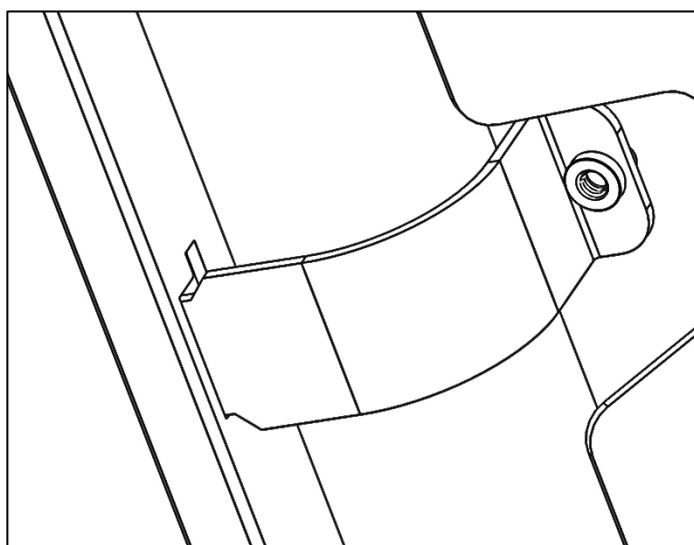
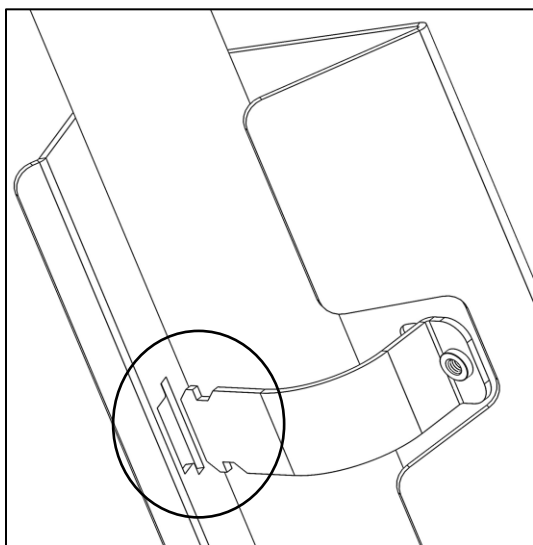

- Hold wind deflector in position with angled edge aimed towards front of vehicle.
- Use a #10 x 3/4" pan head screw and #10 washer to bolt through the wind deflector into the press nut in the clamp.
- Repeat for remaining two clamps.
- Tighten.

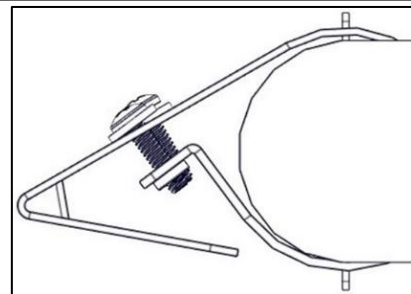

Step 3 – Install Crossbars To Feet

NOTE: HARDWARE TO ATTACH CROSSBARS TO FEET IS INCLUDED IN MOUNTING KIT.

- Set crossbar onto feet. Mounting feet may be installed into either upper or lower slots, based upon clearance required for vehicle.
- Center crossbar right-to-left with feet and vehicle.

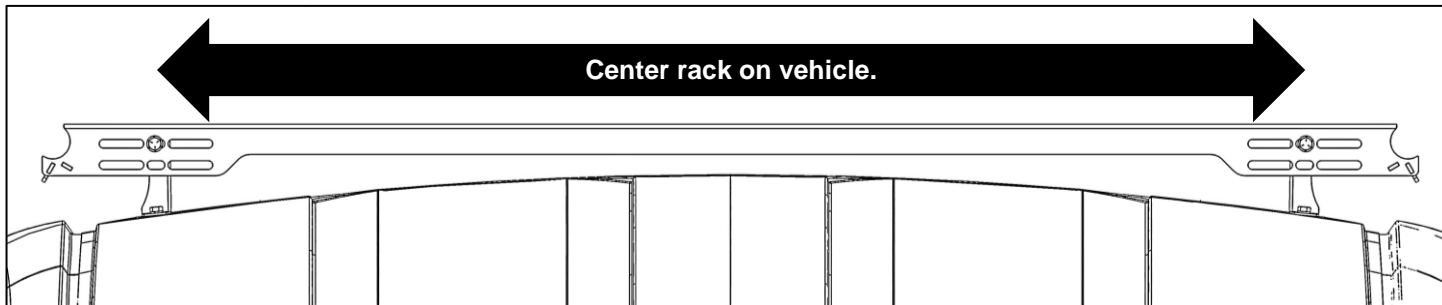

- Using 3/8" x 1" hex head bolts, 3/8" lock nuts, and 3/8" flat washers provided with mounting kit, bolt crossbar to feet.
- Tighten but allow movement.

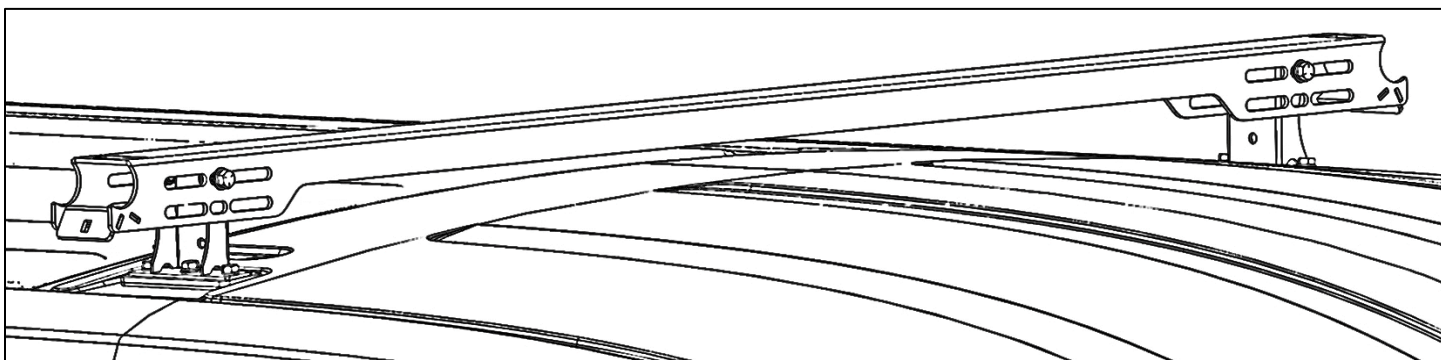
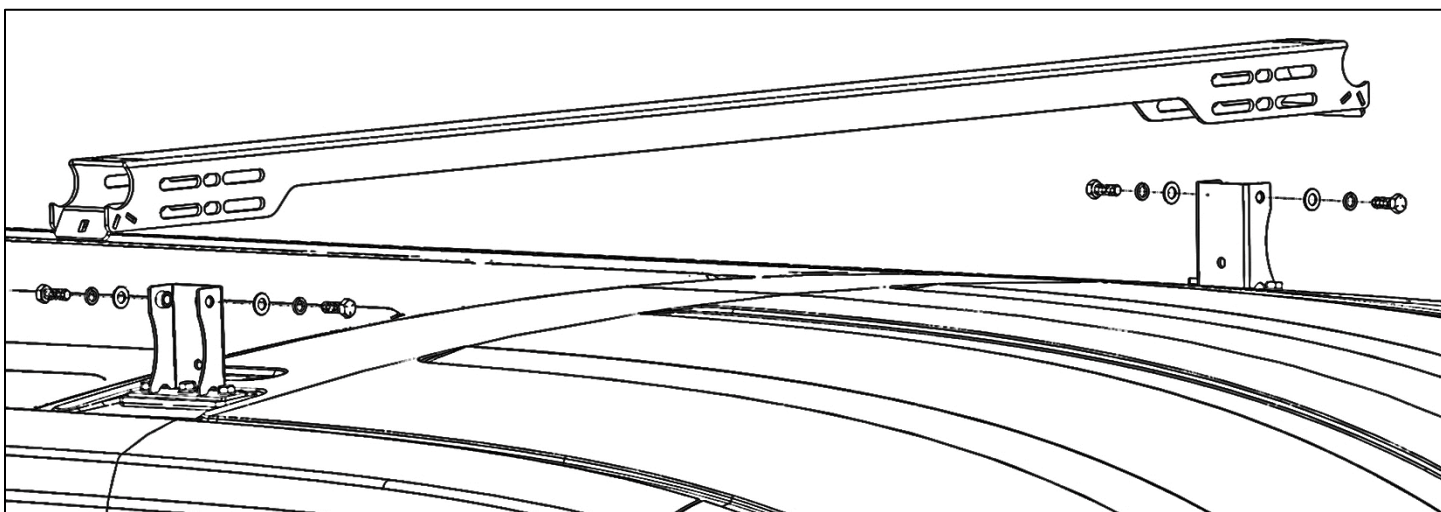

- Repeat for all remaining crossbars.

Step 4 – Attach Side Channels to Crossbars

- Identify driver-side and passenger-side front side-channels. Decals should face away from vehicle.
- Set side channel into round cutout in crossbars in desired position.
- Although rack position may be adjusted later, it is recommended to determine the front-to-back position of the rack at this point.
- Insert a side channel clamp into cutout in each crossbar with interior diameter facing upward.

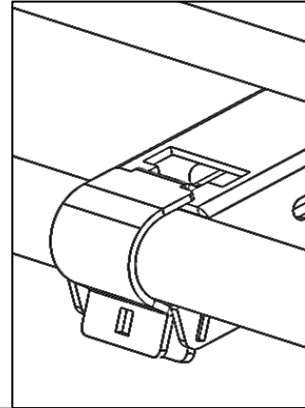
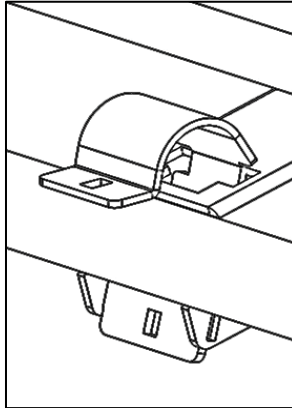
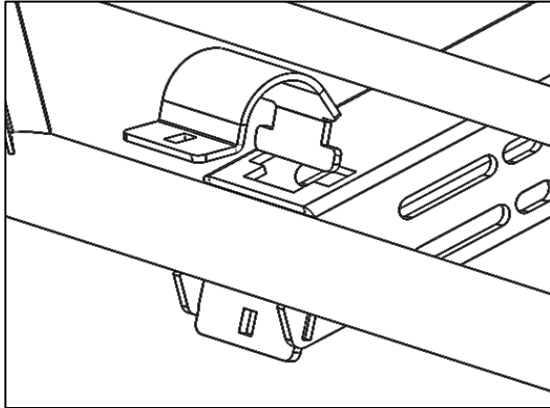

- For each side channel clamp, use a 5/16" x 1" carriage bolt and 5/16" flanged lock nut to bolt side channel clamp to crossbar.
- Snug Tight but allow for movement.

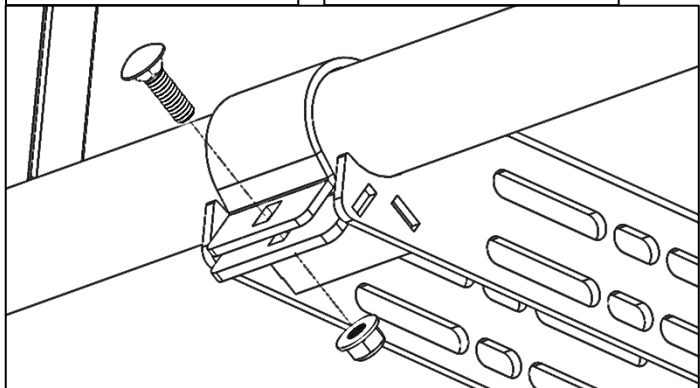

Step 5 – Attach Front Crossbar

- Cover swage joints with sealant per Sealant Application guidelines. Push front crossbar onto swaged end of side channel. **Be sure to align holes in both and be sure flat face of wind deflector is on top.**
- Using a 1/2" x 2-1/2" button head cap screw, 1/2" flat washer, and 1/2" locking jam nut, bolt through front of side channel and front crossbar.
- Tighten.
- Repeat for opposite side.

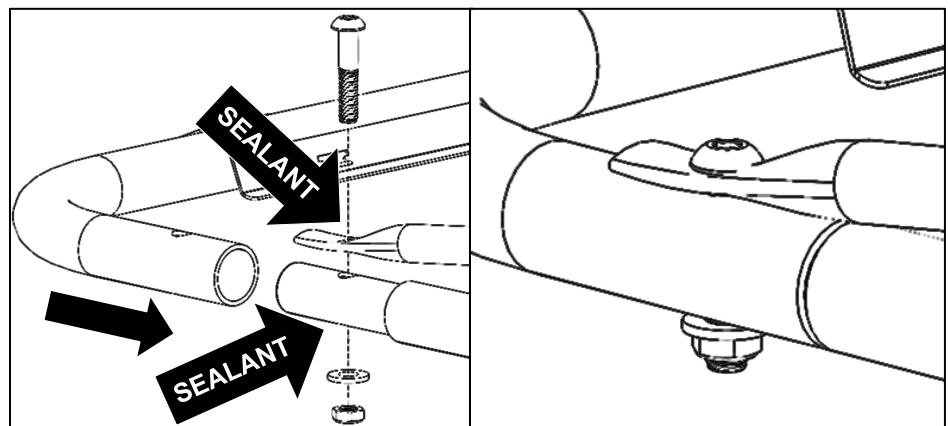

Step 6 – Attach Roller Bar Assembly

- Using a 1/4" x 1" hex head bolt, 1/4" lock washer, and 1/4" flat washer, bolt through the TOP hole in the roller bar bracket into end of TOP of side channel.
- Using a 5/16" x 1-1/4" hex head bolt, 5/16" lock washer, and 5/16" flat washer, bolt through the BOTTOM holes in the roller bar bracket into end of BOTTOM of side channel.
- LOOSELY tighten hardware.
- Repeat for opposite side.
- **Check that the rack is square to the vehicle and mounts.**

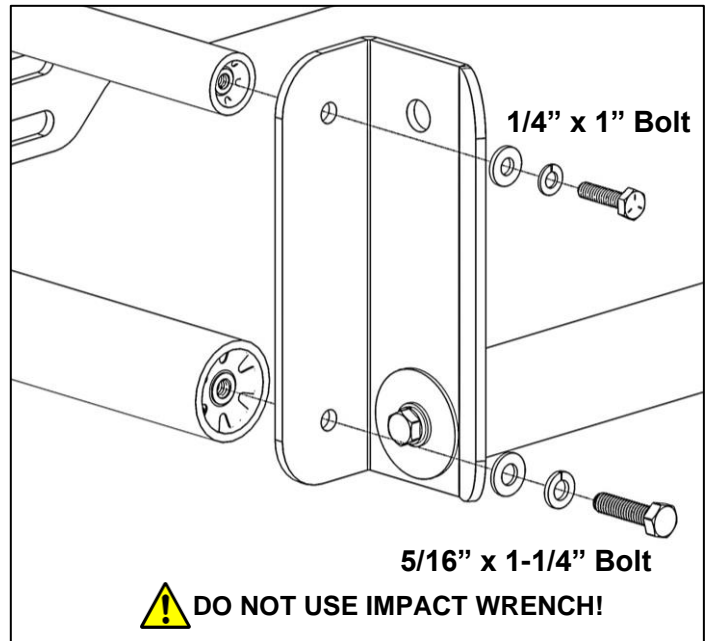

- **Be sure the rear roller bar is hanging off the rear of the vehicle enough so that when placing a ladder on the rack, it does not come into contact with the rear of the vehicle.**

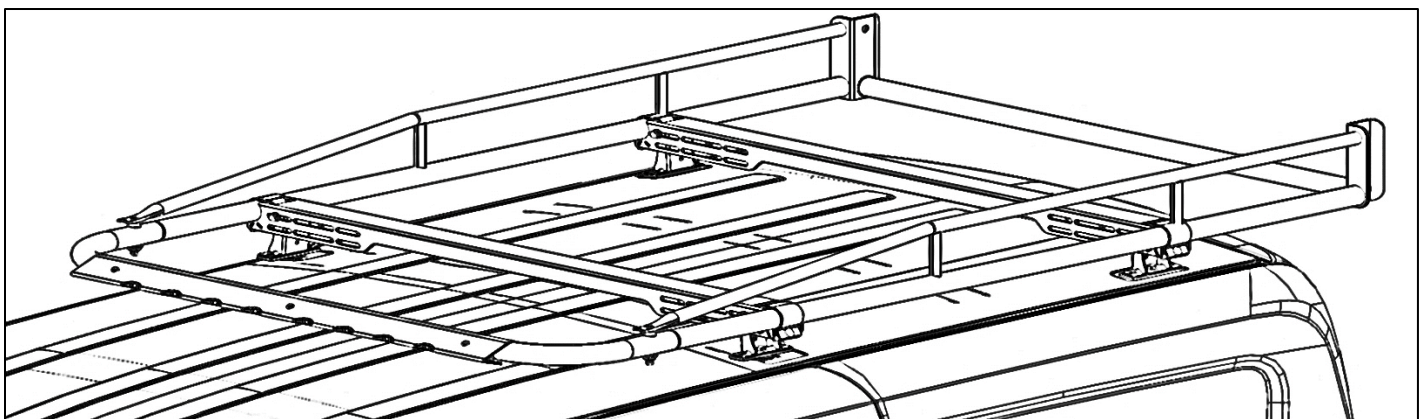
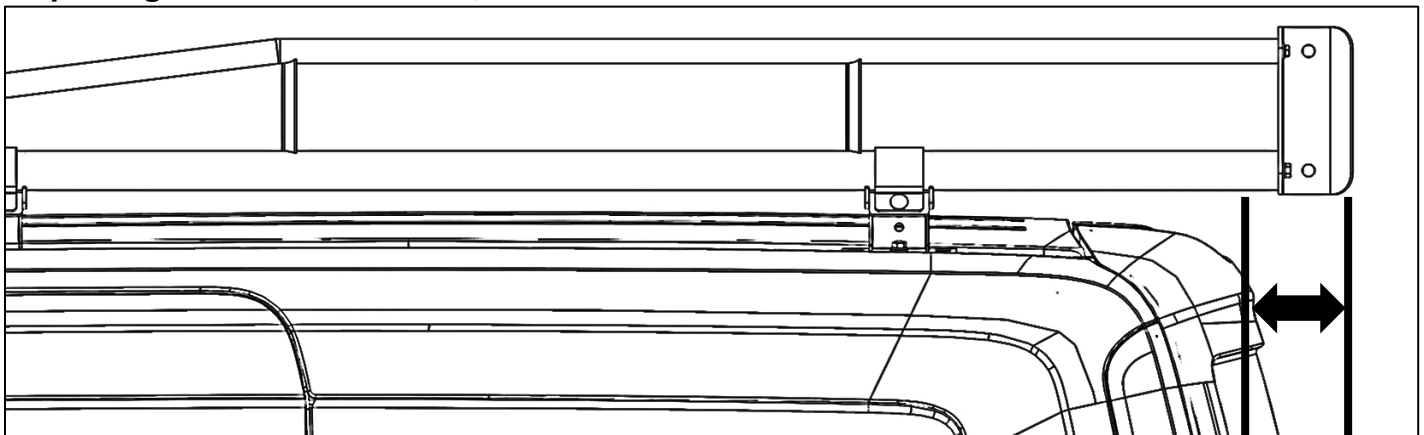

GO BACK AND TIGHTEN ALL HARDWARE.

INSTALLATION AND ASSEMBLY ARE COMPLETE.