

# Holman

---

## Instruction Guide Folding Shelves

---

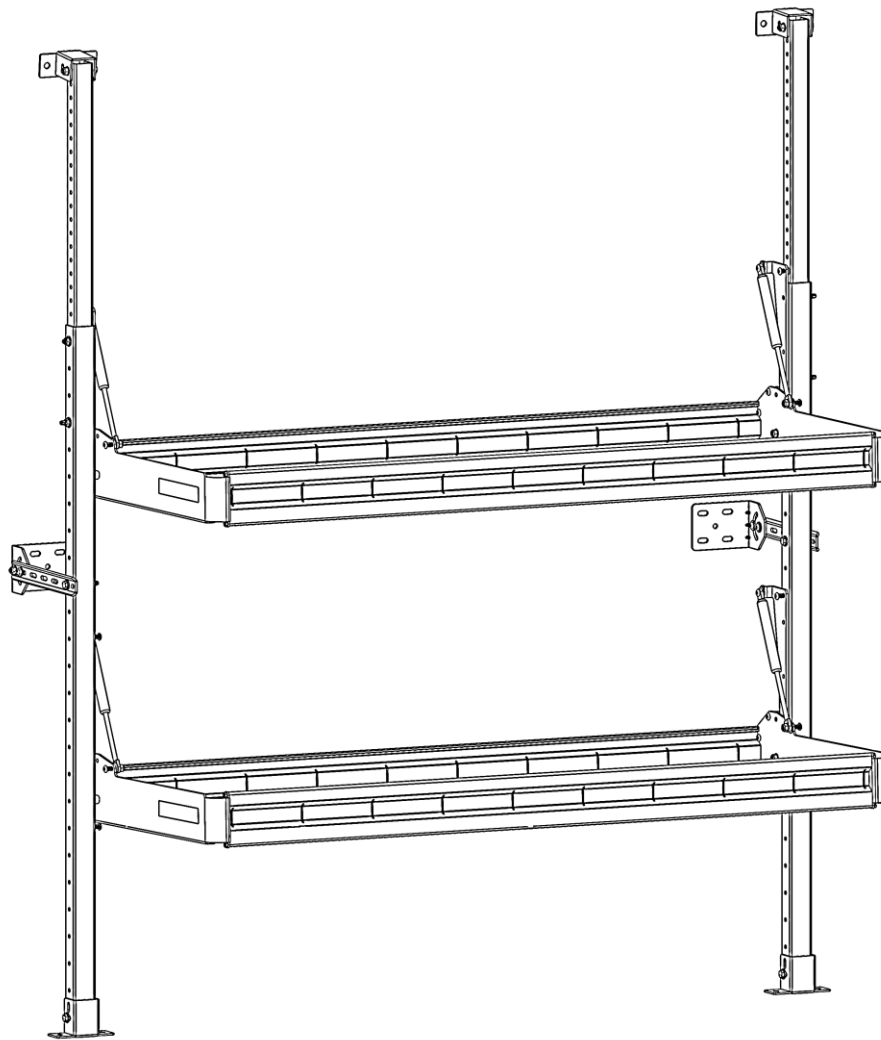

---

Holman  
Rancho Cordova, CA 95742  
800-343-7486

[InstallationSupport@Holman.com](mailto:InstallationSupport@Holman.com)

**PLEASE READ ALL INSTRUCTIONS AND WARNINGS PRIOR TO ASSEMBLING, INSTALLING, AND USING THIS PRODUCT.**

**Warning**



**Always check for wires, fuel tanks and lines, brake lines and other important vehicle functionality items prior to drilling and installing all products.**

**Tools Needed**

7/16" Socket and Wrench	7/16", 9/16" Box Wrench
25/64" Drill Bit	Drill
5/32" Allen Hex Wrench	Plus Nut Installation Tool (P9902)*
Drill Bit Stop Collar	

\* Sold Separately.

**Table of Contents**

Folding Shelf Parts List..... 2

48007 Parts List..... 2

Hardware ..... 3

Step 1 – Attach Upright Feet to Outer Uprights ..... 4

Step 2 – Install Lower Folding Shelf ..... 4

Step 3 – Attach Upright Feet to Inner Uprights ..... 6

Step 4 – Temporarily Attach Inner Uprights to Outer Uprights..... 6

Step 5 – Install Plus Nuts..... 7

Step 6 – Install Upper Folding Shelf ..... 8

Step 7 – Install Upper and Lower Mounts to Vehicle ..... 10

Step 8A – Install Mid-shelf Mounting Brackets (Method 1) ..... 11

Step 8B – Install Mid-shelf Mounting Brackets (Method 2) ..... 12

Step 9 – Verify Shelves Open and Close Smoothly..... 13



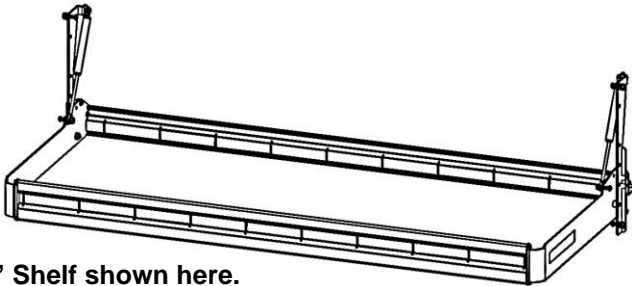

**Before You Begin**

- Read all instructions prior to assembling or installing any Holman product.
- **Always locate your installation locations prior to performing any work.**
- **ENSURE SAFETY WHILE INSTALLING OR DRILLING INTO VEHICLE.**
- **Plus Nut Installation Tool Kit (P9902) is not included and must be purchased separately.**



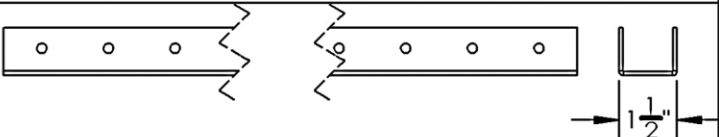

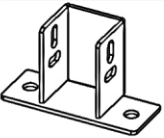
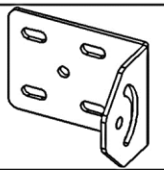

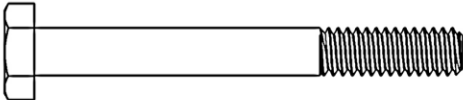
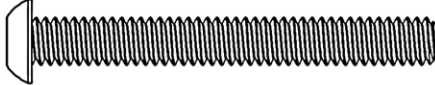

## Folding Shelf Parts List

NO.	ITEM	PART NUMBER	DESCRIPTION	QTY.
1	 <p>*48" Shelf shown here.</p>	48367	36" FOLDING SHELF	2
		48487	48" FOLDING SHELF	
		48607	60" FOLDING SHELF	
3		48007	FOLDABLE SHELF UPRIGHT ASSEMBLY	2

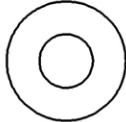
## 48007 Parts List

NO.	ITEM	PART NUMBER	DESCRIPTION	QTY.
1		UFU-00-003	OUTER UPRIGHT	1
2		UFU-00-004	INNER UPRIGHT	1
3		UFU-00-005	UPRIGHT FOOT	2
4		4861-10-001	KNOCK DOWN UPPER MOUNT	1
5		4861-10-002	KNOCK DOWN CONNECTING STRAP	1
6		18-48007	UPRIGHT BOLT KIT	1

### Hardware

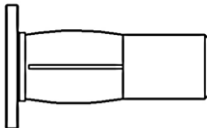
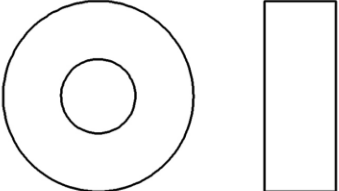
ITEM	HARDWARE TO SCALE	PART NUMBER	DESCRIPTION	QTY.
1			1/4-20 X 2-1/4" PT HEX HEAD	6
2		81057	1/4"-20 X 2-1/8" BUTTON HEAD SCREW	4
3		13800	1/4-20 X 1-1/4" HEX HEAD BOLT	12
4			1/4-20 X 3/4" BUTTON HEAD	8
5		11541082	1/4 FLAT WASHER	26
6		33618	1/4" LOCK WASHER	12
7			1/4"-20 NYLOC JAM NUT	4
8			1/4-20 FLANGED NYLON INSERT NUT	14
9			.25"ID X .5"OD X 1.26"LG NYLON SPACER	4
10			.25"ID X .5"OD X 1.04"LG NYLON SPACER	6
11			.25"ID X .5"OD X .11"L NYLON SPACER	4
12			1/4"-20 PLUS NUT	12
13		11517442	3/8" ID X 1" OD X 3/8" NYLON SPACER	4

### Step 1 – Attach Upright Feet to Outer Uprights

- Using a 1/4"-20 x 2-1/4" hex head bolt, 1/4" washer, one 1/4" x 1.26" nylon spacer, and 1/4" flanged lock nut, attach upright foot to the outer uprights. **Be sure to bolt through the spacer.**
- Repeat for opposite side.

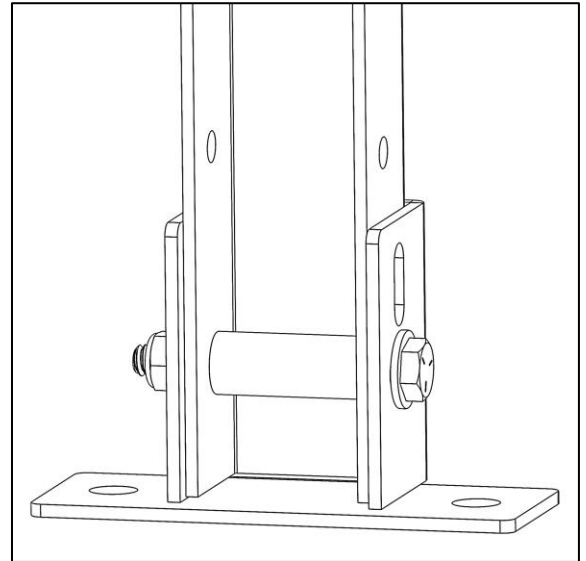
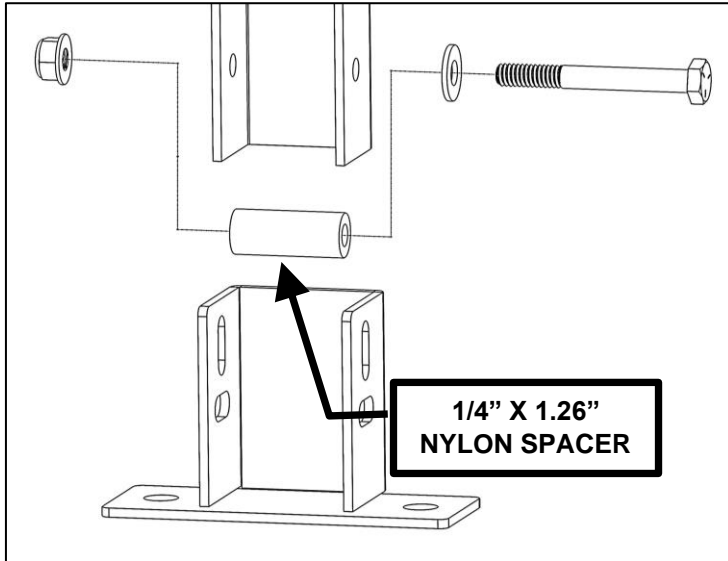

### Step 2 – Install Lower Folding Shelf

- The following is the typical height for the bottom shelf from the bottom of the foot when closed. The minimum distance between an upper shelf and lower shelf is 21".

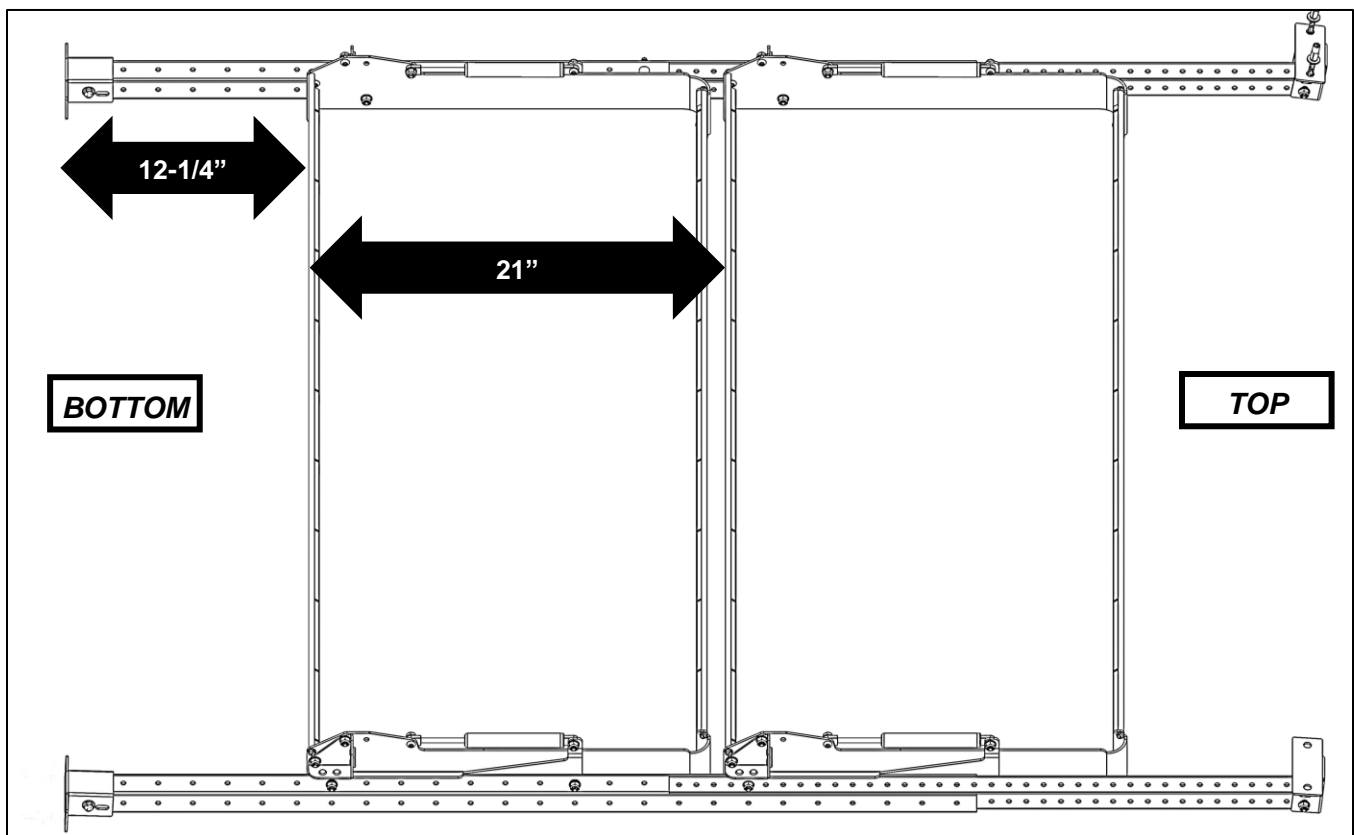

- Remove the 1/4" x 3/4" button head screws, 1/4" x .11" nylon spacers, and 1/4" flanged lock nuts from the shelf side mounting brackets on each side of the pre-assembled folding shelf, as shown.

**NOTE: For the lower shelf, the 1/4" spacers may not be necessary for installation, so set them aside for future use.**

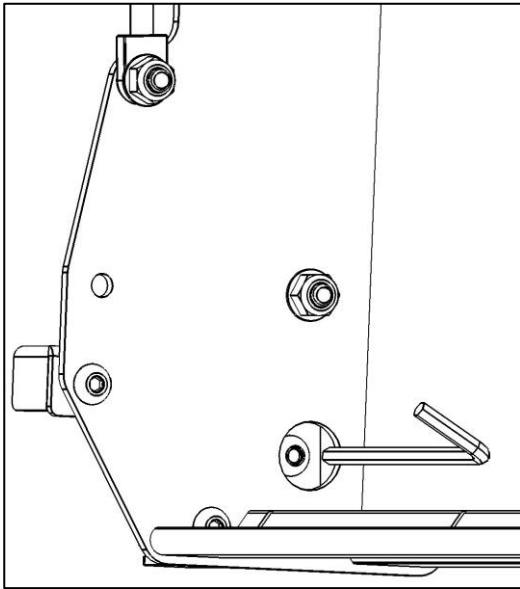
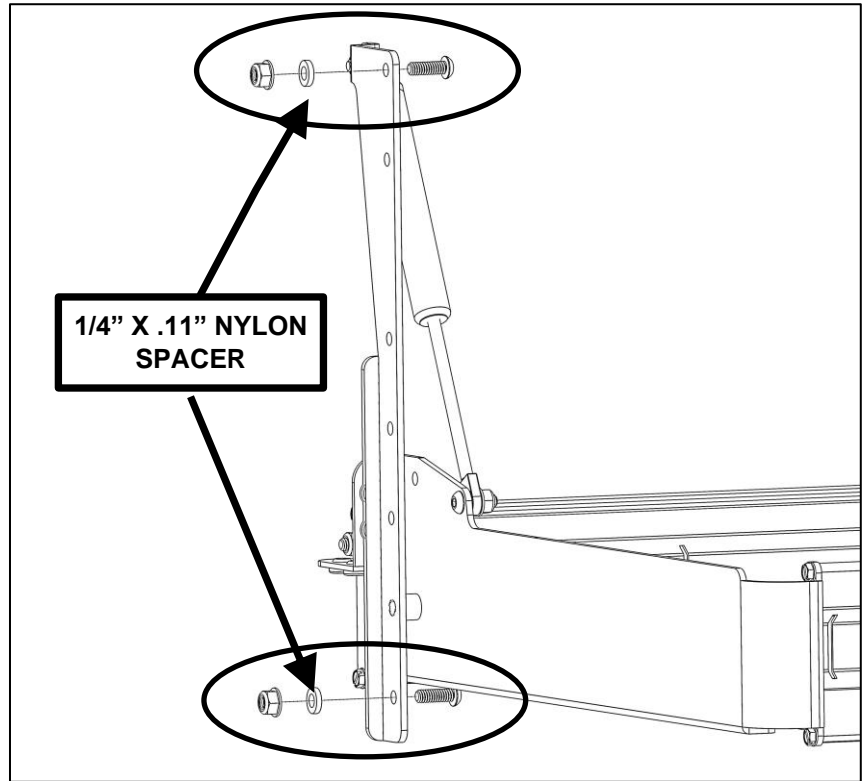

**The lower button head screw head is accessible through the 3/4" hole in the side of the shelf.**

- Using the previously removed 1/4" x 3/4" button head screws and 1/4" flanged lock nuts, attach the lower shelf to the outer uprights.

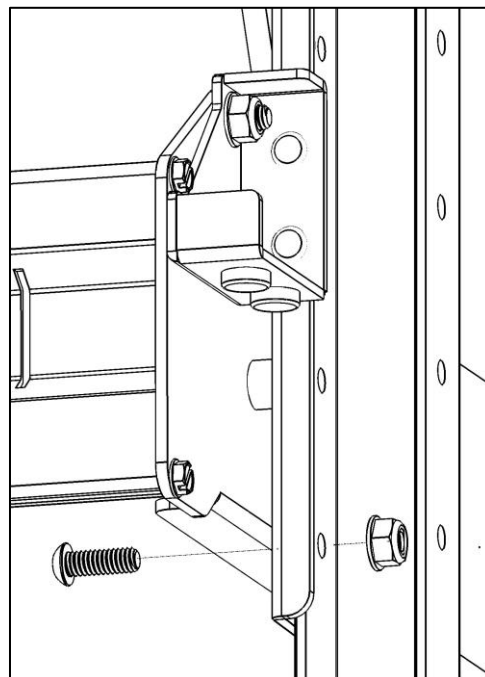
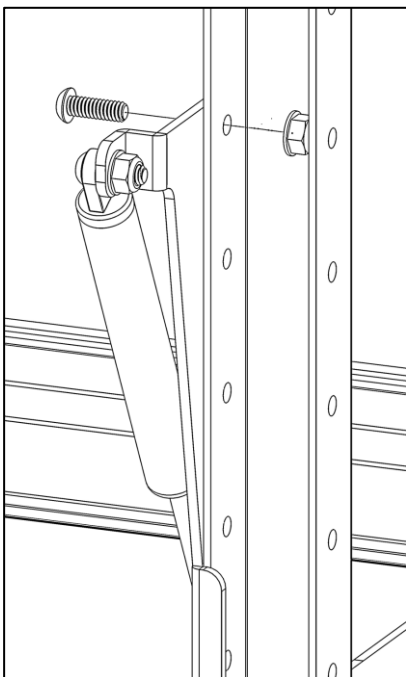

**Again, for ease of tightening, the lower button head screw head is accessible through the 3/4" hole in the side of the shelf.**

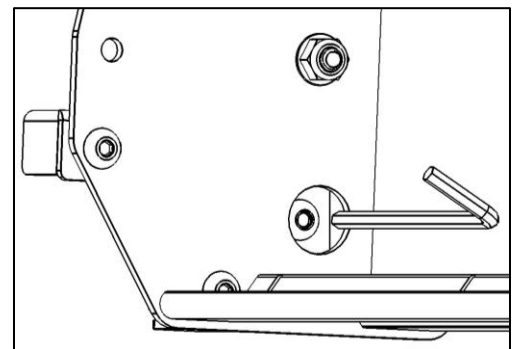

### Step 3 – Attach Upright Feet to Inner Uprights

- Using a 1/4"-20 x 2-1/4" hex head bolt, one 1/4" washer, **one** 1/4" x 1.04" nylon spacers, **two** 1/4" x .11" nylon spacers, and one 1/4" flanged lock nut, bolt the upright foot to an outer upright in the furthest slot from the bottom of the foot.

**NOTE: Be sure the 1/4" x .11" spacers are between the feet and the inner upright.**

- Repeat for opposite side.

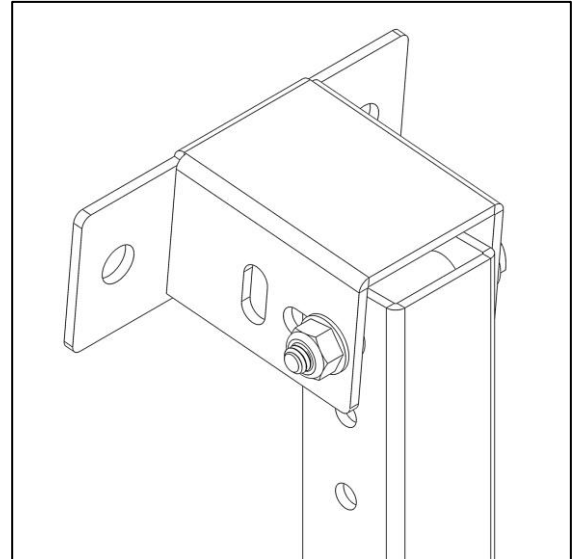
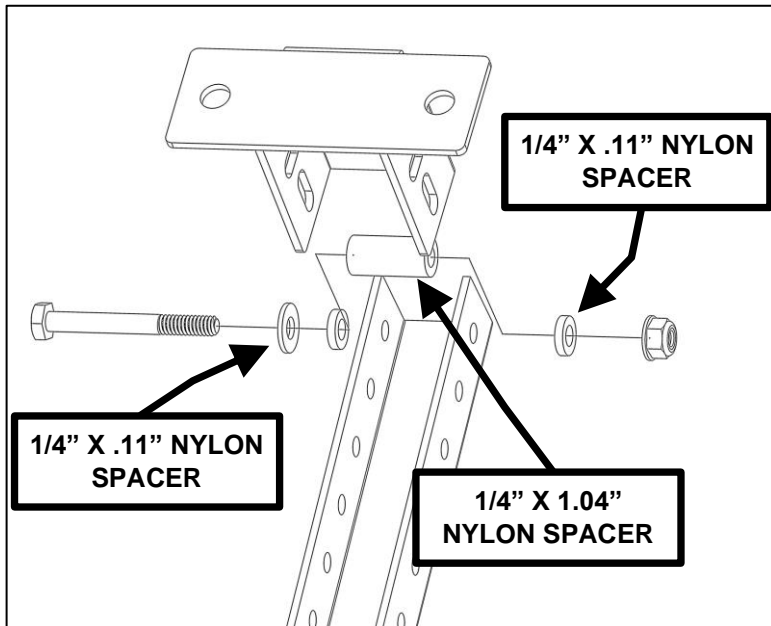

### Step 4 – Temporarily Attach Inner Uprights to Outer Uprights

- Measure the height of upper installation location from the floor.
- Insert inner upright into inside outer upright with the inner upright top foot facing the rear of the shelf.
- Adjust height until upper foot is at the height measured.
- Using a 1/4" x 2-1/8" button head screw and 1/4" flanged lock nut, bolt through outer upright and inner upright.
- DO NOT tighten. Bolts will be removed in next step.
- Repeat for other upright.

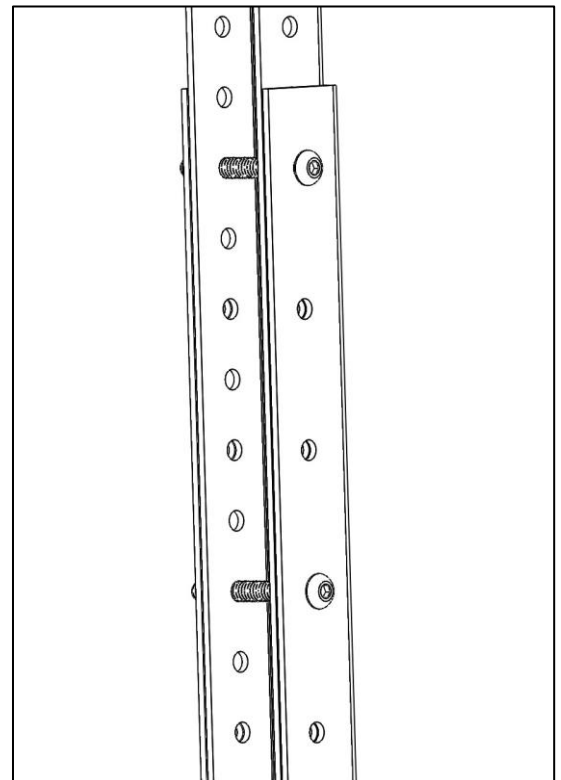

- Holding the assembled shelf upright in the installation position, mark onto the mounting surface the location of the slots in the feet. **Be sure shelving unit is flat and not twisted.**
- Set shelf unit aside.

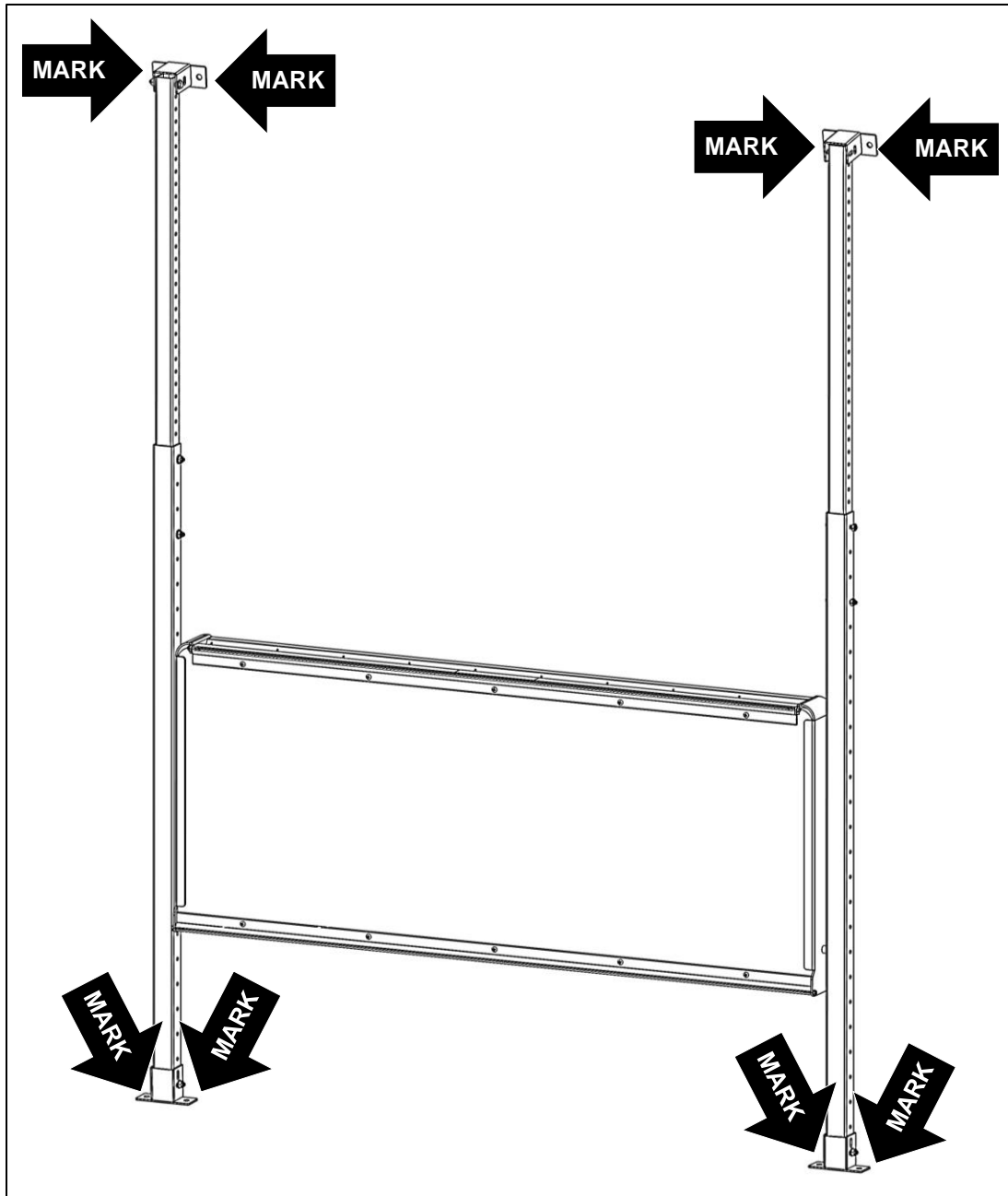

### Step 5 – Install Plus Nuts



**DO NOT drill beyond depth of floor or upper installation surface. Always check for wires, fuel tanks and lines, brake lines and other important vehicle functionality items prior to drilling and installing all products.**

- At each marked location, drill hole using 25/64" drill bit and appropriate sized drill-bit stop collar. If 25/64" drill bit is not available, a 3/8" drill bit can be used, although it may be necessary to tap in the plus nuts.



- Insert 1/4" x 2-1/4" hex head bolt through 1/4" flat washer and plus nut installation tool, and then screw bolt into plus nut. Knurled end of plus nut tool must be directed away from bolt head and contacting plus nut.
- Insert plus nut with tool into hole.
- Using the 9/16" box wrench, hold the plus nut tool stationary and then tighten hex head bolt until plus nut is tightly gripping and does not spin when hex bolt is loosened.
- DO NOT overtighten plus nut.
- Using the 9/16" box wrench, hold the plus nut tool stationary to remove the 1/4" hex head bolt.

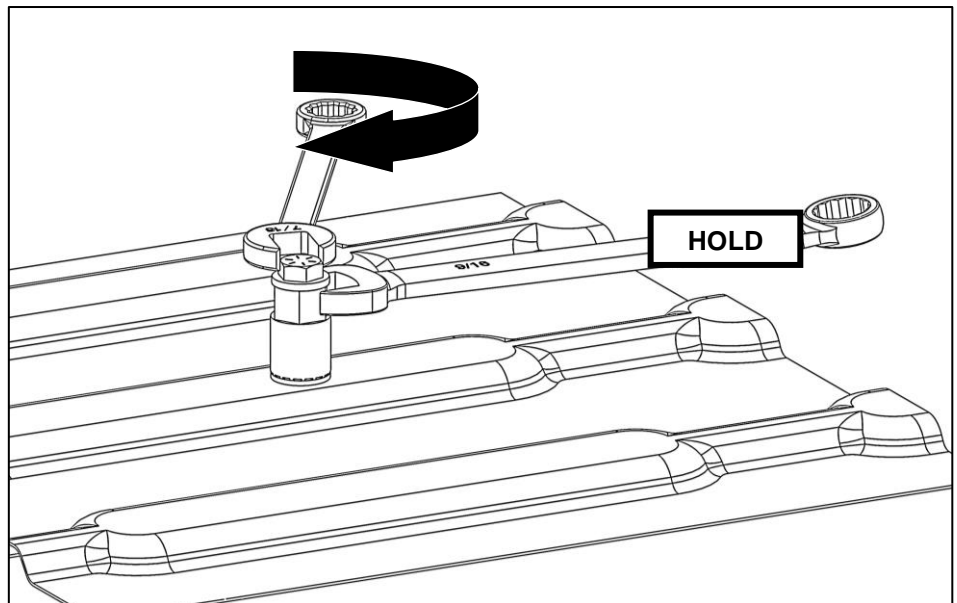
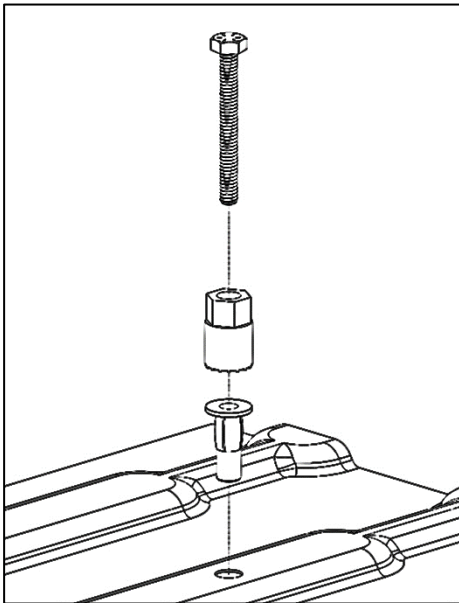

### **Step 6 – Install Upper Folding Shelf**

- Remove the 1/4" x 2-1/8" button head screws and 1/4" flanged lock nuts previously temporarily installed through inner and outer uprights.
- Remove the 1/4" x 3/4" button head screws, 1/4" x .11" nylon spacers, and 1/4" flanged lock nuts from the shelf side mounting brackets on each side of the pre-assembled folding shelf, as shown.
- For the upper shelf, the 1/4" x .11" spacers will be necessary for installation.

**NOTE: Refer to previous images for typical installation height of upper shelf.**

**The lower button head screw head is accessible through the 3/4" hole in the side of the shelf.**

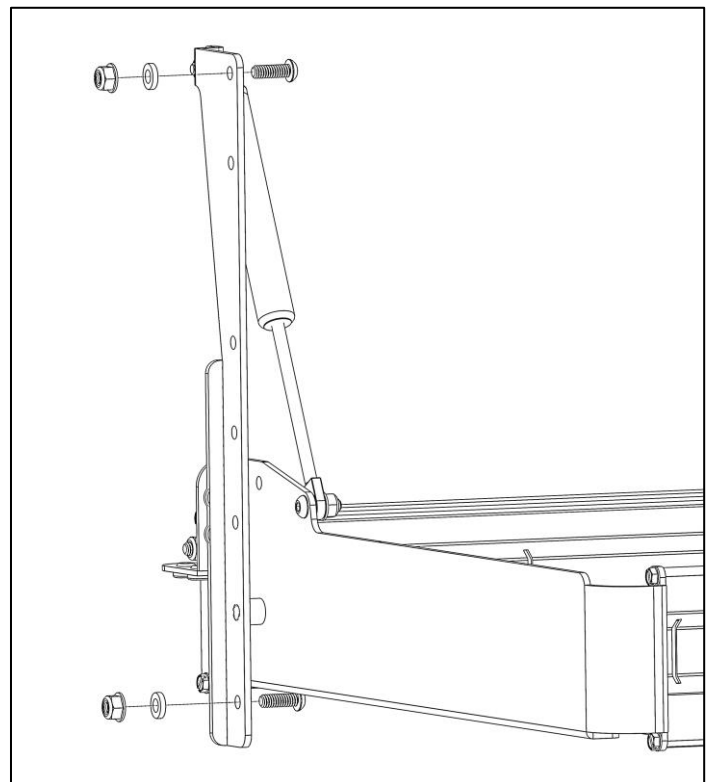

- Using the previously removed 1/4" x 3/4" button head screws, 1/4" x .11" spacers, and 1/4" flanged lock nuts, attach the upper shelf to the outer uprights. **Be sure to insert a 1/4" x .11" spacers between the inner uprights and shelf side mounting brackets.**
- Snug tighten but allow movement.

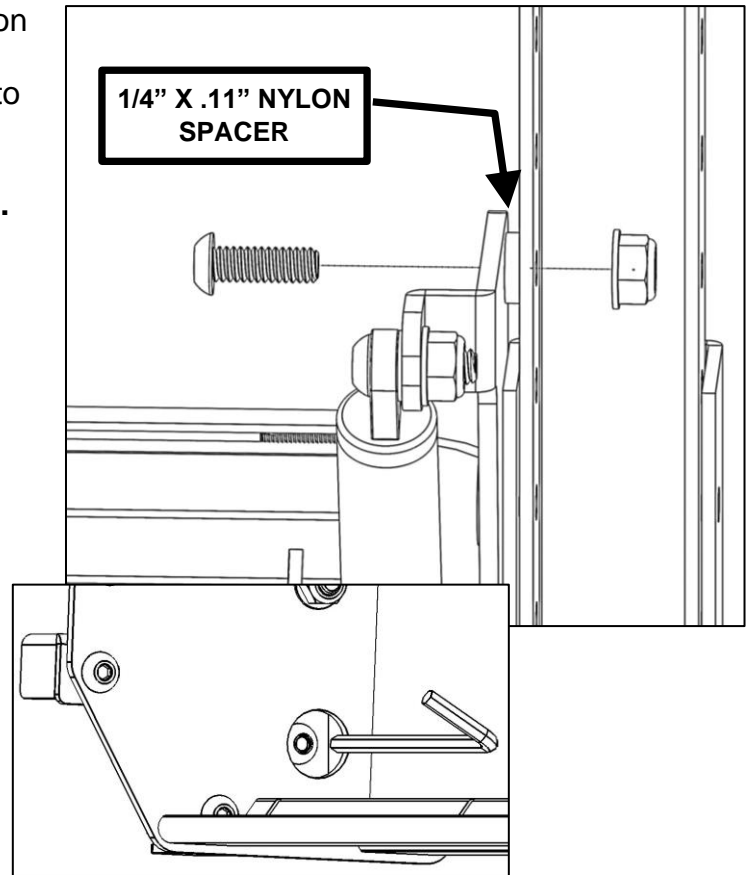
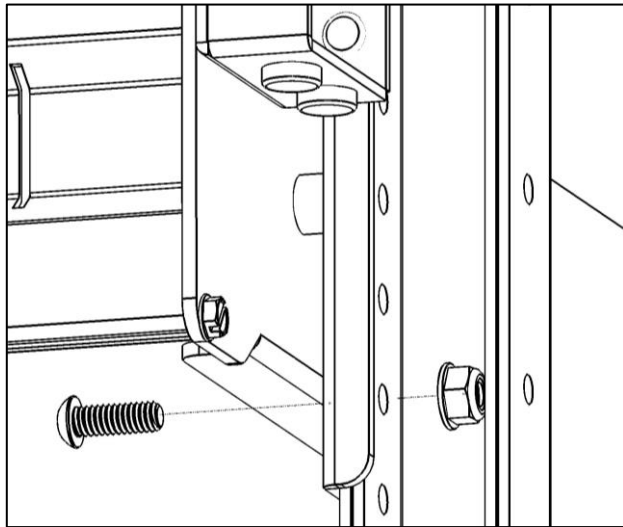

### Assembling Only One Shelving Unit

- Using a 1/4" x 2-1/8" button head screw, 1/4" x 1.26" nylon spacer, two 1/4" washers, and a 1/4" flanged lock nut, bolt through the shelf side mounting bracket, outer upright, and inner upright.
- Snug tighten but allow movement.

**Be sure button head is towards shelf.**

**Be sure to use appropriate nylon spacer to ensure shelf loading stability.**

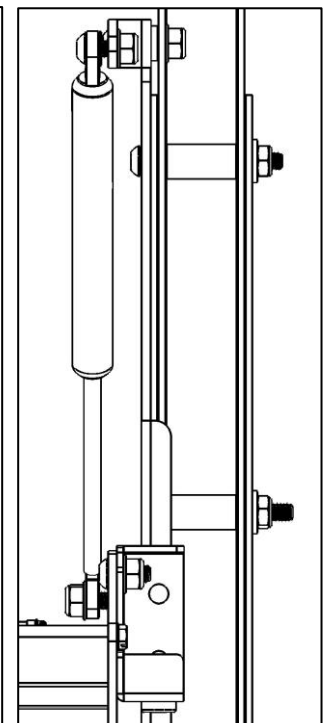
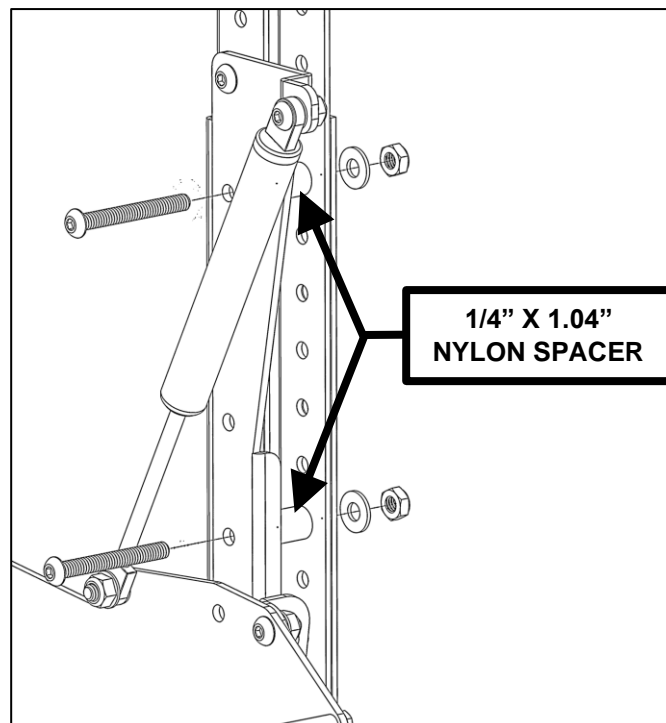

### Connecting More Than One Set of Shelves Together Side-By-Side

- Using a 1/4" x 3/4" button head screw and 1/4" lock nut, secure the shelf to the upright.
- Install the 1/4" x 2-1/8" button head screw, a 1/4" x 1.26" nylon spacer, and 1/4" flanged lock nut in a location that does not interfere with operation of the shelves to provide additional stability.
- Snug tighten but allow movement.
- Repeat steps on opposite side.

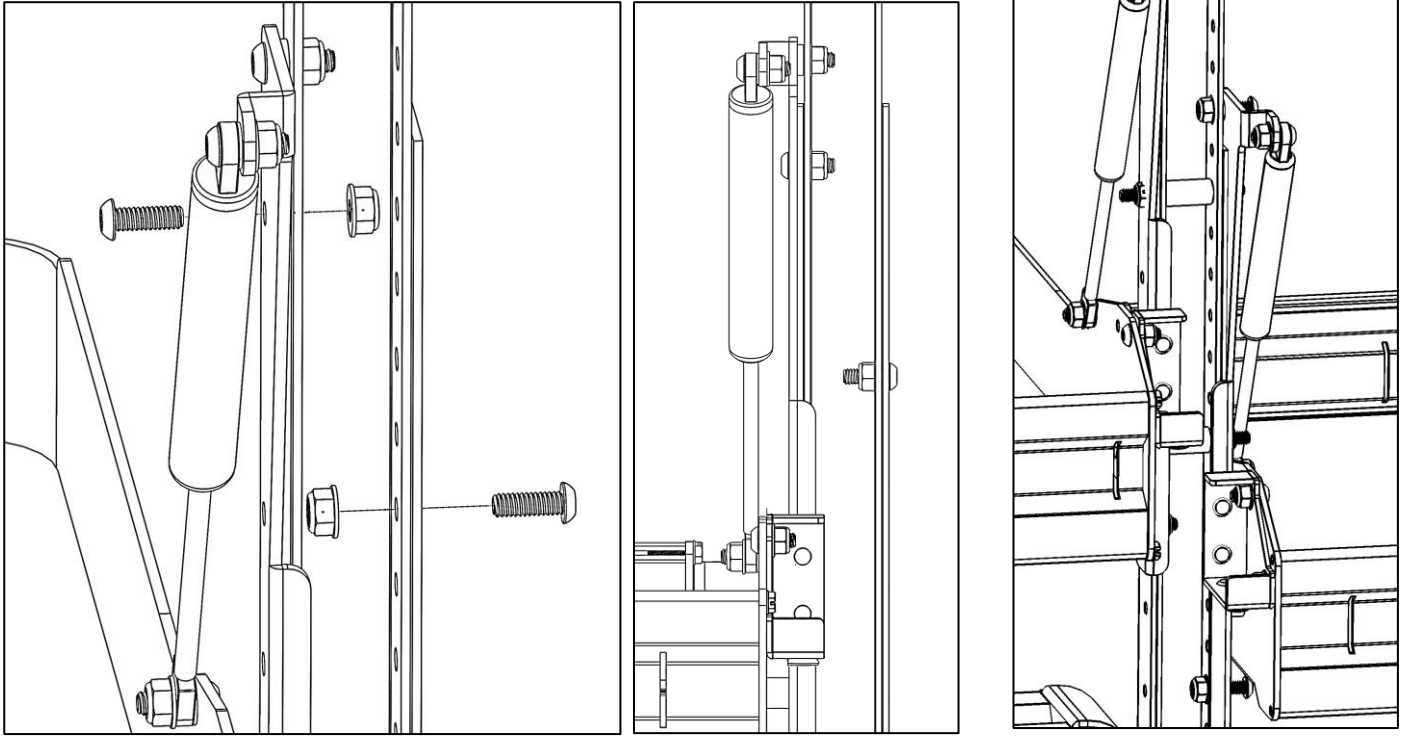

### Step 7 – Install Upper and Lower Mounts to Vehicle

- Using 1-1/4" hex head bolts, 1/4" lock washers, and 1/4" flat washers, bolt shelf to previously installed plus nuts.
- If a gap exists between partition and floor, insert a 3/8" nylon washer under lower mount to bridge gap between as necessary.
- Snug tighten but allow movement.
- Verify shelves open and close smoothly.
- If necessary, loosen and adjust fasteners until shelves operate properly.

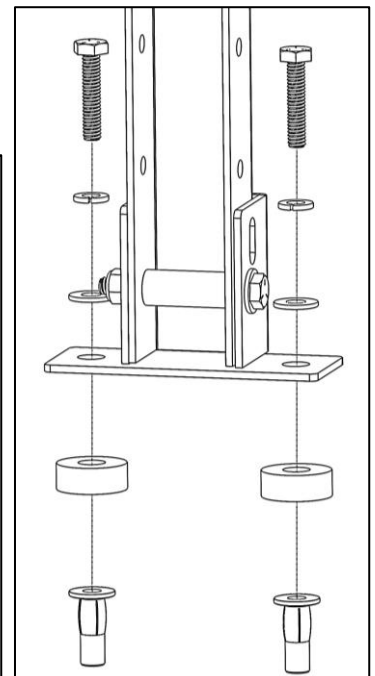
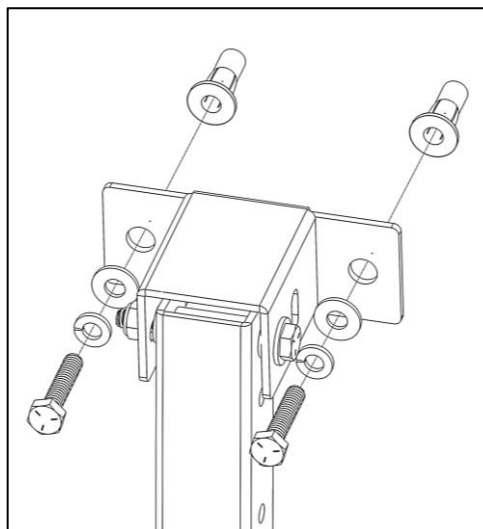

### Step 8A – Install Mid-shelf Mounting Brackets (Method 1)

The best method for installing the mid-shelf mounting brackets depends on the vehicle the shelving unit is installed into. Determine the best method PRIOR to installing the mid-shelf mounts.

- Determine installation location on mid panel of van wall.
- Using one 1/4" x 3/4" button head screw, one 1/4" washer, and one 1/4" lock nut, bolt a knock down upper mount to upright.
- Using one 1/4" x 2-1/4" hex head screw, one 1/4" flat washer, one 1/4" x 1.26" nylon spacer, and one 1/4" flanged lock nut, bolt knock down brackets to upright.
- Snug tighten but allow movement.

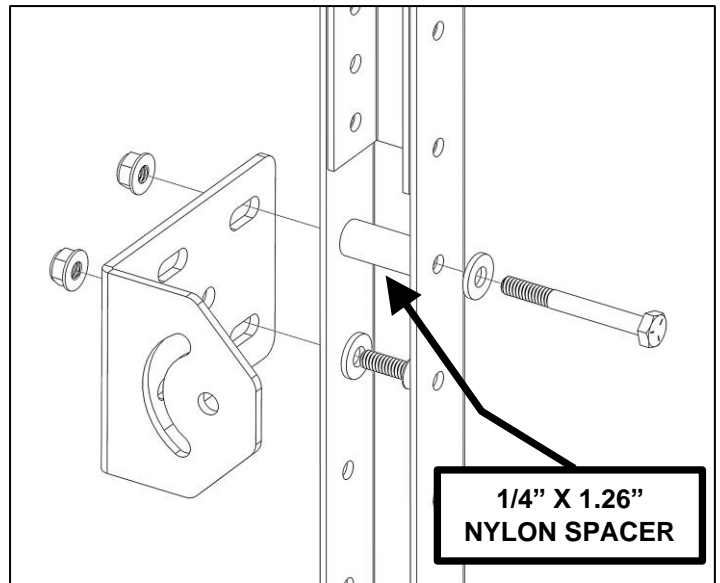

- Mark through the hole in the knock down upper mount, onto the vehicle wall.
- At each marked location, install a plus nut per the plus nut installation instructions in previous step.
- Using a 1-1/4" hex head bolt, a 1/4" lock washers, and a 1/4" flat washers, bolt upper knock down upper mount to previously installed plus nut.
- Snugly tighten but allow movement.
- Repeat steps on opposite end of shelf.

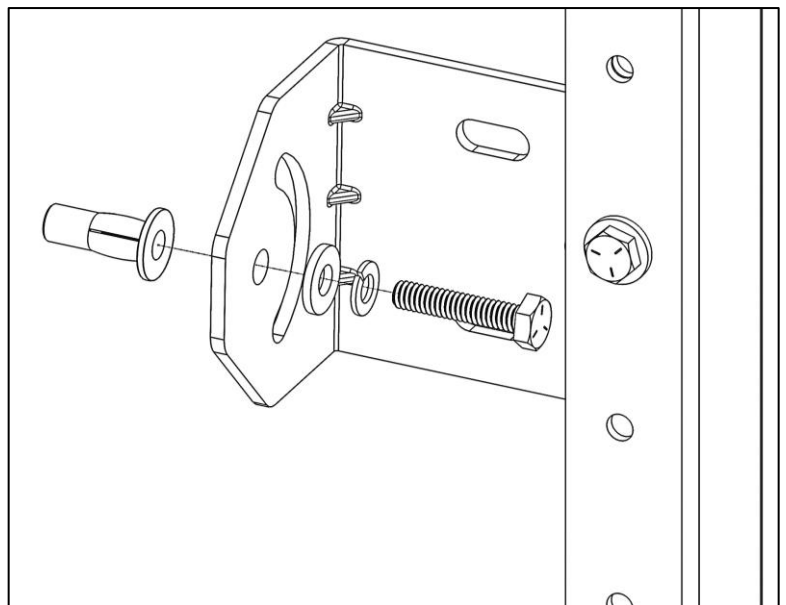
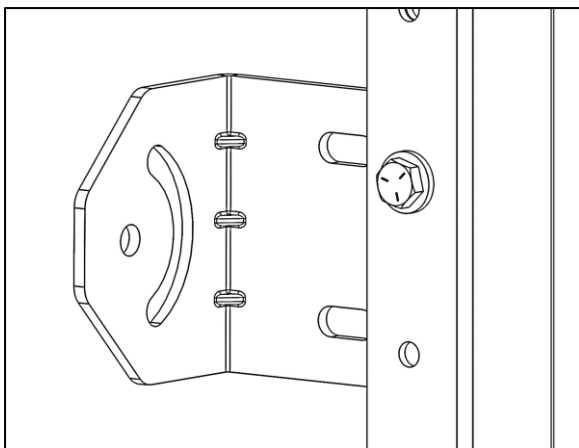

### Step 8B – Install Mid-shelf Mounting Brackets (Method 2)

- Using two 1/4" x 3/4" button head screws, two 1/4" washers, and two 1/4" lock nuts, bolt a knock down upper mount to a knock down connecting strap.
- Snug tighten but allow movement.
- Determine installation location on mid panel of van wall.
- Mark through two of the slots in the knock down upper mount onto wall. The two slots marked in illustration are for example only. Use the holes that best fit the specific installation.
- At each marked location, install a plus nut per the plus nut installation instructions in previous step.
- Using two 1-1/4" hex head bolts, two 1/4" lock washers, and two 1/4" flat washers, bolt upper knock down upper mount to previously installed plus nuts.
- Snugly tighten but allow movement.
- Using one 1/4" x 2-1/4" hex head screw, one 1/4" flat washer, one 1/4" x 1.26" nylon spacer, and one 1/4" flanged lock nut, bolt knock down brackets to upright.
- Repeat steps on opposite side.

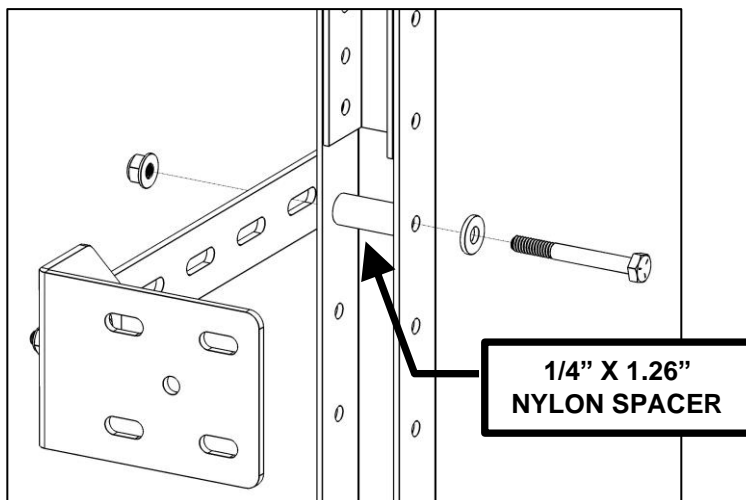
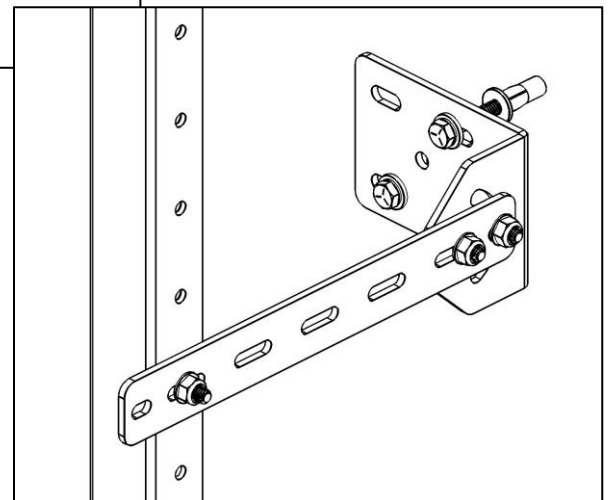
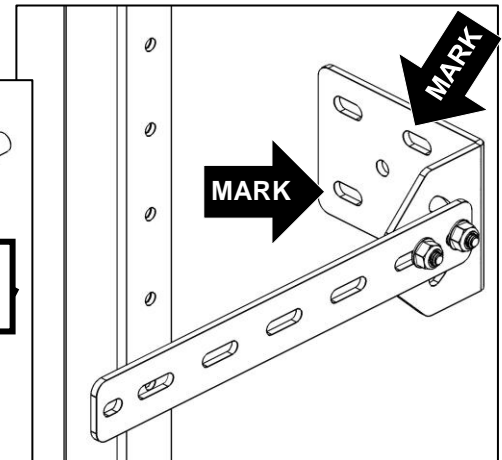
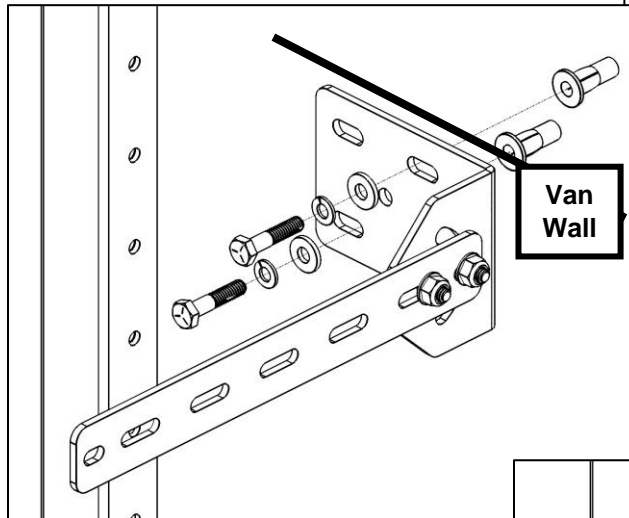
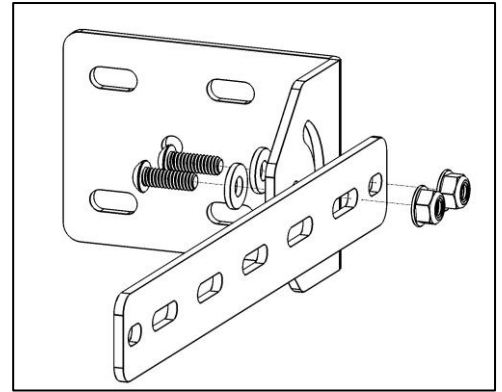

### **Step 9 – Verify Shelves Open and Close Smoothly**

- Loosen and adjust fasteners until shelves operate properly.

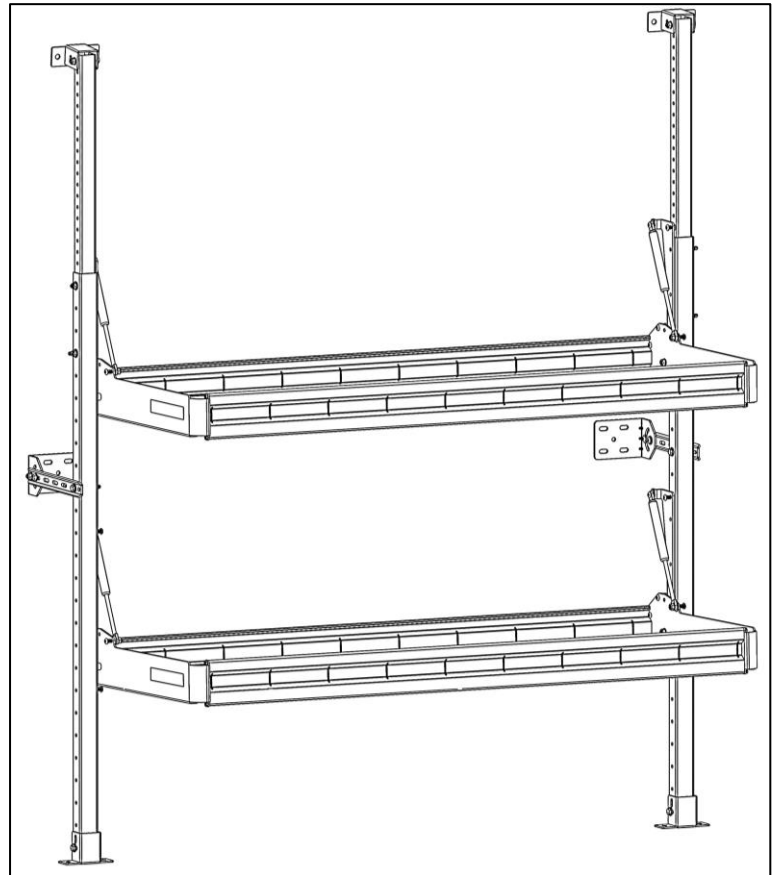
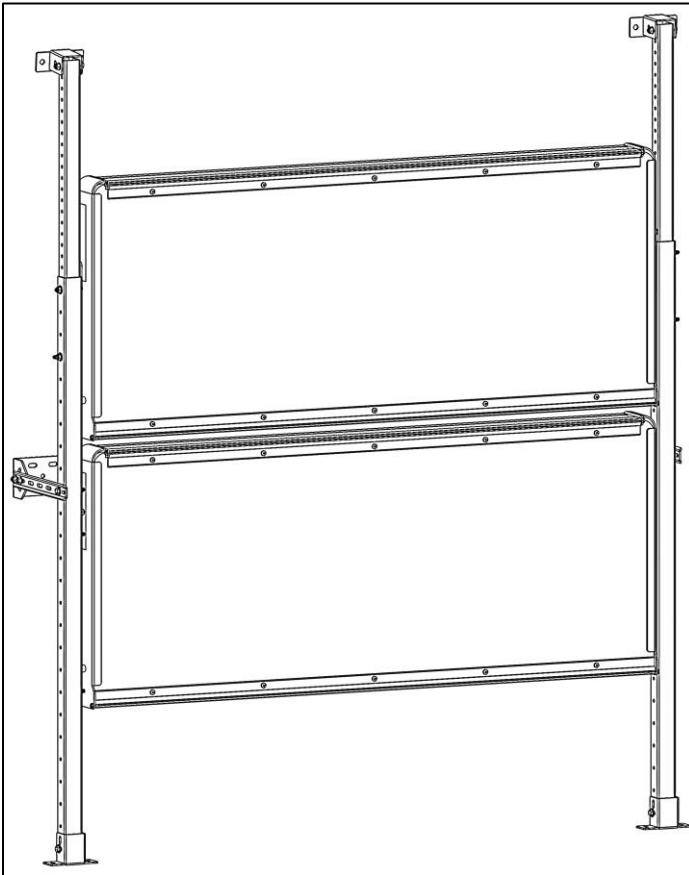

**GO BACK AND TIGHTEN ALL HARDWARE.**

**INSTALLATION AND ASSEMBLY ARE COMPLETE.**